

# MicroCal iTC<sub>200</sub> system

## User Manual



# MAN0560-01-EN-00 August 2014

**Copyright © 2014 Malvern Instruments Ltd.**

Malvern Instruments pursues a policy of continual improvement due to technical development. We therefore reserve the right to deviate from information, descriptions, and specifications in this publication without notice. Malvern Instruments shall not be liable for errors contained herein or for incidental or consequential damages in connection with the furnishing, performance or use of this material. No reproduction or transmission of any part of this publication is allowed without the express written permission of Malvern Instruments Ltd.

Head office:

Malvern Instruments Ltd.  
Groewood Road,  
Malvern,  
Worcestershire, WR14 1XZ  
United Kingdom.

Tel +44 1684 892456

Fax +44 1684 892789

MicroCal, Malvern and the 'hills' logo are registered trademarks in the UK and/or other countries, and are owned by Malvern Instruments Ltd

Windows is a registered trademark of Microsoft Corporation

# Table of Contents

<b>1</b>	<b>Introduction .....</b>	<b>7</b>
1.1	Important user information .....	8
1.2	About this manual .....	10
1.3	Regulatory information .....	11
1.4	Associated documentation .....	12
<b>2</b>	<b>MicroCal iTC<sub>200</sub> .....</b>	<b>13</b>
2.1	Overview of an isothermal titration calorimeter .....	14
2.2	Description of MicroCal iTC <sub>200</sub> .....	18
<b>3</b>	<b>Installation .....</b>	<b>21</b>
3.1	Setting up MicroCal iTC <sub>200</sub> before a run .....	22
3.1.1	<i>Fluid connections</i> .....	23
3.1.2	<i>Bottle preparation</i> .....	27
3.1.3	<i>Hardware connections</i> .....	30
3.2	Installing MicroCal iTC <sub>200</sub> software .....	35
3.2.1	<i>Updating the software</i> .....	36
3.2.2	<i>Complete installation of the software</i> .....	41
3.3	Settings for Windows 7 .....	49
3.3.1	<i>Modify the Origin 7 configuration for Windows 7</i> .....	50
3.3.2	<i>Modify the MicroCal iTC<sub>200</sub> software configuration for Windows 7</i> .....	52
3.3.3	<i>Modify the user account control settings for Windows 7</i> .....	54
<b>4</b>	<b>Control software .....</b>	<b>56</b>
4.1	Overview .....	57
4.2	MicroCal iTC <sub>200</sub> software .....	58
4.2.1	<i>Starting MicroCal iTC<sub>200</sub> software</i> .....	59
4.2.2	<i>MicroCal iTC<sub>200</sub> software interface overview</i> .....	60
4.2.3	<i>MicroCal iTC<sub>200</sub> software control buttons</i> .....	61
4.2.4	<b>Experimental Design</b> tab .....	62
4.2.5	<b>Advanced Experimental Design</b> tab .....	65
4.2.6	<b>Instrument Controls</b> tab .....	72
4.2.7	<b>Real Time Plot</b> tab .....	77
4.2.8	<b>Setup</b> tab .....	78
4.2.9	<i>MicroCal iTC<sub>200</sub> software menus</i> .....	80
4.3	Origin for real-time data display .....	84
<b>5</b>	<b>Performing a run .....</b>	<b>87</b>
5.1	Preparing the samples .....	88
5.1.1	<i>The importance of sample preparation</i> .....	89
5.1.2	<i>Preparing small molecule solutions</i> .....	90
5.1.3	<i>Preparing macromolecule solutions</i> .....	91
5.1.4	<i>Calculating cell concentrations</i> .....	93
5.1.5	<i>Syringe concentration and number of injections</i> .....	97

## Table of Contents

5.1.6	Experimental temperature and control heat determination .....	98
5.1.7	Additional notes .....	99
5.2	Creating a method .....	100
5.3	Cleaning the cell and syringe before performing an experiment .....	103
5.3.1	Cell and syringe wash .....	104
5.3.2	Cell buffer rinse (short) .....	105
5.3.3	Cell water rinse (long) .....	106
5.3.4	Detergent soak and rinse (long) .....	107
5.3.5	Syringe wash (short) .....	108
5.3.6	Syringe wash (long) .....	109
5.3.7	Dry syringe .....	110
5.4	Loading the samples and performing the experiment .....	111
5.4.1	Loading the titration syringe .....	112
5.4.2	Loading the cell .....	114
5.4.3	Performing an experiment .....	115
5.4.4	Procedures after an experiment .....	116
<b>6</b>	<b>Data analysis using Origin .....</b>	<b>118</b>
6.1	Basic ITC data analysis and fitting .....	119
6.1.1	Starting Origin .....	120
6.1.2	Routine ITC data analysis .....	121
6.1.3	Creating a final figure for publication .....	131
6.2	Adjusting baseline and integration range .....	136
6.3	Analyzing multiple runs and subtracting reference .....	143
6.3.1	Opening multiple data files .....	144
6.3.2	Adjusting the molar ratio .....	150
6.3.3	Subtracting reference data .....	152
6.4	ITC data handling .....	161
6.4.1	Reading worksheet values from plotted data .....	162
6.4.2	Copy and paste worksheet data .....	166
6.4.3	Exporting worksheet data .....	168
6.4.4	Importing worksheet data .....	171
6.5	Modifying templates .....	172
6.5.1	Modifying the <b>DeltaH</b> template .....	173
6.5.2	Modifying the <b>RawITC</b> template .....	177
6.5.3	Units notation in Origin .....	179
6.6	Advanced curve fitting .....	181
6.6.1	Nonlinear curve fitting .....	183
6.6.2	Fitting with the <b>two sets of sites</b> model .....	195
6.6.3	Reverse titrations .....	201
6.6.4	The <b>Sequential Binding Sites</b> model .....	206
6.6.5	Binding of multiple ligands to transition metal ions .....	209
6.6.6	Enzyme/substrate/inhibitor assay .....	212
6.6.7	Method 1A: Enzyme assay- substrate only .....	213
6.6.8	Method 1B: Enzyme assay- substrate plus inhibitor .....	222
6.6.9	Method 2A: Enzyme assay- substrate only .....	224

6.6.10	<i>Method 2B: Enzyme assay- substrate plus inhibitor</i> .....	227
6.6.11	<i>Dimer dissociation model</i> .....	229
6.6.12	<i>Competitive ligand binding</i> .....	232
6.6.13	<i>Simulating curves</i> .....	235
6.6.14	<i>Single injection method (SIM)</i> .....	238
6.7	Other useful details .....	248
<b>7</b>	<b>Maintenance</b> .....	<b>253</b>
7.1	Cleaning the cell .....	254
7.2	Refilling the reference cell .....	255
7.3	Washing module .....	256
7.4	Replacing the syringe plunger tip .....	261
7.5	Replacing and cleaning the titration syringe .....	268
<b>8</b>	<b>Troubleshooting</b> .....	<b>278</b>
8.1	Peaks too large .....	279
8.2	Broad peaks .....	281
8.3	Downward stepping baseline .....	283
8.4	Upward stepping baseline .....	284
8.5	Reversed/oscillating peaks .....	285
8.6	Baseline spikes .....	286
8.7	Low baseline .....	288
8.8	Abnormal peaks .....	290
8.9	Unexpected thermodynamic results .....	292
8.10	Washing Module .....	294
<b>9</b>	<b>Reference information</b> .....	<b>296</b>
9.1	How to get help .....	297
9.2	Networking .....	299
9.3	MicroCal iTC <sub>200</sub> ITC methods .....	306
9.4	MicroCal iTC <sub>200</sub> specifications .....	307
9.5	Reagents .....	309
<b>A</b>	<b>Equations used for fitting ITC data</b> .....	<b>310</b>
	<b>Index</b> .....	<b>324</b>



# 1 Introduction

## Introduction

This chapter contains important user information, description of safety notices, reference for regulatory information, intended use of the MicroCal iTC<sub>200</sub> system, a lists of associated documentation.

---

## In this chapter

This chapter contains the following sections:

Section	See page
1.1 Important user information	8
1.2 About this manual	10
1.3 Regulatory information	11
1.4 Associated documentation	12

---

## 1.1 Important user information

### Read this before operating MicroCal iTC<sub>200</sub>



**All users must read the entire *Operating Instructions* before installing, operating, or maintaining the instrument.** Always keep the *Operating Instructions* at hand when operating MicroCal iTC<sub>200</sub>.

Do not operate MicroCal iTC<sub>200</sub> in any other way than described in the user documentation. If you do, you may be exposed to hazards that can lead to personal injury, and you may cause damage to the equipment.

---

### Intended use

MicroCal iTC<sub>200</sub> is an isothermal titration calorimeter designed for biomolecular interaction studies in research applications.

MicroCal iTC<sub>200</sub> is intended for research use only, and shall not be used in any clinical procedures, or for diagnostic purposes.

---

### Prerequisites

In order to operate the system in the way it is intended, the following prerequisites must be fulfilled:

- You should have a general understanding of the use of a personal computer running Microsoft™ Windows™ in the version provided with your product.
  - You should understand the concepts of isothermal titration calorimetry.
  - You must read and understand the Safety Instructions as outlined in *MicroCal iTC<sub>200</sub> Operating Instructions*.
  - The instrument and software must be installed, configured and calibrated as outlined in *MicroCal iTC<sub>200</sub> Operating Instructions* by Malvern Instruments personnel.
-



## Safety notices

This user documentation contains WARNINGS, CAUTIONS and NOTICES concerning the safe use of the product with meanings as defined below.

### Warnings



#### **WARNING**

**WARNING** indicates a hazardous situation which, if not avoided, could result in death or serious injury. It is important not to proceed until all stated conditions are met and clearly understood.

### Cautions



#### **CAUTION**

**CAUTION** indicates a hazardous situation which, if not avoided, could result in minor or moderate injury. It is important not to proceed until all stated conditions are met and clearly understood.

### Notices



#### **NOTICE**

**NOTICE** indicates instructions that must be followed to avoid damage to the product or other equipment.

## Notes and tips

**Note:** *A Note is used to indicate information that is important for trouble-free and optimal use of the product.*

**Tip:** *A tip contains useful information that can improve or optimize your procedures.*

---

## 1.2 About this manual

### Purpose of the user manual

This user manual provides instructions needed to run MicroCal iTC<sub>200</sub> and to analyze isothermal titration calorimetry (ITC) data. This user manual is a complement to *MicroCal iTC<sub>200</sub> Operating Instructions*.

---

### Typographical conventions

Software items are identified in the text by ***bold italic*** text. A colon separates menu levels, thus ***File:Open*** refers to the ***Open*** command in the ***File*** menu.

Hardware items are identified in the text by **bold** text (e.g., **Power** switch).

Text entries that MicroCal iTC<sub>200</sub> software generates or that the user must type are represented by a monotype typeface (e.g., C:\Origin70\Samples).

---

## 1.3 Regulatory information

For regulatory information regarding MicroCal iTC<sub>200</sub>, refer to *MicroCal iTC<sub>200</sub> Operating Instructions*.

## 1.4 Associated documentation

### Introduction

This section lists the user documentation that is delivered with MicroCal iTC<sub>200</sub> and related literature that can be downloaded or ordered from Malvern Instruments.

---

### User documentation

The user documentation for MicroCal iTC<sub>200</sub> consists of:

- *MicroCal iTC<sub>200</sub> Operating Instructions*
  - *MicroCal iTC<sub>200</sub> User Manual* (this manual)
- 

### Related literature

Additional downloadable material can be found at: [www.malvern.com/microcal](http://www.malvern.com/microcal)

---

# 2 MicroCal iTC<sub>200</sub>

## Introduction

This section gives an overview of ITC and the MicroCal iTC<sub>200</sub> system.

---

## In this chapter

This chapter contains the following sections:

Section	See page
2.1 Overview of an isothermal titration calorimeter	14
2.2 Description of MicroCal iTC <sub>200</sub>	18

---

## 2.1 Overview of an isothermal titration calorimeter

### Introduction

Isothermal Titration Calorimeters (ITC) measure the heat change that occurs when two substances interact. Heat is liberated or absorbed as a result of the redistribution of noncovalent bonds, for example, when the interacting molecules go from the free to the bound state.

An ITC mixes the binding partners and monitors these heat changes by measuring the power required to maintain zero temperature difference between the reference and sample cells (see *Main components of an ITC, on page 15*).

The reference cell usually contains water, which has the same heat capacity as most of the sample buffers. The sample cell contains:

- one of the binding partners (often, but not necessarily a macromolecule), and
- a stirring syringe, which holds the other binding partner (often, but not necessarily a ligand).

### Procedure

Typically, the ligand is injected into the sample cell, in 2 to 3  $\mu\text{l}$  aliquots, until its concentration is two- to three-fold greater than that of the sample cell material. Each injection of the ligand results in a heat signature that is first integrated with respect to time and then normalized for concentration. This titration curve is fitted to a binding model to extract the affinity ( $K_D$ ), stoichiometry ( $n$ ) and the enthalpy of interaction ( $\Delta H$ ).

An example experimental curve is depicted below.

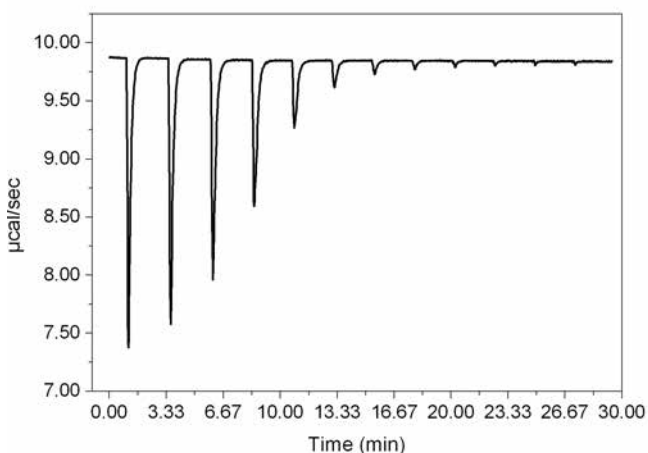

Notice that the first injection results in a larger deflection from the baseline, denoting a larger heat and nearly 100% binding. At the conclusion of the experiment, very little of the injected substance binds, resulting in little or no deflection from baseline (heat).

Also, notice that the value on the y-axis decreases upon binding. In other words, this is the power needed to keep the sample cell at the same temperature as the reference cell.

Heat is given off during the reaction, therefore less power is required to compensate the temperature differences. This is characteristic of an exothermic reaction. In contrast, an endothermic reaction results in spikes rising from the baseline and hence, more power is required to compensate the temperature differences.

## Main components of an ITC

The main components of an ITC system are illustrated below:

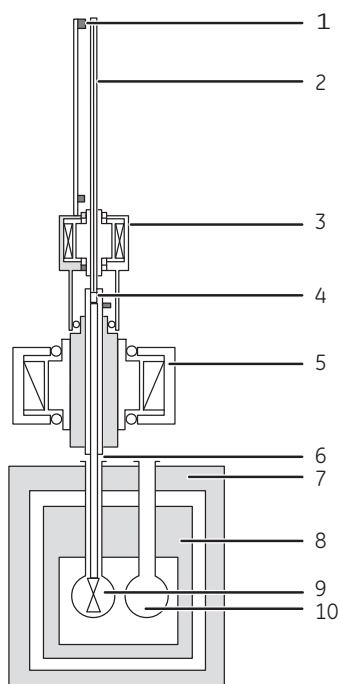

Part	Description
1	Sensor
2	Lead screw

## 2 MicroCal iTC<sub>200</sub>

### 2.1 Overview of an isothermal titration calorimeter

Part	Description
3	Injector
4	Plunger
5	Stirring syringe
6	Syringe
7	Outer shield
8	Inner shield
9	Sample cell
10	Reference cell

### Raw data

The temperature difference between the sample cell and the reference cell is converted to power and directly read out as raw data. An example of this is depicted below. Each spike, followed by a return to the baseline, is an injection.

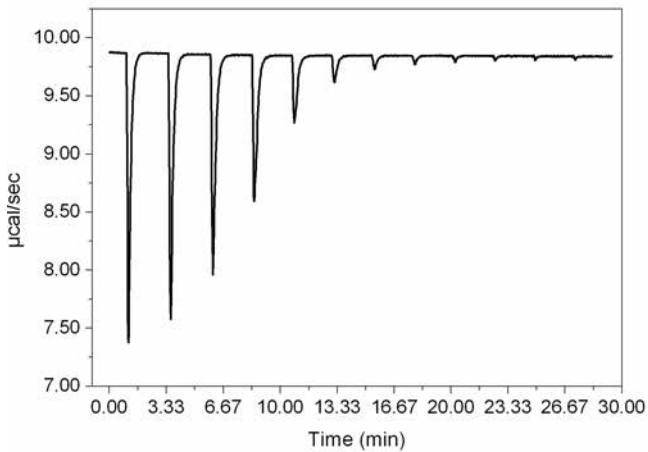



## Injection heat

The individual injection heats are calculated by integrating the raw data (power) from each injection over time. The figure below depicts each individual injection heat, normalized by the amount of titrant injected, as a function of the molar ratio of titrant/cell material in the sample cell. The fitted curve of a 1:1 binding model is overlaid in red. A general illustration of how the thermodynamic parameters  $n$ ,  $K_D$ , and  $\Delta H$  are related to the titration curve is also overlaid.

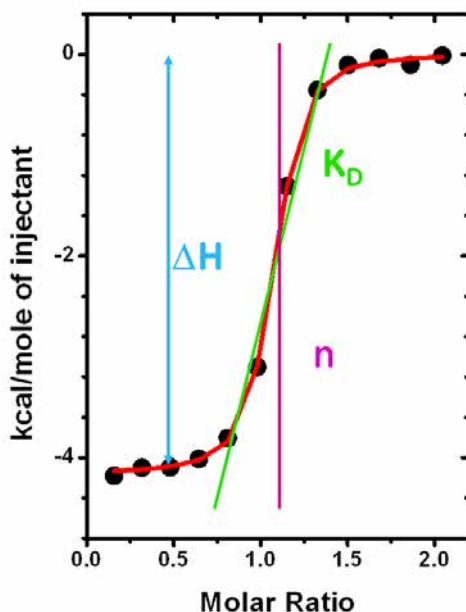

In the case of this simple 1:1 binding experiment, the enthalpy is directly measured/fitted as the heat of 100% binding. The stoichiometry is intuitively denoted by the midpoint of the titration, between 100% binding and 0% binding. The steepness of the rise to saturation is related to binding affinity. For any given system, the steepness of this region is also directly related to the sample concentration.

Data analysis will be explained in more detail in *Chapter 6 Data analysis using Origin, on page 118*.

## 2.2 Description of MicroCal iTC<sub>200</sub>

### Introduction

MicroCal iTC<sub>200</sub> provides detailed insight into binding energetics.

The system has a 200  $\mu\text{l}$  sample cell and provides direct measurement of the heat absorbed or evolved as a result of mixing precise amounts of reactants. The sample and reference cells are made from Hastelloy™, a highly inert material.

Data analysis is performed using Origin™ software, wherein the user obtains the stoichiometry ( $n$ ), dissociation constant ( $K_D$ ), and enthalpy ( $\Delta H$ ) of the interaction. The Origin software can also be used to fit more complicated models.

---

## Primary components of MicroCal iTC<sub>200</sub>

The primary components of MicroCal iTC<sub>200</sub> are illustrated below.



Part	Description
1	Reagent bottles
2	Loading syringe
3	Cleaning module
4	Washing module
5	Fill port adapter (FPA)
6	Pipette
7	Wash/load station
8	Titrant loading station
9	Calorimeter

## Connections at the rear of the MicroCal iTC<sub>200</sub> cell unit

The illustration below shows the rear of the MicroCal iTC<sub>200</sub> cell unit.

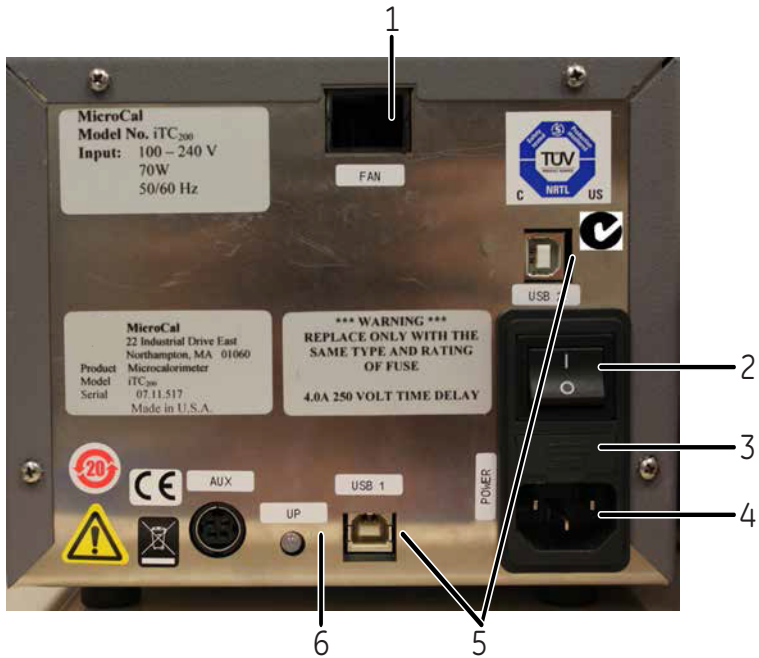

Part	Function
1	Fan
2	Main power switch
3	Power fuses
4	IEC 320 inlet power receptacle
5	USB connectors
6	μP activity indicator

# 3 Installation

## Introduction

This chapter describes how to set up MicroCal iTC<sub>200</sub> before a run, the installation of MicroCal iTC<sub>200</sub> software and settings for Windows 7.

Information about Networking, see *Section 9.2 Networking, on page 299*.

---

## In this chapter

This chapter contains the following sections:

Section	See page
3.1 Setting up MicroCal iTC <sub>200</sub> before a run	22
3.2 Installing MicroCal iTC <sub>200</sub> software	35
3.3 Settings for Windows 7	49

---

## 3 Installation

### 3.1 Setting up MicroCal iTC<sub>200</sub> before a run

# 3.1 Setting up MicroCal iTC<sub>200</sub> before a run

## Introduction

This chapter describes the preparations and how to set up MicroCal iTC<sub>200</sub> before a run.

---

## In this chapter

This chapter contains the following sections:

Section	See page
3.1.1 Fluid connections	23
3.1.2 Bottle preparation	27
3.1.3 Hardware connections	30

---

## 3.1.1 Fluid connections

### Fluid connections on the MicroCal iTC<sub>200</sub> instrument

Fluid connections for the MicroCal iTC<sub>200</sub> system are provided. To mount the connections, follow the steps described below:

Step	Action
------	--------

- |   |  |
|---|--|
| 1 | Connect the line from the top of the cell cleaning module to port <b>C3</b> on the left side of the washing module.                |
| 2 | Connect the line that originates at the side of the cell cleaning module to port <b>C4</b> on the left side of the washing module. |

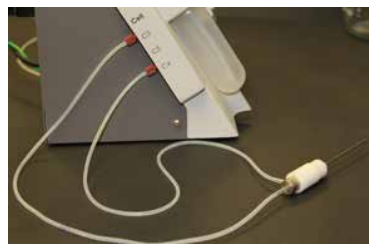

- |   |  |
|---|--|
| 3 | Connect the waste line to port <b>C5</b> on the left side of the washing module. |
|---|--|



- |   |   |
|---|---|
| 4 | Connect Syringe Needle Cleaning Tube (ASY020512) from the port on the Wash Dry Station on the right side of cell unit (left image below) to port <b>C2</b> on the right side of the washing module (right image below). |
|---|---|

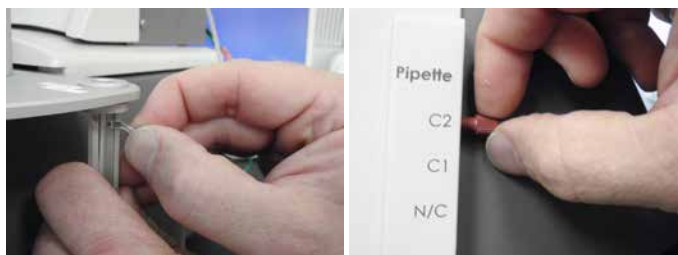

### 3 Installation

#### 3.1 Setting up MicroCal iTC<sub>200</sub> before a run

##### 3.1.1 Fluid connections

Step	Action
5	Connect the red ferrule (see arrow) of the fill port adapter (FPA) (ASY020506) to port <b>C1</b> on the right side of the instrument.

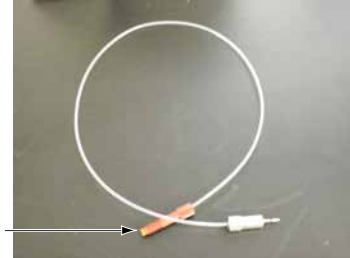

6	Screw the FPA into the top right block in the rear of the washing module, and turn it down until it is flush with the top of the housing.
---	---





## Connect tubing from the bottles

To connect the tubing from the bottles to the bottle adapter, follow the steps described below:

Step	Action
1	<ul style="list-style-type: none"><li>• Connect the blue bottle to the water inlet port</li><li>• Connect the red bottle to the methanol inlet port</li><li>• Connect the white bottle to the buffer inlet port</li></ul>

**Note:**

*Do not over-tighten.*



- 2 Remove the securing nut from the top of the waste bottle and slide the open end of the waste tubing through it.
- 3 Slide the ferrule over the tubing with the cone end facing towards the securing nut, see the illustration below.

**Note:**

*The opposite end of the waste tube should be installed in the C5 port on the washing module. See the step-action table in Fluid connections on the MicroCal iTC<sub>200</sub> instrument, on page 23 above.*



### 3 Installation

#### 3.1 Setting up MicroCal iTC<sub>200</sub> before a run

##### 3.1.1 Fluid connections

Step	Action
------	--------

- |   |  |
|---|--|
| 4 | Insert the waste line (connected to the C5 port on the washing module) into the grey (waste) bottle and tighten the securing nut until it is finger tight. |
|---|--|



- |   |   |
|---|---|
| 5 | Bundle the three fluid lines from the adapter and position them so they will not interfere with your experiments. |
|---|---|



## 3.1.2 Bottle preparation

Before running an experiment, you may need to perform one or all of the following tasks:

- Bottle preparation
- Filling bottles
- Priming tubing
- Emptying the waste bottle

### Bottle preparation

Use this procedure to prepare the bottles before using the washing module. There are three bottles that you must maintain:

- Water: bottle with blue top
- Methanol: bottle with red top
- Buffer: bottle with white top



### Filling bottles

Although the bottles do not have to be full before you begin a procedure, you should make sure that there is sufficient volume in each bottle to perform the required procedure.

To fill the bottles, follow the steps described below:

Step	Action
------	--------

- |   |   |
|---|---|
| 1 | Verify that the system is in an idle state. |
|---|---|

## 3 Installation

### 3.1 Setting up MicroCal iTC<sub>200</sub> before a run

#### 3.1.2 Bottle preparation

Step	Action
------	--------

- |   |  |
|---|--|
| 2 | Unscrew the plastic cap of the bottle by turning it counter-clockwise. |
|---|--|



- |   |  |
|---|--|
| 3 | Fill bottle using standard lab procedures.       |
| 4 | Tighten the cap by turning clockwise until snug. |

## Priming tubing

Use this procedure to prime the tubing from the bottles to the washing module to make sure that the full volume is delivered. This procedure is required only if the tubes leading from the bottles to the washing module have been drained of fluid and contain air.

Step	Action
------	--------

- |   |   |
|---|---|
| 1 | Make sure all bottles have sufficient volume and all fluid lines are connected. |
| 2 | Click <b>Cell Buffer Rinse (Short)</b> on the <b>Instrument Controls</b> tab.   |
| 3 | Click <b>Syringe Wash (Long)</b> on the <b>Instrument Controls</b> tab.         |

After tubings have been primed (visibly clear of air), the system uses the majority of the remaining procedure time to dry the syringe. This occurs with approximately eight minutes remaining in the procedure. You can let the procedure finish or click **Cancel** at this time.

## Emptying the waste bottle

Use this procedure to empty the waste bottle.

Step	Action
------	--------

- |   |   |
|---|---|
| 1 | Verify that the system is in an idle state. |
|---|---|

Step	Action
2	Unscrew the grey cap of waste bottle by turning the lid counter-clockwise.
3	Empty the waste according to your laboratory waste handling procedures.
4	Reattach the cap by turning it clockwise until it is snug.

### 3 Installation

#### 3.1 Setting up MicroCal iTC<sub>200</sub> before a run

##### 3.1.3 Hardware connections

## 3.1.3 Hardware connections

### Introduction

The washing module, the MicroCal iTC<sub>200</sub> controller PC and the MicroCal iTC<sub>200</sub> cell unit are connected through a standard USB 4-port hub.

The following hardware is required to connect the three parts of MicroCal iTC<sub>200</sub>:

- One USB 2.0 4-port hub
- One type A-B (mini) USB connector
- Two type A-B (standard) USB connectors

Part	Description
	USB 2.0 4-port hub
	USB Connector type A
	USB Connector type B (mini)
	USB Connector type B (standard)

## Mounting the hardware connections

To mount the hardware connections, follow the steps described below:

Step	Action
------	--------

- |   |  |
|---|--|
| 1 | Identify the only cable with the <b>USB type B (mini) cable</b> end.<br>Connect the <b>type B (mini) cable</b> end to the <b>USB hub</b> . |
|---|--|



Connect the **USB type A** end of that cable to the labeled **Controller PC USB port**.

- |   |   |
|---|---|
| 2 | Connect the <b>USB type A</b> ends of two <b>USB cables</b> to the hub. |
|---|---|



- |   |   |
|---|---|
| 3 | Connect the <b>USB type B</b> ends to the <b>USB 1</b> and <b>USB 2</b> connectors on the rear of the MicroCal iTC <sub>200</sub> cell unit. For illustration, see <i>Connections at the rear of the MicroCal iTC<sub>200</sub> cell unit, on page 20</i> . |
| 4 | Place the washing module on top of the MicroCal iTC <sub>200</sub> cell unit.<br>When properly positioned, the feet on the washing module will fit into the depressions on the top of the cell unit to keep it from sliding off.                            |
| 5 | Connect the USB type A end from the washing module to the hub.  |

### 3 Installation

#### 3.1 Setting up MicroCal iTC<sub>200</sub> before a run

##### 3.1.3 Hardware connections

Step	Action
------	--------

- |   |  |
|---|--|
| 6 | Connect the green grounding strap wire between the washing module and the MicroCal iTC <sub>200</sub> cell unit. |
|---|--|

The illustration below shows the rear of the washing module and the MicroCal iTC<sub>200</sub> cell unit.





## Electrical connections for the cell unit

To connect the cell unit to the electrical supply, follow the steps described below:

Step	Action
1	Connect the power cord to the IEC 320 inlet power receptacle on the back of the cell unit. (For illustration, see <i>Connections at the rear of the MicroCal iTC<sub>200</sub> cell unit</i> , on page 20.)
2	Connect the power plug to a main power supply receptacle with a 3-wire protective Earth ground and a Ground Fault Circuit Interrupter (GFCI).



### WARNING

Always plug the instrument into a Ground Fault Circuit Interrupter (GFCI).

## Electrical Connections for the Washing Module

The illustration below shows the washing module power supply unit.



To connect the washing module to the electrical supply, follow the steps described below:

Step	Action
1	Connect the power cord from the power supply to the power receptacle on the rear of the washing module.
2	Connect the power supply to a main power supply receptacle with a 3-wire protective Earth ground and a Ground Fault Circuit Interrupter (GFCI).

## 3 Installation

### 3.1 Setting up MicroCal iTC<sub>200</sub> before a run

#### 3.1.3 Hardware connections



#### **WARNING**

To enhance safety always plug the instrument into a Ground Fault Circuit Interrupter (GFCI).

## 3.2 Installing MicroCal iTC<sub>200</sub> software

### Introduction

If a previous version of software is installed on the controller, then follow the software update instructions described in *Section 3.2.1 Updating the software, on page 36* otherwise follow the instructions for a full installation in *Section 3.2.2 Complete installation of the software, on page 41*.

---

### In this section

This section contains the following topics:

Section	See page
3.2.1 Updating the software	36
3.2.2 Complete installation of the software	41

---

### 3 Installation

#### 3.2 Installing MicroCal iTC<sub>200</sub> software

##### 3.2.1 Updating the software

### 3.2.1 Updating the software

**Note:** *Installation of the control software requires administrative privileges.*

#### Removing previous versions of the OriginAddOn application

To remove previous versions of the OriginAddOn application, follow the steps described below:

Step	Action
1	Navigate to <b>Start:Control Panel</b> .
2	Select <b>Add/Remove Programs</b> (Windows XP) or <b>Programs and Features</b> (Windows 7).
3	Select <b>OriginAddOn</b> and click <b>Remove/Uninstall</b> .

#### Updating the control software

The control software CD contains the following applications:

- MicroCal iTC<sub>200</sub> software
- USB driver for injector
- USB driver for data acquisition
- InitDT service
- .Net runtime

To update the control software, follow the steps described below:

Step	Action
------	--------

- |   |   |
|---|---|
| 1 | Insert the CD into the CD-ROM drive of the PC.<br>The CD runs automatically and the <b>MicroCal Setup</b> window appears. |
|---|---|

**Note:**

*If the CD does not start automatically, run **iTC200Setup.exe** from the CD.*



- |   |   |
|---|---|
| 2 | Click on the <b>iTC200 Software Update</b> button for the installation to start automatically.      |
| 3 | Follow the on-screen instructions and click <b>Finish</b> when the installation is complete.        |
| 4 | Select the option to restart the computer. Shortcut icons are created on the desktop automatically. |



- |   |   |
|---|---|
| 5 | Exit the main menu, remove the CD and keep it in a safe place after the applications has been installed as described. |
|---|---|

### 3 Installation

#### 3.2 Installing MicroCal iTC<sub>200</sub> software

##### 3.2.1 Updating the software

## Updating analysis software

The MicroCal iTC<sub>200</sub> Analysis Software and License CD (formerly called the Origin analysis software installation CD) contains the following applications:

- Origin 7.0 (for scientific graphing and analysis)
- Origin Service Pack 4
- MicroCal AddOn for Origin 7.0 (for data analysis specific to MicroCal iTC<sub>200</sub> applications)

To update the Origin Data Analysis Add-On follow the steps described below:

Step	Action
------	--------

- |   |   |
|---|---|
| 1 | Insert the CD into the CD-ROM drive of the PC.<br>The CD runs automatically and the <b>MicroCal's Setup</b> window appears. |
|---|---|

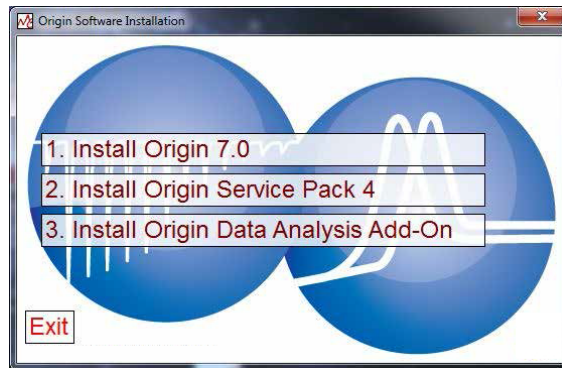

- |   |  |
|---|--|
| 2 | Install only the Origin Data Analysis Add-On.                |
| 3 | Click the <b>Install Origin Data Analysis Add-On</b> button. |

**Note:**

*Make sure that the **Yes, I wish to install an Add-On disk now** option is checked in the pop-up window.*

- |   |                     |
|---|---------------------|
| 4 | Click <b>Next</b> . |
|---|---------------------|

**Step**      **Action**

- 5      The destination directory path will be automatically loaded.  
Click **Next**.

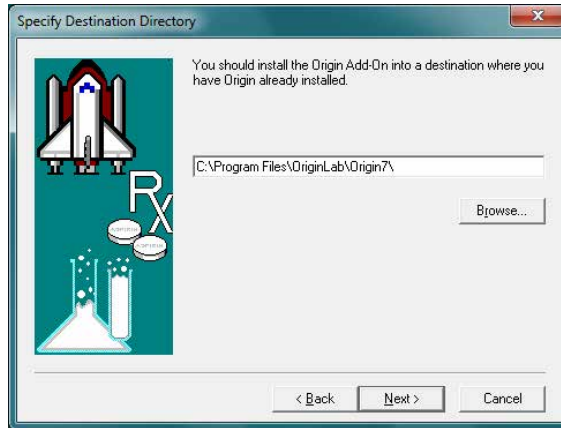

- 6      The software prompts for the add-on disc.



**Note:**

*All add-on software is located on the analysis software installation disc and there is no need to insert any additional disc.*

- 7      Specify the path for the disc by clicking the **Browse** button.  
8      Select the CD drive that has the analysis software installation disc in it.

**Tip:**

This is usually the D: \ drive.

### 3 Installation

#### 3.2 Installing MicroCal iTC<sub>200</sub> software

##### 3.2.1 Updating the software

- | Step | Action  |
|------|---|
| 9    | Double-click on the custom folder, <b>addon_disk_7.20</b> and click <b>OK</b> . |



The path is now specified.

- 10 Click **OK** to continue.  
It may take a few minutes for the files to be installed.
- 11 Once the files have been installed, follow the on-screen instructions.
- 12 Click **Finish** to complete the installation.

After installing all the applications, exit the main menu, remove the CD and keep it in a safe place.

Restart the PC to complete the setup.



## 3.2.2 Complete installation of the software

**Note:** Installation of software requires administrative privileges.

### Installing the control software

The control software CD contains the following applications:

- MicroCal iTC<sub>200</sub> software
- USB driver for injector
- USB driver for data acquisition
- InitDT service
- .Net runtime

To install the control software, follow the steps described below:

#### Installing the MicroCal iTC<sub>200</sub> software

To install the MicroCal iTC<sub>200</sub> software, follow the steps described below:

Step	Action
------	--------

- |   |   |
|---|---|
| 1 | Insert the CD into the CD-ROM drive of the PC.<br>The CD runs automatically and the <b>MicroCal Setup</b> window appears. |
|---|---|

**Note:**

If the CD does not start automatically, run **iTC200Setup.exe** from the CD.



- |   |  |
|---|--|
| 2 | Click on the <b>iTC200 Software Full Install</b> button for the installation to start automatically. |
| 3 | Follow the on-screen instructions and click <b>Finish</b> when the installation is complete.         |

## 3 Installation

### 3.2 Installing MicroCal iTC<sub>200</sub> software

#### 3.2.2 Complete installation of the software

Step	Action
4	Restart the computer.



Be sure to select the option to restart the computer. Shortcut icons are created on the desktop automatically.

#### Installing the driver for the injector USB

To install the USB driver for the injector, click the **Injector USB Driver** button in the main menu to start the installation. A command window opens while the driver is being installed. This window closes automatically when the driver installation is complete.

#### Installing the driver for data acquisition USB

To install the USB driver for data acquisition, follow the steps described below:

Step	Action
1	Click the <b>Data Acquisition USB driver</b> button in the main menu.
2	Follow the on-screen instructions.
3	Click <b>Finish</b> when the installation is complete.

#### Installing .Net runtime

**Note:** *Installation of .Net runtime is necessary before installing InitDT service.*

To install the .Net runtime application, follow the steps described below:

Step	Action
1	Click the <b>Install .Net Runtime</b> button.
2	Follow the on-screen instructions.
3	Click <b>Finish</b> to complete the setup.

## Installing InitDT service

**Note:** The *InitDT* service is a low level service that runs in the background of the MicroCal iTC<sub>200</sub> software. This service operates only in the Windows administrator mode.

To install the InitDT service, follow the steps described below:

Step	Action
------	--------

- |   |  |
|---|--|
| 1 | Click the <b>Install InitDT Service</b> button.              |
| 2 | Follow the on-screen instructions. Use the default settings. |

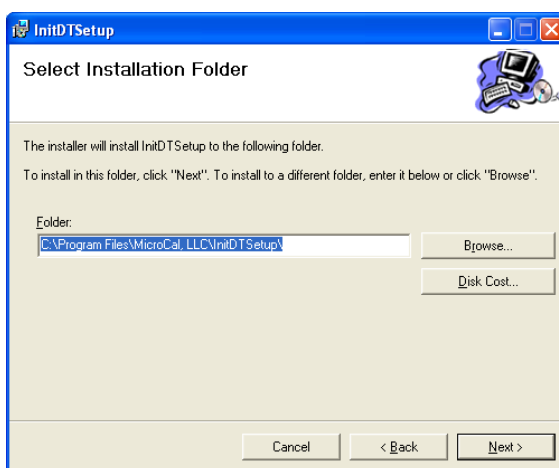

- |   |  |
|---|--|
| 3 | Click <b>Next</b> to continue with the installation.                     |
| 4 | Click <b>Close</b> to exit the setup after the installation is complete. |

After installing the applications, exit the main menu, remove the CD and keep it in a safe place.

Restart the PC to complete the setup.

## Installing analysis software

The MicroCal iTC<sub>200</sub> Analysis Software and License CD (formerly called the Origin analysis software installation CD) contains the following applications:

- Origin 7.0 (for scientific graphing and analysis)
- Origin Service Pack 4

### 3 Installation

#### 3.2 Installing MicroCal iTC<sub>200</sub> software

##### 3.2.2 Complete installation of the software

- MicroCal AddOn for Origin 7.0 (for data analysis specific to MicroCal iTC<sub>200</sub> applications)

To install the analysis software follow the steps described below:

Step	Action
------	--------

- |   |   |
|---|---|
| 1 | Insert the CD into the CD-ROM drive of the PC.<br>The CD runs automatically and the <b>MicroCal's Setup</b> window appears. |
|---|---|

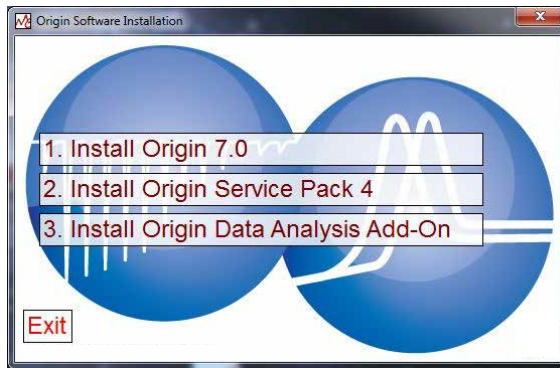

- |   |   |
|---|---|
| 2 | Install each application in the main menu as described later in this section. |
|---|---|

#### Installing Origin 7.0

To install Origin 7.0, follow the steps described below:

Step	Action
------	--------

- |   |  |
|---|--|
| 1 | Click the <b>1. Install Origin 7.0</b> button to start the installation. |
| 2 | Click on <b>Origin 7.0</b> in the pop-up window.                         |

**Step**      **Action**

- 3 Follow the on-screen instructions to continue.  
The **Origin Setup** window for **Customer Information** appears.

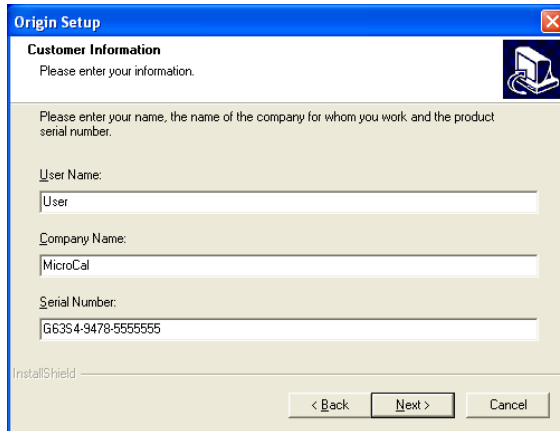

- 4 Enter the **User Name** and **Company Name**.
- 5 Locate the serial number on the front of the CD case or on the Origin box.  
Enter this number including the dashes, in the **Serial Number** text box.
- 6 Click **Next**.  
The **Origin Setup** window for **Destination Directory** appears.

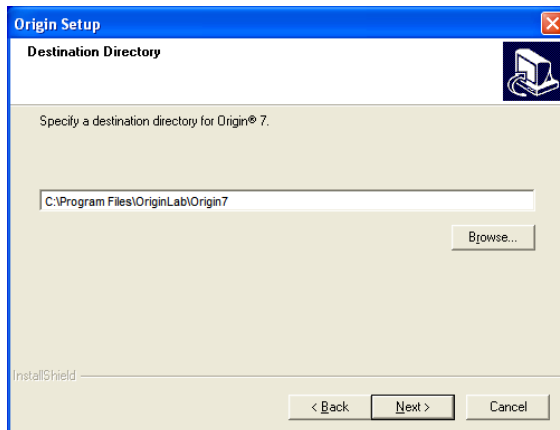

### 3 Installation

#### 3.2 Installing MicroCal iTC<sub>200</sub> software

##### 3.2.2 Complete installation of the software

Step	Action
7	The destination directory path will be automatically loaded. Click <b>Next</b> .
8	Follow the on-screen instructions. It is recommended to use the default settings.
9	Click <b>Finish</b> to complete the installation.
10	Exit the Origin 7.0 setup.

#### Installing Origin Service Pack 4

To install Origin Service Pack 4, follow the steps described below:

Step	Action
1	Click the <b>2. Install Origin Service Pack 4</b> button.
2	Follow the on-screen instructions.
3	Click <b>OK</b> to acknowledge the <b>Patch Warning</b> pop-up.

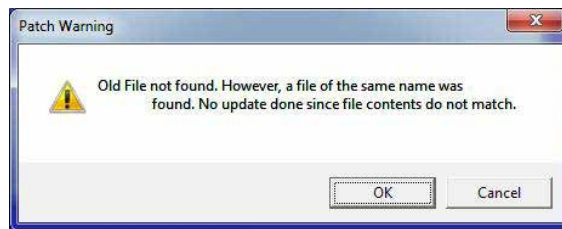

#### Installing Origin Data Analysis Add-On

To install the Origin Data Analysis Add-On, follow the steps described below:

Step	Action
1	Click the <b>Install Origin Data Analysis Add-On</b> button.  <b>Note:</b> <i>Make sure that the <b>Yes, I wish to install an Add-On disk now</b> option is checked in the pop-up window.</i>
2	Click <b>Next</b> .
3	The destination directory path will be automatically loaded. Click <b>Next</b> .

**Step**      **Action**

- 4              The software prompts for the addon disc.



**Note:**

*All addon software is located on the analysis software installation disc and there is no need to insert any additional disc.*

- 5              Specify the path for the disc by clicking the **Browse** button.  
6              Select the CD drive that has the analysis software installation disc in it.

**Tip:**

Tip: This is usually the D:\ drive.

- 7              Double click on the custom folder, **custom\_d\_itc\_200** and click **OK**.

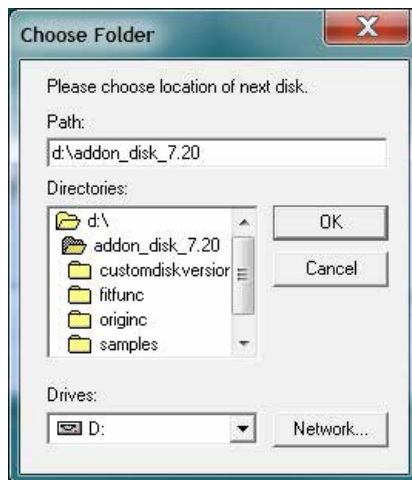

The path is now specified.

- 8              Click **OK** to continue.  
It may take a few minutes for the files to be installed.

### 3 Installation

#### 3.2 Installing MicroCal iTC<sub>200</sub> software

##### 3.2.2 Complete installation of the software

Step	Action
9	Once the files have been installed, follow the on-screen instructions.
10	Click <b>Finish</b> to complete the installation.

After installing all the applications, exit the main menu, remove the CD and keep it in a safe place.

Restart the PC to complete the setup.

---



## 3.3 Settings for Windows 7

After a full installation on a Windows 7 operating system running computer, the configurations described in:

- *Section 3.3.1 Modify the Origin 7 configuration for Windows 7, on page 50,*
- *Section 3.3.2 Modify the MicroCal iTC<sub>200</sub> software configuration for Windows 7, on page 52, and*
- *Section 3.3.3 Modify the user account control settings for Windows 7, on page 54* must be made.

## 3 Installation

### 3.3 Settings for Windows 7

#### 3.3.1 Modify the Origin 7 configuration for Windows 7

### 3.3.1 Modify the Origin 7 configuration for Windows 7

**Note:** *This procedure is only required if you are installing software on a PC with a Windows 7 operating system. If the operating system is Windows XP, skip this procedure and move to the next procedure.*

Step	Action
1	Click the <b>Start</b> button on the Windows 7 operating computer, select <b>Computer</b> , and then navigate to the Origin installation folder, C:\Program Files\OriginLab\Origin7.
2	Locate and right-click the Origin 7 application file, <b>Origin70.exe</b> and select <b>Properties</b> .
3	In the Origin70 Properties dialog box, select the <b>Compatibility</b> tab and then click <b>Change settings for all users</b> .
4	In the Compatibility for all users dialog box, make the following modifications: <ul style="list-style-type: none"><li>• Under Compatibility mode, select <b>Run this program in compatibility mode for:</b>, and then select <b>Windows XP (Service Pack 3)</b>.</li><li>• Under Privilege Level, select <b>Run this program as an administrator</b>.</li><li>• Click <b>OK</b>.</li></ul>

**Step**      **Action**

5      In the **Origin70 Properties** dialog box, click **OK**.

In the next image, all five steps required to make Origin compatible with Windows 7 are displayed.

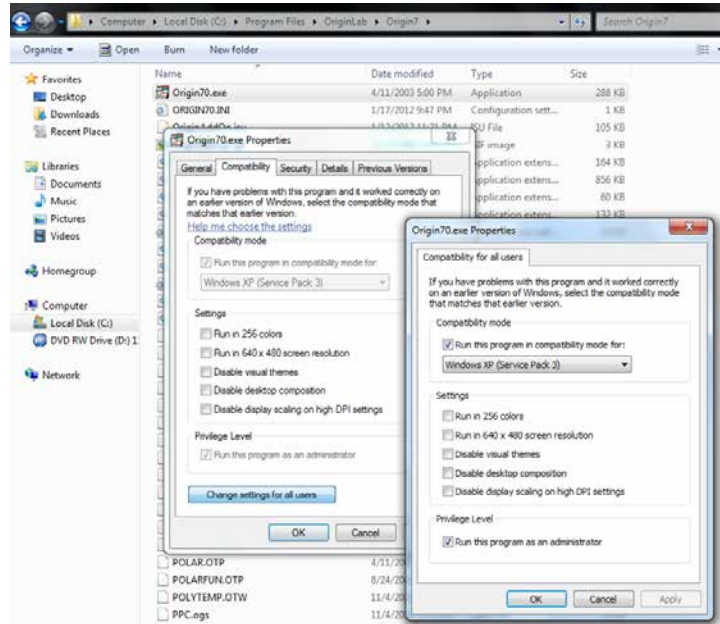

### 3 Installation

#### 3.3 Settings for Windows 7

##### 3.3.2 Modify the MicroCal iTC<sub>200</sub> software configuration for Windows 7

## 3.3.2 Modify the MicroCal iTC<sub>200</sub> software configuration for Windows 7

**Note:** *This procedure is only required if you are installing software on a PC with a Windows 7 operating system. If the operating system is Windows XP, skip this procedure and move to the next procedure.*

Step	Action
1	Click the <b>Start</b> button on the Windows 7 operating computer, select <b>Computer</b> , and then navigate to the ITC <sub>200</sub> installation folder, C:\ITC200.
2	Locate and right-click the ITC <sub>200</sub> application file, <b>ITC200.exe</b> and select <b>Properties</b> .
3	In the ITC <sub>200</sub> Properties dialog box, select the <b>Compatibility</b> tab and then click <b>Change settings for all users</b> .
4	In the Compatibility for all users dialog box, make the following modifications: <ul style="list-style-type: none"><li>• Under Compatibility mode, select <b>Run this program in compatibility mode for:</b>, and then select <b>Windows XP (Service Pack 3)</b>.</li><li>• Under Privilege Level, select <b>Run this program as an administrator</b>.</li><li>• Click <b>OK</b>.</li></ul>

Step	Action
------	--------

5	In the <i>ITC200 Properties</i> dialog box, click <i>OK</i> .
---	---

In the next image, all five steps required to make ITC<sub>200</sub> compatible with Windows 7 are displayed.

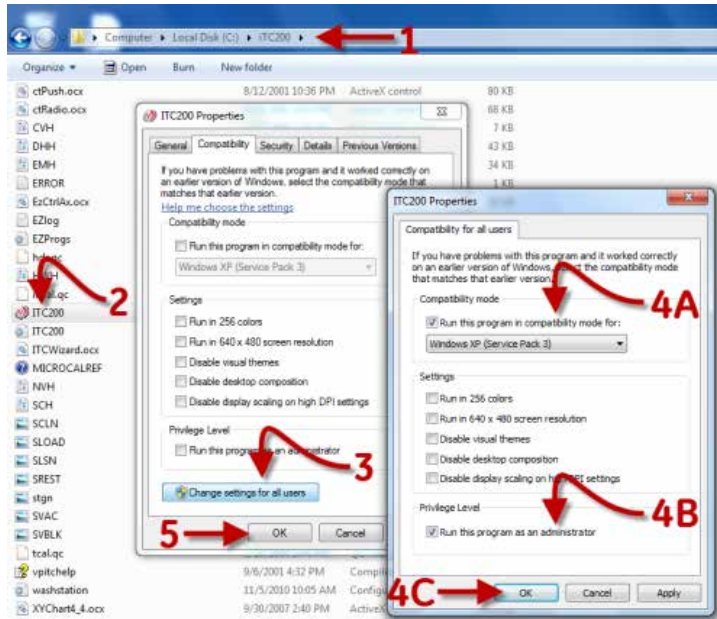

### 3 Installation

#### 3.3 Settings for Windows 7

##### 3.3.3 Modify the user account control settings for Windows 7

### 3.3.3 Modify the user account control settings for Windows 7

**Note:** *This procedure is only required if you are installing software on a PC with a Windows 7 operating system. If the operating system is Windows XP, do not perform this procedure.*

Windows 7 operating systems ship with the user account control settings modified to prevent the following warning message from displaying:



This message can occur if the regional settings are modified and potentially every time the user double-clicks the *ITC<sub>200</sub>* software icon. Although harmless, you should disable the mechanism that causes this to display.

Step	Action
1	Click the <b>Start</b> button on the Windows 7 operating computer, select <b>Control Panel</b> , and then select <b>Action Center</b> .
2	In the left pane of the <b>Action Center</b> window, click <b>Change User Account Control settings</b> .

**Step**      **Action**

3      Drag the notification bar to **Never notify**, and click **OK**.

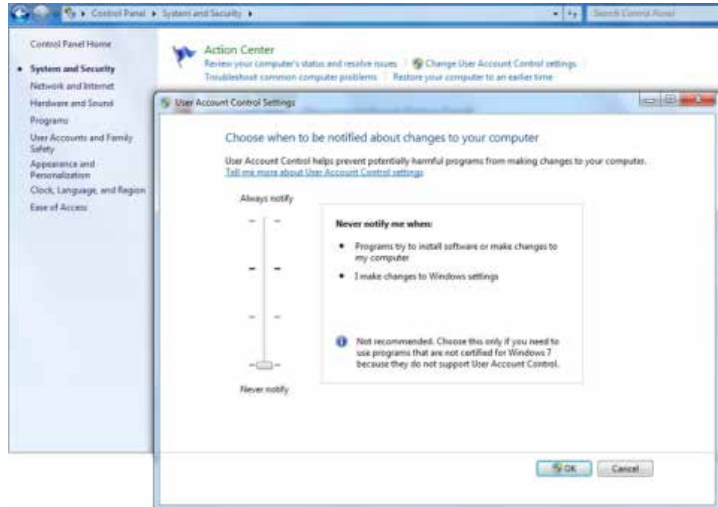

4      Restart the system.

# 4 Control software

## Introduction

This chapter describes the control and data acquisition software that is delivered with MicroCal iTC<sub>200</sub>. The user interfaces are also described in detail. See *Chapter 5 Performing a run, on page 87* for instructions on how to operate MicroCal iTC<sub>200</sub>.

---

## In this chapter

This chapter contains the following sections:

Section	See page
4.1 Overview	57
4.2 MicroCal iTC <sub>200</sub> software	58
4.3 Origin for real-time data display	84

---



## 4.1 Overview

### Software components

The MicroCal iTC<sub>200</sub> is delivered with two software components as outlined in the table below.

Software component	Icon	Description
MicroCal iTC <sub>200</sub> software		This software is used to control MicroCal iTC <sub>200</sub> . See <i>Section 4.2 MicroCal iTC<sub>200</sub> software, on page 58.</i>
Origin	Accessed via the MicroCal iTC <sub>200</sub> software.	Origin is supplied for manual data analysis. See <i>Chapter 6 Data analysis using Origin, on page 118.</i> It is mentioned here, because an instance of Origin may be opened during data collection for real time display, though is not necessary. See <i>Section 4.3 Origin for real-time data display, on page 84</i>

## 4.2 MicroCal iTC<sub>200</sub> software

### Introduction

The MicroCal iTC<sub>200</sub> software controls the calorimeter.

The MicroCal iTC<sub>200</sub> software is able to start an instance of Origin that can be used for real-time data display, see *Section 4.3 Origin for real-time data display, on page 84*. For manual data analysis, a separate instance of Origin should be used, see *Chapter 6 Data analysis using Origin, on page 118*.

This section describes the user interface for the MicroCal iTC<sub>200</sub> software.

---

### In this section

This section contains the following topics:

Section	See page
4.2.1 Starting MicroCal iTC <sub>200</sub> software	59
4.2.2 MicroCal iTC <sub>200</sub> software interface overview	60
4.2.3 MicroCal iTC <sub>200</sub> software control buttons	61
4.2.4 <b>Experimental Design</b> tab	62
4.2.5 <b>Advanced Experimental Design</b> tab	65
4.2.6 <b>Instrument Controls</b> tab	72
4.2.7 <b>Real Time Plot</b> tab	77
4.2.8 <b>Setup</b> tab	78
4.2.9 MicroCal iTC <sub>200</sub> software menus	80

---

## 4.2.1 Starting MicroCal iTC<sub>200</sub> software

The MicroCal iTC<sub>200</sub> software is used to control the MicroCal iTC<sub>200</sub> instrument directly. The software and hardware need to be started in sequence for correct initialization.

To start the MicroCal iTC<sub>200</sub> software, follow the steps described below:

Step	Action
1	Start the computer and log in to Windows.
2	Turn on the MicroCal iTC <sub>200</sub> instrument using the <b>Power</b> switch at the rear of the unit.
3	Start the MicroCal iTC <sub>200</sub> software. <i>Result:</i> The MicroCal iTC <sub>200</sub> software is launched.
4	To open an instance of Origin for real-time data display, select <b>System:Establish DDE Link To Origin</b> .

**Note:**  
*It is normally not necessary to start Origin for real-time data display, since real time data can be viewed directly in the MicroCal iTC<sub>200</sub> software.*

## 4.2.2 MicroCal iTC<sub>200</sub> software interface overview



Part	Function
1	Displays the time left until the end of the run when an experiment is in progress.
2	Menus, see <i>Section 4.2.9 MicroCal iTC<sub>200</sub> software menus, on page 80.</i>
3	Current MicroCal iTC <sub>200</sub> status. On start up, the status <i>System Initiation - Please Wait</i> is displayed. After a few seconds, the system heats or cools to the preset temperature. Once the instrument reaches the set temperature, it thermostats at that temperature.
4	Control buttons, see <i>Section 4.2.3 MicroCal iTC<sub>200</sub> software control buttons, on page 61.</i>
5	Control tabs: <ul style="list-style-type: none"> <li>• <b>Experimental Design</b>, see <i>Section 4.2.4 Experimental Design tab, on page 62.</i></li> <li>• <b>Advanced Experimental Design</b>, see <i>Section 4.2.5 Advanced Experimental Design tab, on page 65.</i></li> <li>• <b>Instrument Controls</b>, see <i>Section 4.2.6 Instrument Controls tab, on page 72.</i></li> <li>• <b>Real Time Plot</b>, see <i>Section 4.2.7 Real Time Plot tab, on page 77.</i></li> <li>• <b>Setup</b>, see <i>Section 4.2.8 Setup tab, on page 78.</i></li> </ul>

## 4.2.3 MicroCal iTC<sub>200</sub> software control buttons

The control buttons are used to save and load experimental run parameters, display and update current run parameters and to start and stop a run.

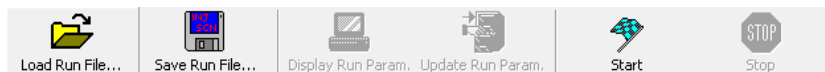

Part	Function
<b>Load Run File...</b>	<p>Loads previously saved parameters. The parameters are loaded into the <b>Advanced Experimental Design</b> tab.</p> <p>Run parameters can be loaded from two types of files:</p> <ul style="list-style-type: none"> <li>• A data file from a previous experiment (*.itc)</li> <li>• A setup file (*.inj)</li> </ul>
<b>Save Run File...</b>	<p>Saves the currently displayed run parameters to a setup file (*.inj)</p>
<b>Display Run Param.</b>	<p>Displays the current run parameters for a run in progress. This button is active when MicroCal iTC<sub>200</sub> is in a non-idle state.</p>
<b>Update Run Param.</b>	<p>Updates the run parameters for a run in progress. Most commonly, this would include changing injection parameters. In some instances, experimental parameters may be changed while a run is in progress, but it is not advised.</p> <p>This button must be clicked for run parameter changes to take effect.</p>
<b>Start</b>	<p>Starts the run using the current parameters present in the <b>Advanced Experimental Design</b> tab.</p> <p>Check that all parameters are correct and that a valid, unique data file name has been entered before clicking this button. The system prompts for confirmation if any files will be overwritten.</p>
<b>Stop</b>	<p>Aborts the run immediately.</p>

## 4.2.4 *Experimental Design* tab

The ***Experimental Design*** tab permits the user to simulate basic experimental runs. Three experimental modes are available with different recommended protocols.

For greater control over injection protocols, the ***Advanced Experimental Design*** tab is used. See Section 4.2.5 ***Advanced Experimental Design*** tab, on page 65.

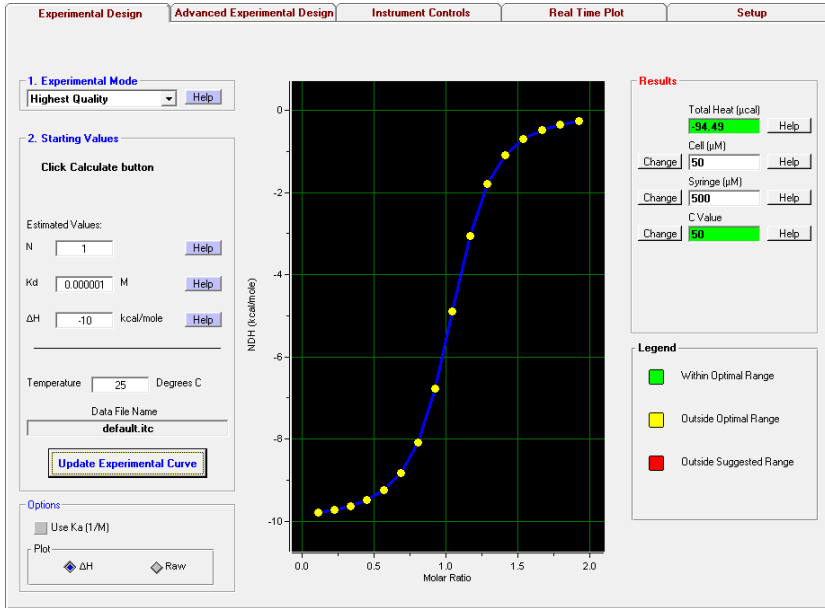

Part	Function
<b>Experimental Mode</b>	<p>Choose an experimental mode. The three modes available are:</p> <ul style="list-style-type: none"> <li>• <b>Highest Quality</b> This uses 20 injections and a c-value of 100. These parameters produce data that is clear and easy to fit.</li> <li>• <b>Minimum Protein</b> This uses 10 injections and a c-value of 5, resulting in the use of the least amount of sample necessary for a successful titration.</li> <li>• <b>High Speed</b> This simulates one long, six-minute injection and automatically populates the <b>Advanced Experimental Design</b> tab with single-injection mode run parameters. See <i>Section 6.6.14 Single injection method (SIM), on page 238</i>.</li> </ul> <p>More information about c-value and calculating cell concentration can be found under <i>Section 5.1.4 Calculating cell concentrations, on page 93</i>.</p>
<b>N</b>	Enter the number of binding sites, n, if this is known. Press <b>enter</b> to move on to $K_D$ .
<b>Kd</b>	Enter the estimated binding constant, $K_D$ , if known. Click the <b>Help</b> button for guidance depending on sample and titrant. Press <b>enter</b> to move on to $\Delta H$ .
<b><math>\Delta H</math></b>	Enter the estimated heat of binding, $\Delta H$ , if known.
<b>Temperature</b>	Enter the desired run temperature.
<b>Update Experimental Curve</b>	Calculates a simulated result that is displayed in the plot in the center of the tab area.
<b>Use Ka (1/M)</b>	Selecting this option uses a binding constant ( $K_A$ ) instead of a dissociation constant ( $K_D$ ).
<b>Plot</b>	Select whether to view the simulation plot using raw heat per injection ( <b><math>\Delta H</math></b> ) or the heat normalized to the molar ratio ( <b>Raw</b> ).

Part	Function
<b>Results</b>	<p>This area displays values for cell concentration, syringe concentration, and a c-value that predicts the sigmoidicity of the curve. These values may be changed by clicking the corresponding <b>Change</b> button. Also, click the <b>Help</b> button for explanations.</p> <p>The <b>C Value</b> box is color coded as specified in the <b>Legend</b> box below. Optimal values will provide the best experimental results. Values that are outside of optimal range will not yield the best results. Values that are extremely outside of optimal range may not yield usable data.</p>

**Tip:** *Warnings, such as, Heats too high for the instrument to measure, appear in the status bar near the top of the tab. Carefully look at the simulated curve and make sure that the shape and values are reasonable before commencing a run.*



## 4.2.5 *Advanced Experimental Design* tab

### Overview

The *Advanced Experimental Design* tab permits detailed specification of the run parameters.

Part	Function
1	The controls in the <i>Experimental Parameters</i> area are used to change general parameters for the experimental run. See <i>Experimental parameters, on page 66</i> .
2	The controls in the <i>Injection Parameters</i> area are used to change injection parameters. The current parameters are displayed in the injection list. See <i>Injection parameters, on page 68</i> .
3	The injection list shows the parameters for each injection that will be performed during the run.
4	The simulated graph is calculated based on values from the <i>Experimental Design</i> tab but can be altered here based on the entries in the <i>Experimental Parameters</i> area. See <i>Experimental parameters, on page 66</i> .

### 3 Installation

#### 3.1 Setting up MicroCal iTC<sub>200</sub> before a run

##### 3.1.1 Fluid connections

Step	Action
------	--------

---

- 4 Insert the waste line (connected to the C5 port on the washing module) into the grey (waste) bottle and tighten the securing nut until it is finger tight.



- 5 Bundle the three fluid lines from the adapter and position them so they will not interfere with your experiments.
-

Part	Function								
<b>Reference Power</b>	<p>Enter a value for reference power. The raw signal (DP) baseline will equilibrate near this value.</p> <p>The reference power is a small constant amount of power supplied to the offset heater of the reference cell. This causes the DP feedback system to supply compensating power to the sample cell to equilibrate the temperatures. The best choice for the reference power setting can be determined by the anticipated size and sign of the titration heats. The table below gives some guidelines.</p> <table border="1"> <thead> <tr> <th>Expected reaction type</th> <th>Suggested reference power</th> </tr> </thead> <tbody> <tr> <td>Large exothermic</td> <td>Large value (~10 <math>\mu\text{cal/s}</math> using high feedback)</td> </tr> <tr> <td>Large endothermic</td> <td>Small value (~0.5 <math>\mu\text{cal/s}</math>)</td> </tr> <tr> <td>Unknown</td> <td>Intermediate value (5 <math>\mu\text{cal/s}</math> using high feedback)</td> </tr> </tbody> </table> <p><b>Note:</b>  <i>The titration heats must not cause the DP to exceed the usable range (0 to 4.15 - passive feedback, 0 to 12.25 - high feedback, etc.).</i></p>	Expected reaction type	Suggested reference power	Large exothermic	Large value (~10 $\mu\text{cal/s}$ using high feedback)	Large endothermic	Small value (~0.5 $\mu\text{cal/s}$ )	Unknown	Intermediate value (5 $\mu\text{cal/s}$ using high feedback)
Expected reaction type	Suggested reference power								
Large exothermic	Large value (~10 $\mu\text{cal/s}$ using high feedback)								
Large endothermic	Small value (~0.5 $\mu\text{cal/s}$ )								
Unknown	Intermediate value (5 $\mu\text{cal/s}$ using high feedback)								
<b>Initial Delay</b>	Enter the time (s) between the start of the run and the first injection (standard value 60 s). This is necessary to establish a baseline before the first injection.								
<b>Syringe Concentration</b>	Enter the concentration (mM) in the syringe.								
<b>Cell Concentration</b>	Enter the concentration (mM) in the cell.								
<b>Stirring Speed</b>	Enter the sample cell stirring speed in rpm (recommended value is 1000 rpm). Faster stirring may be necessary if the sample cell contains suspended particles, for example, agarose beads.								
<b>Data File Name</b>	Enter the data file name (itc.file). For best file naming, see <i>File naming recommendation</i> , on page 71.								

## 4 Control software

### 4.2 MicroCal iTC<sub>200</sub> software

#### 4.2.5 *Advanced Experimental Design* tab

Part	Function
<b>Feedback Mode/Gain</b>	The feedback mode affects both response time and sensitivity. High gain provides the fastest response time. No gain (passive mode, <b>None</b> ) provides the highest sensitivity. Most ITC reactions require using the <b>High</b> setting. Monitoring long, slow thermal processes (for example, kinetics, metabolic rates) might benefit from using the <b>None</b> (passive) or <b>Low</b> settings.
<b>Kd</b>	Displays the value entered in <i>Section 4.2.4 Experimental Design tab, on page 62</i> .
<b>dH</b>	Displays the value entered in <i>Section 4.2.4 Experimental Design tab, on page 62</i> .
<b>Update Experimental Curve</b>	Updates the simulated experimental curve, based on the parameters displayed above in the <b>Experimental Parameters</b> area.

## Injection parameters

The **Injection Parameters** and injection list are described below.

**Note:** *The injection parameters can be changed during a run but will be applied only when the **Update Run Param.** button is clicked*

**Injection Parameters**

<b>Volume (µl)</b>	<b>2</b>
<b>Duration (sec.)</b>	<b>4</b>
<b>Spacing (sec.)</b>	<b>150</b>
<b>Filter Period (sec.)</b>	<b>1</b>

**Edit Mode**

All Same     
  Unique     
  Apply To Rest

	Volume	Duration	Spacing	Filter
1	0.4	0.8	150	1
2	2.0	4.0	150	1
3	2.0	4.0	150	1
4	2.0	4.0	150	1
5	2.0	4.0	150	1
6	2.0	4.0	150	1
7	2.0	4.0	150	1
8	2.0	4.0	150	1
9	2.0	4.0	150	1
10	2.0	4.0	150	1
11	2.0	4.0	150	1
12	2.0	4.0	150	1
13	2.0	4.0	150	1
14	2.0	4.0	150	1

Part	Function
<b>Volume (µL)</b>	Enter the volume (µl) of titrant to be injected from the pipette into the sample cell for the injection(s) selected in the injection list.
<b>Duration (sec.)</b>	Enter the time (s) that the instrument should take to inject the titrant into the sample cell for the injection(s) selected in the injection list.  The default value is twice the value entered in the <b>Volume</b> text box for the multiple injection method, and ten times the value entered in the <b>Volume</b> text box for the single injection method.

Part	Function								
<b>Spacing (sec.)</b>	<p>Enter the time (s) between the beginning of the injection(s) selected in the injection list and the beginning of the next injection (or end of run).</p> <p>The injection spacing must allow enough time between injections to allow the DP signal to return to the baseline after an injection peak deflection. Typical values for this parameter range from 90 to 180 s, depending on the feedback mode, temperature and reaction kinetics.</p> <p><b>Note:</b> <i>For the single injection method, the spacing should be at least 90 s greater than the duration.</i></p>								
<b>Filter Period (sec.)</b>	<p>Enter the time period (s) over which data channel conversions are averaged to smooth the data. A longer filter period will result in smoother data, at the cost of time resolution. However, data will always be read out at a 1 s interval.</p>								
<b>Edit Mode</b>	<p>Select the edit mode for the injection list.</p> <table border="1"> <thead> <tr> <th>Edit Mode</th> <th>Description</th> </tr> </thead> <tbody> <tr> <td><b>All Same</b></td> <td>All injections will have the same parameters</td> </tr> <tr> <td><b>Unique</b></td> <td>Only the selected injection(s) will be altered</td> </tr> <tr> <td><b>Apply To Rest</b></td> <td>Applies the parameters for the currently selected injection to all subsequent injections</td> </tr> </tbody> </table>	Edit Mode	Description	<b>All Same</b>	All injections will have the same parameters	<b>Unique</b>	Only the selected injection(s) will be altered	<b>Apply To Rest</b>	Applies the parameters for the currently selected injection to all subsequent injections
Edit Mode	Description								
<b>All Same</b>	All injections will have the same parameters								
<b>Unique</b>	Only the selected injection(s) will be altered								
<b>Apply To Rest</b>	Applies the parameters for the currently selected injection to all subsequent injections								
<b>Injection list</b>	Select the injection(s) to edit in the injection list.								

The user should also remember that:

- Injection parameters and some experimental parameters can be changed during a run or just before a run starts, respectively. Clicking the **Update Run Param.** control button will apply those changes.
- The plot on the bottom left corner is tied to the values displayed in both the experimental and injection parameters areas. Changing cell and syringe concentrations, and the injection parameters and clicking the **Update Experimental Curve** button affects this plot.

## File naming recommendation

When reading multiple datasets into Origin, the last 10 characters of the file name (excluding the file extension and underscore characters) must be unique and not start with a numeric value. Incorrect naming can be corrected by renaming the files manually. This only affects the simultaneous analysis of multiple datasets. Single datasets can always be read into Origin.

### Examples of good file names:

File Name	Reason name is good	Resulting Origin worksheet name
011511_1.itc 011511_2.itc	Although name starts with a number, the name is under ten characters and thus the last digit is not truncated. The resulting Origin worksheet names are unique.	a0115111 a0115112
Test_011511_1.itc Test_011511_2.itc	The tenth character is not numeric and thus the last digit is not truncated. The resulting Origin worksheet names are unique.	est0115111 est0115112

### Examples of bad file names:

File Name	Reason name is bad	Resulting Origin worksheet name
011511_test1.itc 011511_test2.itc	Because a number was the tenth character, a letter is added as a prefix and the last character is truncated. Since the last character was the unique character, the worksheet names are now identical and will not load properly in Origin.	a11511test a11511test
My EDTA Test 01Sept2011_1.itc My EDTA Test 01Sept2011_2.itc		a1Sept2011 a1Sept2011

## 4.2.6 *Instrument Controls* tab

### Overview

The *Instrument Controls* tab contains controls for direct operation and basic maintenance of the MicroCal iTC<sub>200</sub> instrument. The tab is illustrated below.

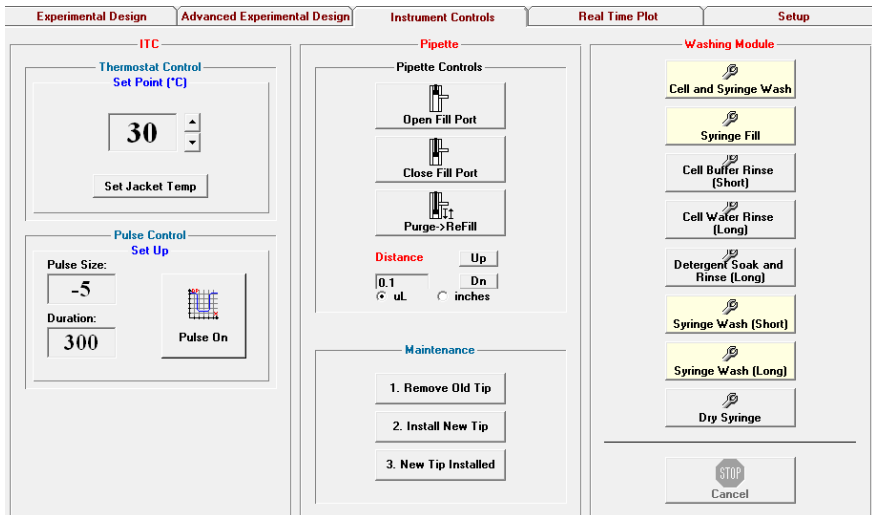

Part	Function
1	The <i>ITC</i> control pane contains controls for thermostat control and for administration of a calibration pulse. See <i>ITC control pane, on page 72</i> .
2	The <i>Pipette</i> control pane helps in cleaning the syringe and changing the plunger tip, which should be done when wear is visible (see <i>Chapter 7 Maintenance, on page 253</i> ). See <i>Pipette control pane, on page 74</i> .
3	The <i>Washing Module</i> control pane permits loading of the syringe and cleaning of the instrument. See <i>Washing Module control pane, on page 75</i>

### *ITC* control pane

The thermostat and pulse controls are described below.

The **Thermostat Control** is used to manually set the temperature of the MicroCal iTC<sub>200</sub> instrument.

**Note:** *The MicroCal iTC<sub>200</sub> software will take control if a run is started.*

The **Pulse Control** is used to administer a DP calibration pulse. This is not intended for normal operation.



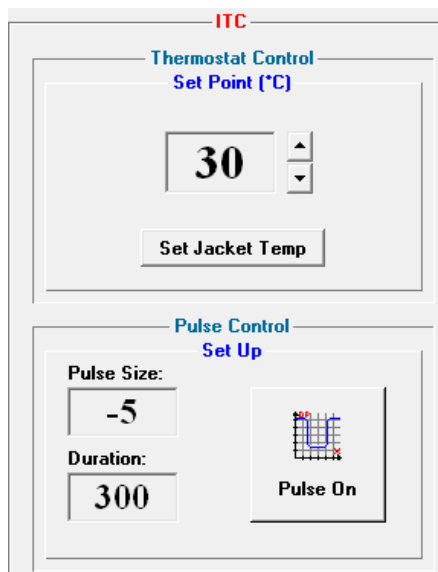

Part	Function
<b>Set Point</b>	Use the arrow buttons to set the desired thermostat temperature. Click the <b>Set Jacket Temp</b> button to apply the change.
<b>Set Jacket Temp</b>	Starts thermostating MicroCal iTC <sub>200</sub> at the temperature specified in the <b>Set Point</b> box.
<b>Pulse Size</b>	Enter the size of the calibration pulse, in units of $\mu\text{cal/s}$ .
<b>Duration</b>	Enter the duration of the calibration pulse in seconds.
<b>Pulse On</b>	Starts the calibration pulse.

## Pipette control pane

The pipette controls are described below.

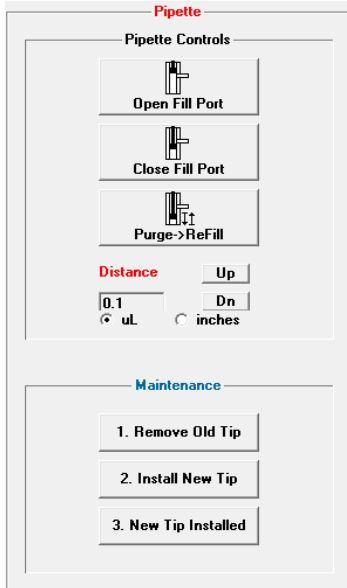

Part	Function
<b>Open Fill Port</b>	Moves the plunger tip to a position above the fill port on the side of the syringe.
<b>Close Fill Port</b>	Moves the plunger tip down so that it blocks the fill port.
<b>Purge-&gt;Refill</b>	Pushes the pipette tip all the way down and back up again, to dislodge bubbles, if any, on the sides of the syringe.
<b>Distance</b>	Enter the distance (by volume, $\mu\text{L}$ or in inches) to move the pipette tip up or down.
<b>Up</b>	Moves the pipette tip up by the distance specified in the <b>Distance</b> text box.
<b>Dn</b>	Moves the pipette tip down by the distance specified in the <b>Distance</b> text box.
<b>Remove Old Tip</b>	Positions the plunger appropriately for tip removal.
<b>Install New Tip</b>	Positions the plunger appropriately to install the tip.
<b>New Tip Installed</b>	Positions the plunger appropriately to install the syringe.

## Washing Module control pane

The **Washing Module** control pane is described below.

The basic washing operation is described in *Section 5.3 Cleaning the cell and syringe before performing an experiment, on page 103.*

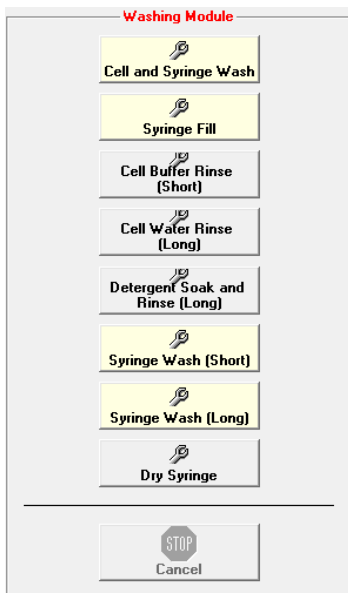

Part	Function
<b>Cell and Syringe Wash</b>	Cell wash with buffer Syringe wash with water and methanol, followed by drying
<b>Syringe Fill</b>	Fills the syringe with titrant from the micro-centrifuge tube
<b>Cell Buffer Rinse (Short)</b>	Cell rinse with buffer
<b>Cell Water Rinse (Long)</b>	Extended rinse of the cell with water
<b>Detergent Soak and Rinse (Long)</b>	Manual detergent soak and automated water rinse of cell
<b>Syringe Wash (Short)</b>	Standard syringe rinse with water and methanol, followed by drying
<b>Syringe Wash (Long)</b>	Extended syringe rinse with water and methanol, followed by drying
<b>Dry Syringe</b>	Syringe drying

## 4 Control software

### 4.2 MicroCal iTC<sub>200</sub> software

#### 4.2.6 *Instrument Controls* tab

Part	Function
<b>Cancel</b>	One click: stops current procedure and empties waste Additional click: cancels emptying of waste

## 4.2.7 Real Time Plot tab

The **Real Time Plot** tab displays the current data. If no run has been started, the graph will be blank. The contents of the tab are described below.

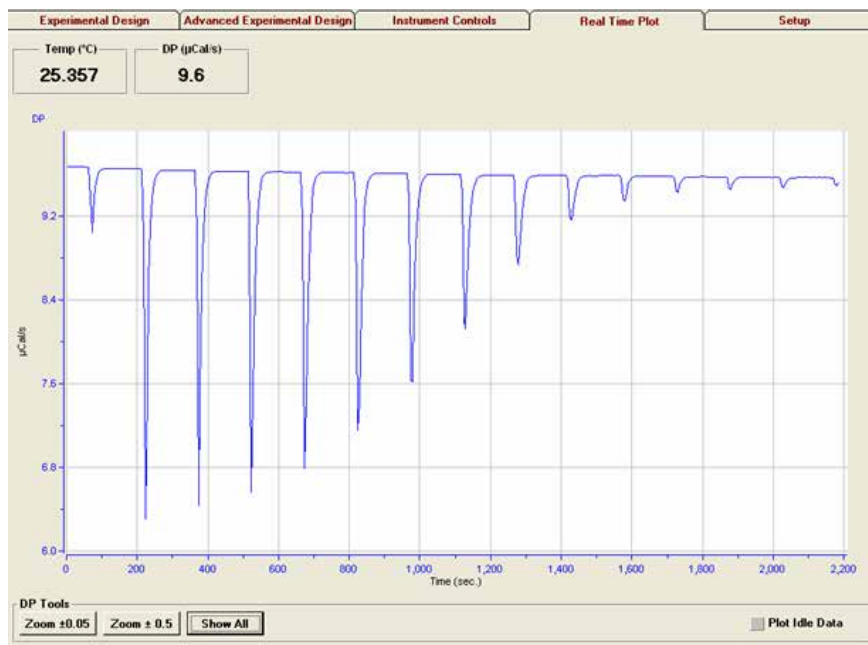

Part	Function
<b>Temp (°C)</b>	Displays the current temperature of the MicroCal iTC <sub>200</sub> instrument.
<b>DP (µCal/s)</b>	Displays the current MicroCal iTC <sub>200</sub> DP measurement.
<b>Zoom ±0.05</b>	Changes the vertical range to the last data point, plus or minus 0.05 µCal/s.
<b>Zoom ± 0.5</b>	Changes the vertical range to the last data point plus or minus 0.5 µCal/s.
<b>Show All</b>	Rescales the y-axis so that all the data points are visible.
<b>Plot Idle Data</b>	Selecting this option plots the current DP readings even if no run is currently being performed.

## 4.2.8 Setup tab

The **Setup** tab contains some miscellaneous functions that are illustrated and described below. The functionality described below is available only if the DDE link is established with Origin. (**System:Establish DDE Link to Origin**).

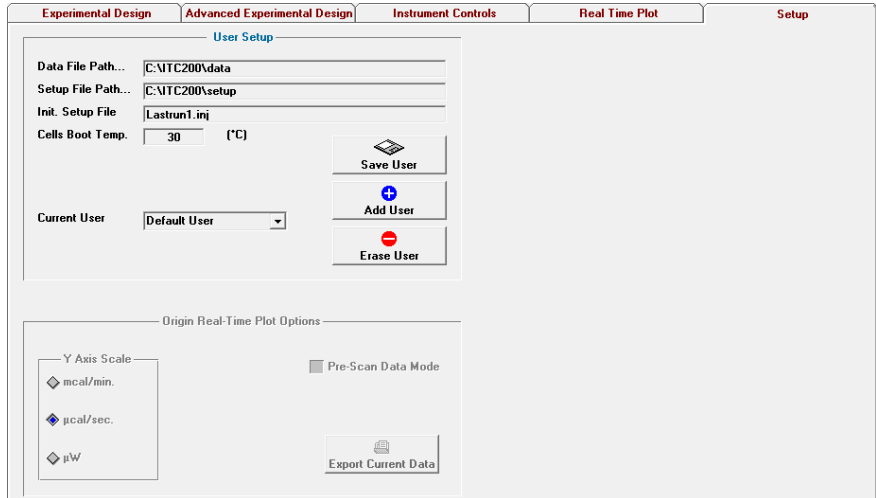

Part	Function
<b>Data File Path</b>	File path where data is saved.
<b>Setup File Path</b>	File path where .inj files are saved.
<b>Init. Setup File</b>	Default .inj file.
<b>Cells Boot Temp.</b>	Default cell temperature.
<b>Current User</b>	Saved user profiles of the current user.
<b>Save User</b>	Save these settings to a user profile.
<b>Add User</b>	Add a new user.
<b>Erase User</b>	Erase a user.
<b>Y Axis Scale</b>	Select the units in which the data should be displayed. Only the display will be affected, the data is always stored in µcal/s. The three choices are: <ul style="list-style-type: none"> <li>• mcal/min</li> <li>• µcal/sec (Default)</li> <li>• µWatt</li> </ul>

Part	Function
<b>Pre-Scan Data Mode</b>	<p>Checking this box saves all data, including measurements that are taken before the run is started. Each scan will provide an additional *.dat file with the same name as the *.itc file. This data provides service personnel with extra data for the purpose of troubleshooting.</p> <p><b>Note:</b>  <i>This option requires Origin for real-time data display to be open. Select <b>System:Establish DDE Link To Origin</b> to open it.</i></p>
<b>Export Current Data</b>	<p>Click this button to export and save the data that is currently displayed in the <b>Real Time Plot</b> tab to a file. The system prompts for a file name.</p>

## 4.2.9 MicroCal iTC<sub>200</sub> software menus

### Introduction

The main menus in the MicroCal iTC<sub>200</sub> software provide access to some of the less frequently used features of the application.

The four available menus are:

- **System**, see **System menu**, on page 80
- **ITC**, see **ITC menu**, on page 81
- **Options**, see **Options menu**, on page 81
- **Help**, see **Help menu**, on page 83

### System menu

The **System** menu is illustrated below.

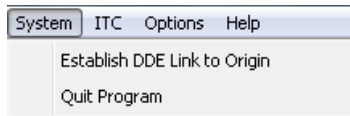

Part	Function
<b>Quit Program</b>	Terminates the application. The system prompts for a confirmation to quit the program. All ITC run data will be saved to disk. After approximately 1 minute, the power to the MicroCal iTC <sub>200</sub> instrument will also be shut down. The application needs to be restarted to restart the system.
<b>Establish DDE Link to Origin</b>	Opens a real time instance of Origin.



## ITC menu

The **ITC** menu is illustrated and described below.

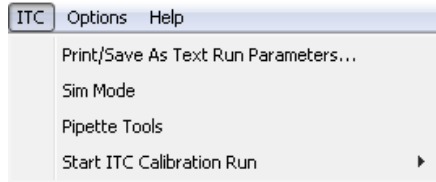

Part	Function
<b>Print/Save As Text Run Parameters...</b>	Prints or saves the run parameters currently loaded in the MicroCal iTC <sub>200</sub> software to a file. Run parameters are always stored in data file headers. Files generated using this option provide a formatted list of run parameters that may be useful for data presentation or general record keeping.
<b>Sim Mode</b>	Is checked if <b>High Speed</b> is selected in the <b>Experimental Design</b> tab. Locks certain experimental parameters.
<b>Pipette Tools</b>	Opens a dialog where syringe calibrations can be adjusted.
<b>Start ITC Calibration Run -&gt;Y Axis Check</b>	Initiates a calibration check to Make sure heat pulses are accurately measured. This is not normally performed by a user.

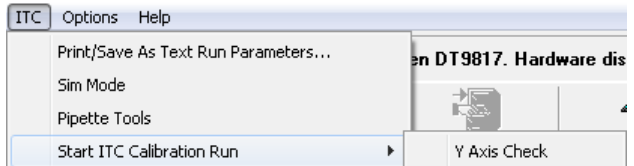

## Options menu

The **Options** menu is illustrated and described below.

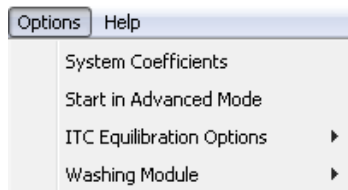

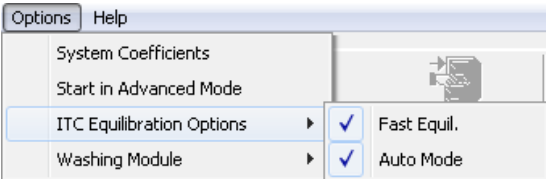
Part	Function
<b>System Coefficients</b>	<p>Opens the <b>System Coefficients</b> dialog, see <b>System Coefficients dialog</b>, on page 83. The values in this dialog should not be changed without direct instruction from a Malvern Instruments service engineer.</p> <p><b>Tip:</b>            The instrument serial number is displayed at the top left of the <b>System Coefficients</b> dialog.</p>
<b>Start in Advanced Mode</b>	<p>Displays the <b>Advanced Experimental Design</b> tab by default when the software is started.</p>
<b>ITC Equilibration Options</b>	 <p>This option has two selectable suboptions that are selected by default. Generally, these options do not need to be deselected unless troubleshooting.</p> <ul style="list-style-type: none"> <li> <p><b>Fast Equil.</b></p> <p>When this option is disabled, the system goes through an additional pre-run, a non-stirring equilibration period before stirring starts. This can be useful if stirring-related noise problems are suspected.</p> </li> <li> <p><b>Auto Mode</b></p> <p>When this option is disabled, the system will not progress automatically from one state to another during the pre-run equilibration period. To move to the next state, double-click on the <b>DP</b> data box in the <b>Real Time Plot</b> tab.</p> <p>When the option is enabled, no user interaction is required once a run has been started.</p> </li> </ul>

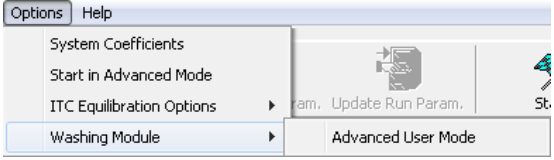
Part	Function
<b>Washing Module -&gt; Advanced User Mode</b>	 <p>Leaving the Washing Module in the Advanced Mode disables many of the prompts displayed during Washing Module Procedures.</p>

### System Coefficients dialog

The **System Coefficients** dialog is illustrated below. It contains the most critical of the calibration constants. The dialog is password protected so that no changes are made by accident. None of these parameters should be changed without direct instruction from a Malvern Instruments service personnel.

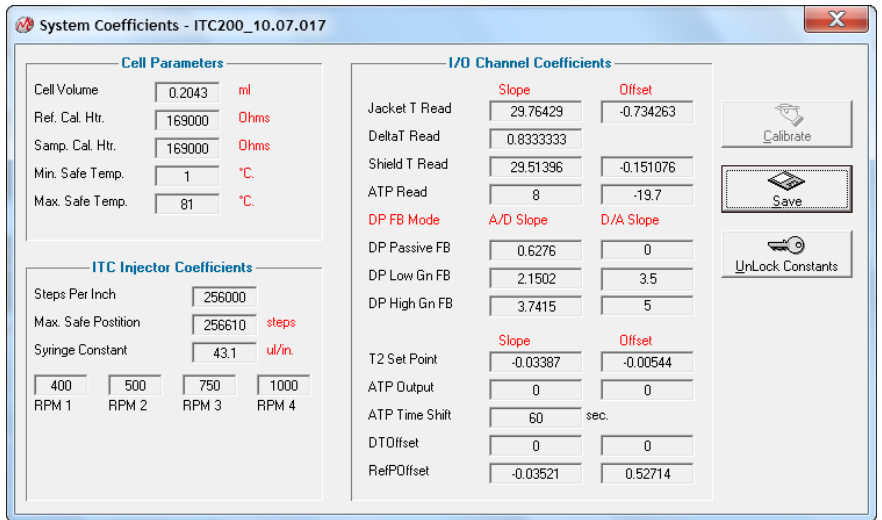

### Help menu

The **Help** menu is illustrated below.



## 4.3 Origin for real-time data display

### Introduction

An instance of Origin for real-time data display can be opened by selecting **System:Establish DDE Link to Origin** in the MicroCal iTC<sub>200</sub> software. This instance is customized for and dedicated to the real-time display of data acquired from the MicroCal iTC<sub>200</sub> instrument.

This section describes the features unique to this customized instance of Origin for real-time data display. For information about data analysis using Origin, refer to *Chapter 6 Data analysis using Origin, on page 118*.

**Note:** *It is normally not necessary to start the Origin for real-time data display, since real time data can be viewed directly in the MicroCal iTC<sub>200</sub> software.*

### Origin for real-time data display main window

The main components of Origin for real-time data display main window are illustrated below:

**Note:** *Origin for real-time data display will always display the file name **VPITC-PLOT.OPJ** in the window border.*

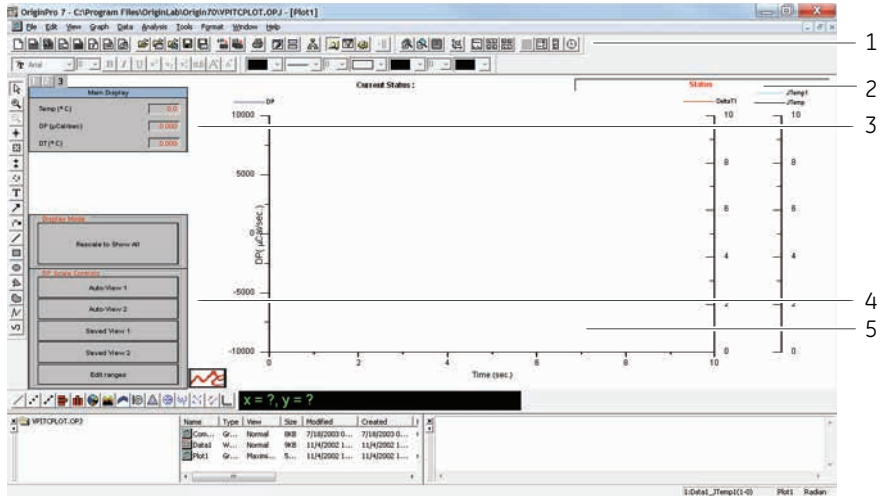

Part	Function
1	Origin main menus, refer to the <i>Origin User Manual</i> .

Part	Function
2	<b>Current Status</b> Displays the current state of the instrument.
3	<b>Main Display</b> Displays the current temperature, DP and temperature difference readings from the instrument.
4	<b>Display Mode and DP Scale Controls</b> Controls the display of MicroCal iTC <sub>200</sub> data, see below.
5	Real time plot area.

### Display Mode and DP Scale Controls buttons

The following table describes the function of the **Display Mode** and **DP Scale Controls** buttons.

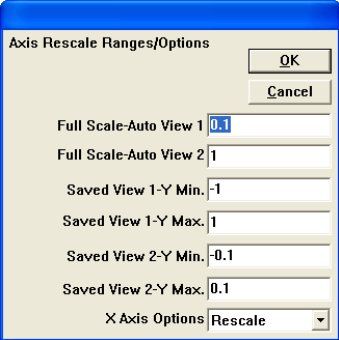

Button	Description
<b>Rescale To Show All</b>	Automatically rescales the x- and y- axes range so that all data fits within the plot area.
<b>Auto-View 1</b> and <b>Auto-View 2</b>	Rescales the y-axis so that the most recent DP data point is centered. The range of the y-axis scale is determined by the value entered in the corresponding box in the <b>Edit Ranges</b> dialog.

Button	Description
<p><b>Saved View 1</b> and <b>Saved View 2</b></p>	<p>Rescales the y-axis to the preset values entered in the corresponding boxes in the <b>Edit Ranges</b> dialog.</p>
<p><b>Edit Ranges</b></p>	<p>Opens the <b>Axis Rescale Ranges/Options</b> dialog.</p>  <ul style="list-style-type: none"> <li>• <b>Full Scale-Auto View 1</b> and <b>Full Scale-Auto View 2</b>: Enter the range(s) to be used for the auto view functions</li> <li>• <b>Saved View</b> text boxes : Enter the range(s) to be used for the save-view functions</li> <li>• <b>X Axis Options</b>: Select the desired x-axis automatic scaling option from the drop-down list       <ul style="list-style-type: none"> <li>- <b>Disabled</b>: No x-axis rescaling is performed</li> <li>- <b>Rescale</b>: The x-axis will be rescaled by 25% when new data is acquired that exceeds the current range</li> <li>- <b>Scroll</b>: The x-axis range will scroll by 25% when new data is acquired that exceeds the current range</li> </ul> </li> </ul>

# 5 Performing a run

## Introduction

This chapter describes the procedure for running MicroCal iTC<sub>200</sub>.

The basic scheme of operation can be outlined as follows:

- **Preparing samples.** Refer to *Section 5.1 Preparing the samples, on page 88.*
  - **Creating a method.** Refer to *Section 5.2 Creating a method, on page 100.*
  - **Loading the samples and performing the experiment.** Refer to *Section 5.4 Loading the samples and performing the experiment, on page 111.*
- 

## In this chapter

This chapter contains the following sections:

Section	See page
5.1 Preparing the samples	88
5.2 Creating a method	100
5.3 Cleaning the cell and syringe before performing an experiment	103
5.4 Loading the samples and performing the experiment	111

---

## 5.1 Preparing the samples

### Introduction

Since proper sample preparation is critical for successful ITC experiments, general guidelines for sample preparation will be discussed here. These guidelines use the terminology of binding experiments using biological samples, but may be readily used for other types of samples.

---

### In this section

This section contains the following topics:

Section	See page
5.1.1 The importance of sample preparation	89
5.1.2 Preparing small molecule solutions	90
5.1.3 Preparing macromolecule solutions	91
5.1.4 Calculating cell concentrations	93
5.1.5 Syringe concentration and number of injections	97
5.1.6 Experimental temperature and control heat determination	98
5.1.7 Additional notes	99

---



## 5.1.1 The importance of sample preparation

### Introduction

Isothermal Titration Calorimetry (ITC) is designed to measure the heat of binding when the titrant, also referred to as the ligand, is injected into the sample cell containing the macromolecule sample material. ITC simultaneously determines all binding parameters ( $n$ ,  $K$ ,  $\Delta H$ ,  $\Delta S$ ) in a single experiment.

---

### Minimizing control heat

When the titrant is injected into the cell material and mixed, some additional heat effects other than the binding heat are detectable. The key for successful ITC experiments is to minimize the control heat, thereby allowing the binding heat to be measured more accurately. This control heat will include both the heat of mixing and the heat of dilution. Two primary sources of large control heats are buffer mismatches between the titrant and the macromolecule sample in the sample cell, and a highly concentrated titrant.

---

### Buffer mismatch

The most common mismatch occurs due to pH differences between the titrant and the macromolecule solution, but mismatch could also be a result of salt concentration, or additives such as dioxane, DMSO, glycerol, etc. and the heat of dilution when high concentration of ligand solution from the syringe is injected into the macromolecule solution. The heat of dilution will also be small, but may become large for ligands that form aggregates at higher concentration in the syringe. The most important step in preparing an assay is buffer exchange, which can be achieved by dialysis or by gel filtration.

---

### Concentration determination

Accurate concentration determination is very important when running a calorimetric experiment. Errors will have direct impact on the thermodynamic results. Errors in cell concentration directly affect the stoichiometry, have little effect on enthalpy, and mildly affect affinity. Errors in titrant concentration, on the other hand, directly affect both the stoichiometry and enthalpy, and mildly affect affinity.

---

## 5.1.2 Preparing small molecule solutions

### Introduction

Most small molecule ligands (such as drugs and inhibitors) are supplied in solid form. Solutions can be prepared by dissolving the compound in buffer solution or using organic solvents if the compound has low solubility in buffer solution.

---

### Preparing samples using buffer solution

To prepare samples in buffer solution, follow the steps described below:

Step	Action
1	Prepare the buffer solution using distilled water.
2	Dissolve a known amount of the compound in the buffer solution.
3	Check the pH. If pH of the solution is found to differ from pH of the buffer solution by more than 0.05 units, the pH should be adjusted with a small amount of HCl or NaOH.

---

### Preparing samples using organic solvents

To prepare samples using organic solvents, follow the steps described below:

Step	Action
1	Dissolve the compound in DMSO or some other organic solvent (100 mM or higher).
2	Dilute 50 to 100 fold with buffer.

**Note:**

*Care should be taken to keep the ligand from precipitating when diluted. The concentration of organic additives, such as DMSO, in the final ligand solution should be kept as low as possible (to 1% to 2%, if possible; but no more than 5%) since the macromolecule solution requires addition of the same additive at the same concentration in order to minimize the mismatch heats.*

---

## 5.1.3 Preparing macromolecule solutions

### Introduction

Macromolecule solutions should normally be dialyzed against the buffer solution using a dialysis membrane having the proper molecular weight cut off (MWCO). However, a lyophilized macromolecule sample devoid of salts or additives may be dissolved directly into the buffer, and used without dialysis. The pH of the solution should be checked and adjusted, if necessary. Solid macromolecule samples containing salts and additives, should be dialyzed against the experimental buffer.

---

### Preparing macromolecule solution by dialysis

To prepare a macromolecule solution by dialysis, follow the steps described below:

Step	Action
1	Dialyze the sample at 4°C against a relatively large volume of buffer solution and at least two changes of buffer. The duration of dialysis depends on the sample and buffer, as well as the membrane used.  For example, if glycerol at 10% is added to aqueous buffer solution and a 6 000 to 8 000 MWCO membrane used, it requires at least one overnight dialysis for glycerol to reach concentration equilibrium in the macromolecule solution.
2	Determine the concentration of the macromolecule after dialysis, and remove excessive particles in the solution by filtration or centrifugation.

**Note:**

*Accurate values for binding parameters depend on precise concentration measurements of ligand and macromolecule in the final solutions.*

---

Alternatively, buffer exchange can also be performed using gel filtration. For more information, obtain the technical note, *Rapid sample preparation for MicroCal ITC and DSC experiments using PD MidiTrap G-25 columns (28-9957-23 AA)* at [www.malvern.com/sample prep](http://www.malvern.com/sample prep).

## 5 Performing a run

### 5.1 Preparing the samples

#### 5.1.3 Preparing macromolecule solutions

### Preparing macromolecule solution with an additive

If one of the solutions (e.g., ligand solution) contains an additive such as DMSO, then the same additive at an identical concentration should be added to the other solution (e.g., protein solution) to minimize the heat of mixing. As indicated earlier, the stability of the macromolecule in the presence of the additive should be determined before proceeding. The pH of all final solutions should be checked after additives are added, and matched within 0.05 pH units.

---

## 5.1.4 Calculating cell concentrations

### c-value

ITC is designed to detect the heat that is absorbed (endothermic) or liberated (exothermic) when two solutions containing the binding partners are mixed. The appropriate concentration of the sample material in the sample cell, usually a macromolecule, will depend on the binding affinity, number of binding sites, and heat of binding,  $\Delta H$ . The following equation (Wiseman T. *et al.*, Rapid measurement of binding constants and heats of binding using a new titration calorimeter. *Anal. Biochem.* **179**, 131-137 (1989)) is used when designing ITC experiments to determine the appropriate sample concentration or c value.

$$c = n \cdot M_{\text{tot}} \cdot K_A = \frac{n \cdot M_{\text{tot}}}{K_D}$$

Parameter	Description
c	sample concentration/affinity-related parameter, should lie between 1 and 1000 (preferably 10 to 500 when solubility, availability of material or the sensitivity of the instrument is not limiting)
n	binding stoichiometry (the number of ligand binding sites on the sample molecule)
$M_{\text{tot}}$	molar concentration of sample molecule in the cell
$K_A$	association equilibrium constant
$K_D$	dissociation equilibrium constant

## 5 Performing a run

### 5.1 Preparing the samples

#### 5.1.4 Calculating cell concentrations

## Sample concentration limitations

The figure below depicts simulated curves of the same macromolecular system run at different  $c$ -values.

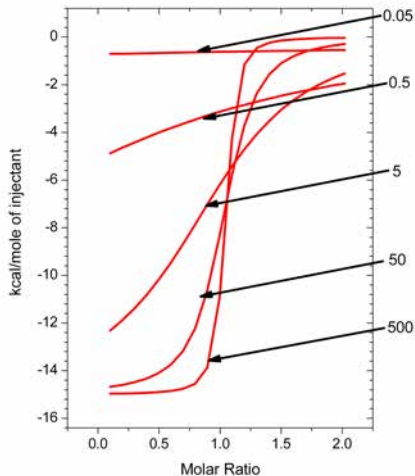

There may be practical limitations that affect the choice of sample concentration:

Experiments including...	should be studied at...
high affinity interactions (low $K_D$ )	low concentrations. (The minimum concentration that will typically cause a confidently measurable heat change for a 1:1 interaction is about 10 $\mu\text{M}$ .)
low affinity interactions (high $K_D$ )	high concentrations. (The concentration that can be used may be limited by availability or solubility of the sample molecule.)

**Note:** *Techniques such as competition experiments or working at high ligand concentration in the case of weak binding can help alleviate these limitations.*

## Affinity determination at different c-values

The affinity is poorly determined at high c-values. At low c-values, one may assume (and fix) a stoichiometry and inject enough titrant to attain a high molar ratio in order to extract both an affinity and a binding enthalpy.

### At high c-values

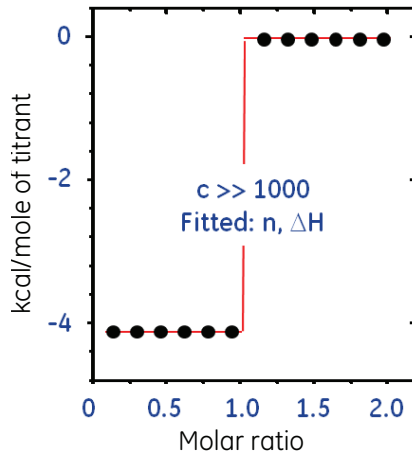

### At medium c-values

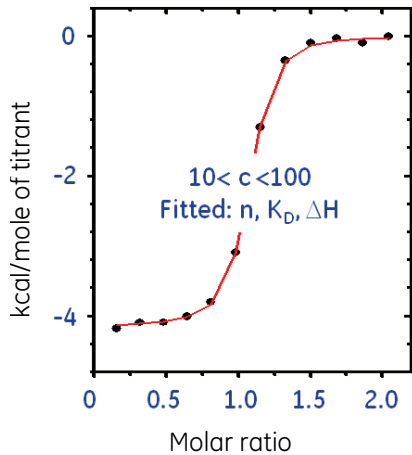

## 5 Performing a run

### 5.1 Preparing the samples

#### 5.1.4 Calculating cell concentrations

#### At low c-values

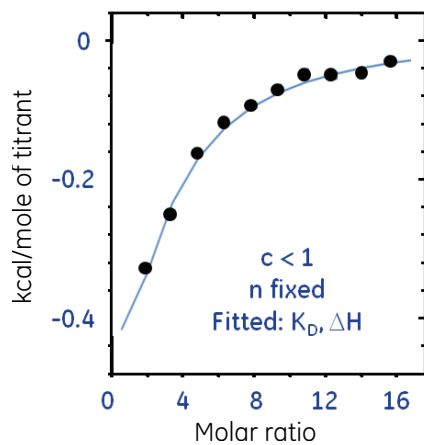



## 5.1.5 Syringe concentration and number of injections

### Calculating syringe concentrations

For a 1:1 binding reaction, the molar concentration of ligand in the injection syringe is typically 10 to 20 times higher than the molar concentration of sample molecule in the cell. This will make sure that the cell material will become saturated or close to saturation by the end of the titration experiment.

**Note:** *Remember, errors in titrant concentration directly affect the stoichiometry, directly affect the enthalpy, and mildly affect affinity.*

---

### Injection number and duration

The specifications for a typical experiment in MicroCal iTC<sub>200</sub> are presented below.

Parameter	Value
Number of injections	19
Injection volume	2 $\mu$ l
Initial injection volume	0.4 $\mu$ l (to minimize the impact of equilibration artifacts sometimes seen with the first injection)  <b>Note:</b> <i>The data point from this initial injection is discarded before data analysis.</i>
Pipette volume	~38 $\mu$ l of ligand solution (sufficient for one typical experiment)

## 5 Performing a run

### 5.1 Preparing the samples

#### 5.1.6 Experimental temperature and control heat determination

## 5.1.6 Experimental temperature and control heat determination

### Experimental temperature

It is most convenient to perform ITC experiments at 25°C to 30°C (i.e., slightly above room temperature) unless other factors dictate differently. Since the cells are passively cooled by heat exchange with the jacket, experiments at low temperature require a longer time for temperature to reach equilibrium before injections can begin.

At high temperatures (above 50°C), the baseline becomes noisier, which has an effect on the quality of data. Other factors that influence the choice of the experimental temperature are the binding affinity and the stability and/or solubility of the ligand or sample molecule. Some solutes, particularly proteins, are not stable above room temperature for long periods of time, and in such cases it may be desirable to work at lower temperatures.

To determine the change in heat capacity,  $\Delta C_p$ , associated with binding, experiments must be performed over a range of temperatures (e.g., 10°C to 40°C) to obtain the temperature dependence of the heat of binding.

---

### Control heat determination

As discussed above, a control experiment is required to determine the heat associated with the dilution of the ligand when it is injected from the syringe into the buffer. This experiment will also include contributions from the injection process itself and any other operational artifacts, which can collectively be thought of as the “instrument blank”. If heat effects for the control run are small and constant, the average heat of injection can be subtracted from the results of the sample run before curve fitting to obtain binding parameters.

However, large heat effects for the control and heat effects that change as the titration proceeds may indicate mismatch between ligand and sample buffer (see *Section 5.1.1 The importance of sample preparation, on page 89*). Buffer matching should then be checked before proceeding with the experiment. If trends in the control results cannot be eliminated by careful buffer matching, they may result from ligand aggregation or self-association in the syringe. More complex evaluation algorithms should be considered in such cases.

---

## 5.1.7 Additional notes

### Reducing agent

It has been found that the presence of DTT (1,4-dithiothreitol) in solution will often cause a drastic shift in ITC baseline as the experiment progresses. If the presence of a reducing agent is required for protein stability, then  $\beta$ -mercaptoethanol (less than 5 mM) or TCEP (Tris[2-carboxyethylphosphine] hydrochloride; less than 2 mM) should be used rather than DTT.

---

### Reverse titration

Most titrations are carried out with the macromolecule solution in the cell and the ligand solution in the syringe. If both binding partners are macromolecules (or both are small molecules) normally the component with multiple binding sites is placed in the cell. However, there are instances where it might be advantageous or even necessary to switch the location of the two components and carry out the reverse titration. If the component, which normally goes in the syringe has low solubility, it may be easier to use that solution in the cell, where its concentration does not need to be nearly as high. If the macromolecule becomes unstable over time in the sample cell, either due to continuous stirring or a high experimental temperature, it may be more stable if placed in the syringe. The solution in the syringe is not stirred or thermostatted at experimental temperature until shortly before it is injected into the cell.

---

## 5.2 Creating a method

### Introduction

This section describes how to create an ITC method in the MicroCal iTC<sub>200</sub> software. An example 19-injection experiment is set up that has 18 injections of 2.0  $\mu\text{l}$  each with 150 s between the injections and one initial, small injection, which is later disregarded to minimize any impact from diffusion during equilibrium of the instrument.

### Creating the method

To create the example method, follow the steps described below:

Step	Action
------	--------

- |   |   |
|---|---|
| 1 | Click on the <b>Advanced Experimental Design</b> tab. |
|---|---|

The screenshot displays the 'Advanced Experimental Design' tab in the MicroCal iTC<sub>200</sub> software. The interface is organized into several sections:

- Experimental Parameters:** Total # Injections (14), Cell Temperature (°C.) (25), Reference Power ( $\mu\text{cal}/\text{sec.}$ ) (0 - 12.25) (11), Initial Delay (sec.) (60), Syringe Concentration (mM) (0.0), Cell Concentration (mM) (0.0), and Stiring Speed (RPM) (1000).
- Injection Parameters:** Volume ( $\mu\text{l}$ ) (0.4), Duration (sec.) (0.8), Spacing (sec.) (150), and Filter Period (sec.) (1).
- Control Options:** Radio buttons for 'All Same', 'Edit Mode', 'Unique', and 'Apply To Rest'.
- Table:** A table with columns 'Volume', 'Duration', 'Spacing', and 'Filter' for 14 injections. All values are consistent: Volume (2.0), Duration (4.0), Spacing (150), and Filter (1).
- Graph:** A plot of NDH (cal/mole) vs Time (s) with a grid. The y-axis ranges from 0.0 to 1.0, and the x-axis ranges from 0.0 to 1.0. An 'Update Experimental Curve' button is located to the right of the graph.

**Step Action**

2 Enter the following **Method Parameters**.

Parameter	Value
<b>Total # Injections</b>	19
<b>Cell Temperature (°C.)</b>	25
<b>Reference Power (µCal/sec.)</b>	10
<b>Initial Delay (sec.)</b>	60
<b>Syringe Concentration (mM)</b>	0.0
<b>Cell Concentration (mM)</b>	0.0
<b>Stirring Speed (RPM)</b>	1000

3 Set the **Feedback Mode/Gain** to **High**.

4 Enter the following parameters for **Injections Setup** with the **All Same** radio button clicked under **Edit Mode**.

Parameter	Value
<b>Volume (µL)</b>	2
<b>Duration (sec.)</b>	4
<b>Spacing (sec.)</b>	150
<b>Filter Period (sec.)</b>	5

5 Change the parameters of the first injection:

- 1 Select the first injection in the table to the right in the **Injection Parameters** workspace.
- 2 Select **Unique** under **Edit Mode**.
- 3 Change the following parameters under **Injection Parameters**:

Parameter	Value
<b>Volume (µL)</b>	0.4
<b>Duration (sec.)</b>	0.8

5 Performing a run  
5.2 Creating a method

Step	Action
6	Click the <b>Save As</b> button and save the method as <code>Training</code> .

## 5.3 Cleaning the cell and syringe before performing an experiment

### Introduction

This section describes different washing procedures for cleaning the cell and syringe before performing an experiment.

**Note:** *Cell and syringe cleanliness are of the utmost importance for obtaining quality data. We recommend performing a **Cell and Syringe Wash** procedure before running experiments. See **Washing Module** control pane, on page 75.*

---

### In this section

This section contains the following topics:

Section	See page
5.3.1 Cell and syringe wash	104
5.3.2 Cell buffer rinse (short)	105
5.3.3 Cell water rinse (long)	106
5.3.4 Detergent soak and rinse (long)	107
5.3.5 Syringe wash (short)	108
5.3.6 Syringe wash (long)	109
5.3.7 Dry syringe	110

---

## 5.3.1 Cell and syringe wash

### Introduction

Use this procedure to perform a quick wash of the cell and the syringe to prepare for an experiment.

- Fluid requirement: Buffer, water, and methanol
  - Time requirement: 9.4 minutes
- 

### Procedure

To perform a quick wash of the cell and the syringe, follow the steps described below:

Step	Action
1	Click <b>Cell and Syringe Wash</b> on the <b>Instrument Controls</b> tab.
2	Follow the instructions on the screen.

---



## 5.3.2 Cell buffer rinse (short)

### Introduction

Use this procedure to rinse the cell with buffer solution before a run.

- Fluid requirement: Buffer
  - Time requirement: 0.8 minutes
- 

### Procedure

To perform a short cell buffer rinse, follow the steps described below:

Step	Action
1	Click <b>Cell Buffer Rinse (Short)</b> on the <b>Instrument Controls</b> tab.
2	Follow the instructions on the screen.

---

## 5.3.3 Cell water rinse (long)

### Introduction

Use this procedure to perform an extended water rinse of the cell.

- Fluid requirement: water
  - Time requirement: 2.5 minutes
- 

### Procedure

To perform a long cell water rinse, follow the steps described below:

Step	Action
1	Click <b>Cell Water Rinse (Long)</b> on the <b>Instrument Controls</b> tab.
2	Follow the instructions on the screen.

---

## 5.3.4 Detergent soak and rinse (long)

### Introduction

Use this procedure to clean the cells to make sure that no contamination exists from previous experiments.

Use this method when a more vigorous cleaning is required for any of the following reasons:

- The system is not operating within its normal performance specifications
- Large baseline drifting is occurring
- Non-repeatable control peaks occur during a water/water test
- An increase in short term noise has occurred

As preventive maintenance, it is also a good idea to do this every few weeks. For heavily used systems, you should consider running this procedure every few days.

MicroCal iTC<sub>200</sub> is manually loaded with detergent according to the online prompts. During the soak, the temperature is set to 50°C for a 20 minute incubation period and then the system cools for 6 minutes. The detergent then has to be manually removed from the MicroCal iTC<sub>200</sub> instrument. After the cell wash tool is inserted, a Cell Water Wash (long) is performed automatically.

- Fluid requirement: water and detergent (manually added to cell)
  - Time requirement: 39 minutes
- 

### Procedure

To perform a long detergent soak and rinse, follow the steps described below:

Step	Action
1	Click <b>Detergent Soak and Rinse (Long)</b> on the <b>Instrument Controls</b> tab.
2	Follow the instructions on the screen.

---

## 5.3.5 Syringe wash (short)

### Introduction

Use this procedure to perform a basic syringe wash only.

- Fluid requirement: water and methanol
  - Time requirement: 10.8 minutes
- 

### Procedure

To perform a short syringe wash, follow the steps described below:

Step	Action
1	Click <b>Syringe Wash (Short)</b> on the <b>Instrument Controls</b> tab.
2	Follow the instructions on the screen.

---

## 5.3.6 Syringe wash (long)

### Introduction

Use this procedure to perform an extended rinse of the syringe.

- Fluid requirement: water and methanol
  - Time requirement: 11.5 minutes
- 

### Procedure

To perform a long syringe wash, follow the steps described below:

Step	Action
1	Click <b>Syringe Wash (Long)</b> on the <b>Instrument Controls</b> tab.
2	Follow the instructions on the screen.

---

## 5.3.7 Dry syringe

### Introduction

Use this procedure to dry the syringe after the syringe has been cleaned manually and left with methanol in it. In this case, the washing module pulls a vacuum through the syringe for several minutes to dry it.

- Fluid requirement: none
  - Time requirement: 5.8 minutes
- 

### Procedure

To perform a dry syringe procedure, follow the steps described below:

Step	Action
1	Click <b>Dry Syringe</b> on the <b>Instrument Controls</b> tab.
2	Follow the instructions on the screen.

---

## 5.4 Loading the samples and performing the experiment

### Introduction

In order to perform a basic ITC titration experiment, the user must load the sample cell and the syringe, enter the desired parameters into the control software, and click **Start**. The reference cell should be filled with water or buffer, and may be left for several days.

**Note:** *Cell and syringe cleanliness are of the utmost importance for obtaining quality data. We recommend performing a **Cell and Syringe Wash** procedure before running experiments. See **Washing Module** control pane, on page 75.*

---

### In this section

This section contains the following topics:

Section	See page
5.4.1 Loading the titration syringe	112
5.4.2 Loading the cell	114
5.4.3 Performing an experiment	115
5.4.4 Procedures after an experiment	116

---

## 5 Performing a run

### 5.4 Loading the samples and performing the experiment

#### 5.4.1 Loading the titration syringe

### 5.4.1 Loading the titration syringe

To load the titration syringe, follow the steps described below:

Step	Action
1	Place a micro centrifuge tube containing approximately 100 $\mu\text{l}$ of the titrant in the tube holder.

**Tip:**

Be sure that the tube sits at the bottom of the holder with the lid fitting into the slot provided (see photo below).





Step	Action
2	<p>Click <b>Syringe Fill</b> on the <b>Instrument Controls</b> tab.</p> <p><i>Result:</i> The software will prompt the user to move the pipette as necessary, and the Washing Module will fill the syringe.</p> <p>Here the onscreen prompts will guide the user through the process. For example, the Fill Port Adaptor (FPA) from the Washing Module may need to be connected to the pipette if it is not still in place after cleaning and drying the syringe).</p> <p><b>Tip:</b> Avoid over-tightening of the FPA, excessive force can damage the titration syringe.</p>



## 5 Performing a run

### 5.4 Loading the samples and performing the experiment

#### 5.4.2 Loading the cell

## 5.4.2 Loading the cell

To load the cell, follow the steps described below:

Step	Action
1	Empty the sample cell of any remaining liquid (left opening) by using the glass Hamilton syringe.
2	Fill the Hamilton syringe with approximately 300 $\mu\text{l}$ of sample. An experiment will be more successful if this sample is close to the experimental temperature, before loading.
3	Remove any air bubbles by gently tapping on syringe glass and pushing excess air out the needle tip.
4	Insert the syringe into the cell and gently touch the bottom with the tip of the syringe needle.
5	Raise the needle tip about 1 mm off the bottom and slowly inject sample solution into the cell until it spills out the top of the cell stem.
6	Finish filling with several small, abrupt spurts of sample to dislodge any bubbles.
7	Lift the tip of the syringe to the point where the cell stem meets the cell port and remove the excess solution.

## 5.4.3 Performing an experiment

To perform an experiment, follow the steps described below:

Step	Action
1	<p>Move the loaded pipette into the cell location and make sure it is seated firmly into the cell port.</p> <p><b>Tip:</b> Make sure that FPA is disconnected from pipette and out of the way by securing it to the wash station (see photo below).</p>



- 2 Insert run parameters in the **Advanced Experimental Design** tab if not already done so (see *Section 5.2 Creating a method, on page 100*).
- 3 Enter file name (see *File naming recommendation, on page 71*).
- 4 Click the **Start** button to begin analysis.



Once a titration run starts, the real-time data is displayed in the **Real Time Plot** tab.

---

- 5 Performing a run
- 5.4 Loading the samples and performing the experiment
- 5.4.4 Procedures after an experiment

## 5.4.4 Procedures after an experiment

After an experiment is performed, follow the steps described below:

- | Step | Action   |
|------|--|
| 1    | Remove the pipette from the cell and place it in the park location to attach the FPA to the syringe. |



- |   |   |
|---|---|
| 2 | Move the pipette and firmly seat into the wash and dry station. |
|---|---|



- |   |   |
|---|---|
| 3 | Insert the cell cleaning module into the sample cell. Be sure to push down until the module is firmly seated. |
|---|---|



Step	Action
4	Click the <b>Cell and Syringe Wash</b> button in the <b>Washing Module</b> control pane of the <b>Instrument Controls</b> tab. The wash module will clean the cell first, followed by a syringe rinse and dry.
5	Remove the cell cleaning module and disconnect the FPA if all experiments are completed.
6	Fill the sample cell with clean, distilled water.
7	It is recommended that the instrument be shut down when not in use ( <b>Power</b> switch in the rear).

# 6 Data analysis using Origin

## Introduction

This chapter describes the data analysis process using Origin software.

Origin, from OriginLab Corporation, is a general purpose, scientific and technical data analysis and plotting tool.

The Origin software used with MicroCal iTC<sub>200</sub> is further enabled and includes routines designed to analyze the ITC data. Most of the ITC routines are implemented as buttons in plot window templates designed specifically for the ITC data analysis software. Some routines are located in the ITC menu in the Origin menu display bar. This tutorial explains how to use all of these ITC routines.

---

## In this chapter

This chapter includes the following sections:

Section	See page
6.1 Basic ITC data analysis and fitting	119
6.2 Adjusting baseline and integration range	136
6.3 Analyzing multiple runs and subtracting reference	143
6.4 ITC data handling	161
6.5 Modifying templates	172
6.6 Advanced curve fitting	181
6.7 Other useful details	248

---

## 6.1 Basic ITC data analysis and fitting

### Introduction

This section describes how to start Origin and its basic menu options. Installation of Origin is described in *Section 3.2 Installing MicroCal iTC<sub>200</sub> software, on page 35*.

This section also describes how to perform routine analysis of ITC data. Origin automatically determines the baseline, the range to integrate the injection peaks, and the initialization of the fitting parameters. These factors can be adjusted manually, as described in the following sections, if the automated data analysis is not adequate. In the case where a single control experiment applies to several runs, the MicroCal Auto-iTC<sub>200</sub> software module is advantageous.

**Note:** *A series of sample ITC files are included with the MicroCal iTC<sub>200</sub> Analysis software. A typical file is designated **RNAHHH.ITC**. This file contains data from a single experiment of 20 injections. It is located at *Origin70\Samples*.*

**Note:** *The **.1** file extension indicates an ITC file generated with the MicroCal data acquisition software. The **.ITC** extension indicates an OMEGA, MCS ITC, VP-ITC, or iTC<sub>200</sub> file generated with the Windows-based version of the MicroCal data acquisition software. The two file types are identical, except that the procedure for opening them differs slightly, as described below.*

---

### In this chapter

This section includes the following topics:

Section	See page
6.1.1 Starting Origin	120
6.1.2 Routine ITC data analysis	121
6.1.3 Creating a final figure for publication	131

## 6.1.1 Starting Origin

To start Origin, follow the steps described below:

Step	Action
------	--------

- |   |   |
|---|---|
| 1 | Double-click the <b>MicroCal Analysis Launcher</b> icon found on the desktop. |
|---|---|



- |   |  |
|---|--|
| 2 | When prompted, select the <b>ITC<sub>200</sub></b> button. |
|---|--|

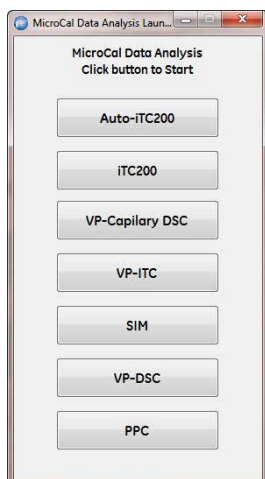



## 6.1.2 Routine ITC data analysis

### Opening the *RNAHHH.ITC* file

To open the *RNAHHH.ITC* file, follow the steps described below:

Step	Action
------	--------

- |   |  |
|---|--|
| 1 | Start Origin for ITC as described in <i>Section 6.1.1 Starting Origin, on page 120</i> .<br><i>Result:</i> The program opens and automatically displays the <b>RawITC</b> plot window. There are several buttons along the left side of the window, which give access to many of the ITC routines. |
|---|--|

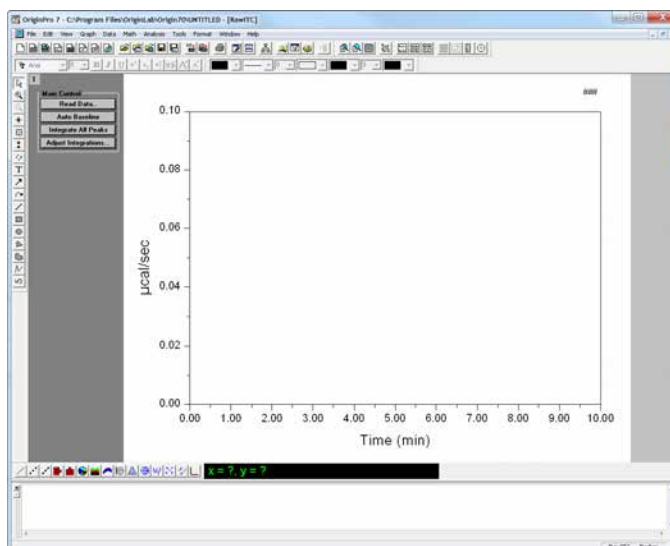

- |   |  |
|---|--|
| 2 | Click <b>Read Data</b> . The <i>Open</i> dialog box opens, with the <i>ITC Data (*.it?)</i> selected as the <i>Files of type</i> : |
|---|--|

**Step**      **Action**

3      Select C:\Origin70\Samples\RNAHHH. ITC from the files list.

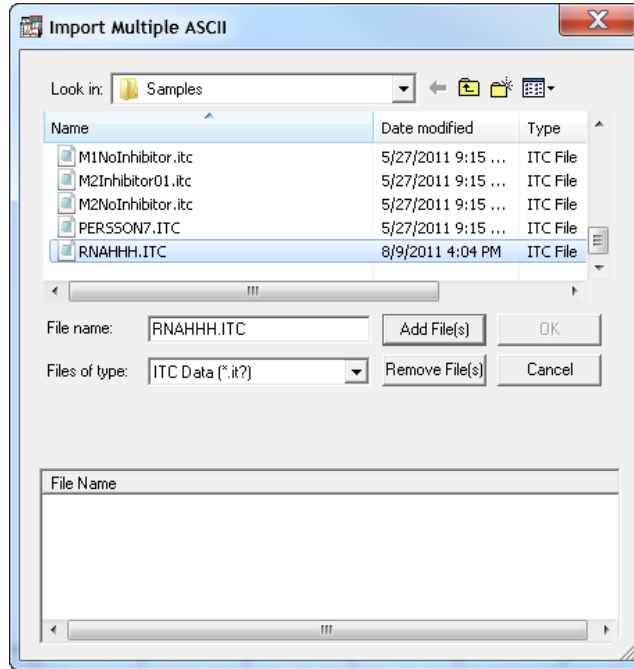

**Note:**

Data file names should not contain any hyphens, periods or spaces.

**Note:**

Origin truncates the file names to the first 15 characters. Therefore, when reading in multiple files, the first 15 characters of the file name must be a unique combination to prevent overwriting the data.

When reading multiple datasets into Origin, the last 10 characters of the file name (excluding the file extension and underscore characters) must be unique and not start with a numeric value. Incorrect naming can be corrected by re-naming the files manually. This only affects the simultaneous analysis of multiple datasets. Single datasets can always be read into Origin. (Examples of good and bad file names, see Examples of good file names:, on page 71 and Examples of bad file names:, on page 71.)

**Tip:**

A default folder for Origin can be selected by navigating to **File:Set Default Folder** and entering the default path (for example, for this tutorial the path can be C:\Origin70\Samples). More information about the files can be viewed by clicking **Details**.

Step	Action
4	<p>Click <b>Add File(s)</b> and then click <b>OK</b>.</p> <p><b>Tip:</b>            The files can also be added by double-clicking on the file name.</p> <p>The default plot window depicts the normalized injection heat as a function of molar ratio in the cell (titrant conc./sample material conc.) in the <b>DeltaH</b> window.</p>

## Data windows

The available windows (i.e., **DeltaH**, **RawITC**, etc.) can be viewed by selecting the **Window** menu list. Alternatively, **ctrl+tab** cycles through the windows.

## Data set worksheets

Origin creates three worksheets to hold the data sets mentioned in the previous section. To open these worksheets refer to *Section 6.4 ITC data handling, on page 161*, which describes how to open worksheets from plotted data, copy and paste data, and export data to an ASCII file.

## Origin data sets

Each time an ITC raw data file series is opened, Origin creates eight data sets. These eight data sets follow a definite naming convention that includes the name of the ITC source file followed by an identifying suffix (injection number is indicated by the row number *i*). Double-click on the layer icon  to view the available data sets :

Data set	Description
<b>Rnahhh_DH</b>	Experimental heat change resulting from injection <i>i</i> , in $\mu\text{cal/injection}$ (not displayed).
<b>Rnahhh_MT</b>	Concentration of macromolecule or sample in the sample cell before each injection <i>i</i> , after correction for volume displacement (not displayed).
<b>Rnahhh_XT</b>	Concentration of injected solute in the sample cell before each injection (not displayed).
<b>Rnahhh_INJV</b>	Volume of injectant added for the injection <i>i</i> .

Data set	Description
<b>Rnahhh_NDH</b>	Normalized heat change for injection <i>i</i> , in calories per mole of injectant added (displayed in <b>DeltaH</b> window).
<b>Rnahhh_XMT</b>	Molar ratio of ligand to macromolecule after injection <i>i</i> .
<b>Rnahhhbase</b>	Baseline for the injection data (displayed in red in the <b>RawITC</b> window).
<b>Rnahhhraw_CP</b>	All of the original injection data (displayed in black in the <b>RawITC</b> window).

**Note:** Two temporary data sets are also created; **Rnahhhbegin** that contains the indices (row numbers) of the beginning of an injection, and **Rnahhhrange** contains the indices of the integration range for the injection.

## Editing concentration values

**Note:** Before fitting a curve to the data, it is recommended to check the current concentration values for the experiment.

To edit concentration values, follow the steps described below:

Step	Action
------	--------

- |   |   |
|---|---|
| 1 | Click the <b>Concentration</b> button located in the <b>Data Control</b> box to the left of the graph, in the <b>DeltaH</b> window. |
|---|---|

*Result:* A dialog box **For Data RNAHHH** opens and displays the concentration values for the current experiment.

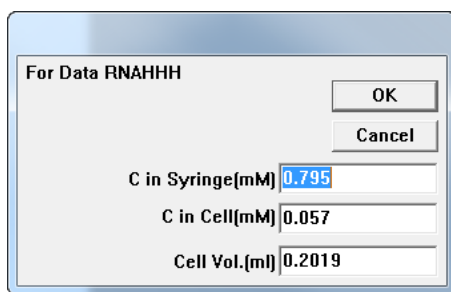

The concentration (**C in Syringe (mM)** and **C in Cell (mM)**) values displayed are those entered by the operator before the experiment starts. Cell volume (**Cell Vol. (ml)**) is constant, which is stored in the data collection software. This value is read by Origin whenever an ITC data file is opened.

Step	Action
------	--------

2	Click <b>OK</b> or <b>Cancel</b> to close the dialog box.
---	---

**Note:**

*Always check that the concentration values are correct for each experiment. Incorrect values will negate the fitting results. The concentration values can be edited by simply entering a new value in the appropriate text box.*

Data can now be fit to a model.

## Model fitting

This section describes the basic procedure for fitting a theoretical curve to the data. See Section 6.6 *Advanced curve fitting, on page 181*, and Appendix A *Equations used for fitting ITC data, on page 310* for a discussion of fitting the equations.

MicroCal iTC<sub>200</sub> Origin provides six built-in curve fitting models, namely:

- **One Set of Sites,**
- **Two Sets of Sites,**
- **Sequential Binding Sites,**
- **Competitive Binding,**
- **Dissociation,** and
- **Enzyme Assays.**

**Note:** *MicroCal iTC<sub>200</sub> software Origin software only contains the **One Set of Sites** and **Two Sets of Sites** models.*

### Fitting the peak area data to the **One Set of Sites** model

To fit the area data to the **One Set of Sites** model, follow the steps described below:

Step	Action
------	--------

1	Click anywhere on the <b>DeltaH</b> plot window to make it the active window or select <b>DeltaH</b> from the <b>Window</b> menu.
---	---

**Note:**

*It is a good practice to make the first injection of 0.4 µl and then remove the first data point from data fitting. This is because during the initial baseline equilibration, the titrant can be diluted by the cell material.*

*The material makes it into the cell but the measured heat is attenuated, so the first integrated injection heat can be inaccurate.*

Bad data points can be deleted from the **DeltaH** window before starting the fitting session.

Step	Action
------	--------

2	Remove the first data point by following the steps below:
---	---

**Note:**

*Notice that the normalized heat is less than expected. This is due to the reason described in step 1, the measured heat of the first injection is attenuated.*

1 Click the **Remove Bad Data** button.

*Result:* The pointer becomes a cross-hair.

2 Click on the first point.

*Result:* A small red cross appears on the selected data point. The XY coordinates, index number, and data set name for the selected point are displayed immediately in the **Data Display Tool** (floating).

3 Press **enter**.

*Result:* The selected data point is deleted. Alternatively, after clicking on **Remove Bad Data**, double-click on a data point to delete it.

**Note:**

*There is no undo command available with which to un-delete a data point.*

It is possible to recover a mistakenly deleted data point by clicking the **Integrate All Peaks** button in the **RawITC** window. All of the injection peaks will re-integrate, and the area data, including the deleted data point, will replot in the **DeltaH** window.

Alternatively, click on the **Concentration** button and then click **OK**.

Even if the concentration has not been changed in the dialog box, Origin goes back to the worksheet and normalizes on the concentration again, which then restores the deleted point.

**Step Action**

3 Click the **One Set of Sites** button.

*Result:* The **NonLinear Curve Fitting: Fitting Session** dialog box opens and displays the initial values for the three fitting parameters for this model - **N**, **K**, and **H**.

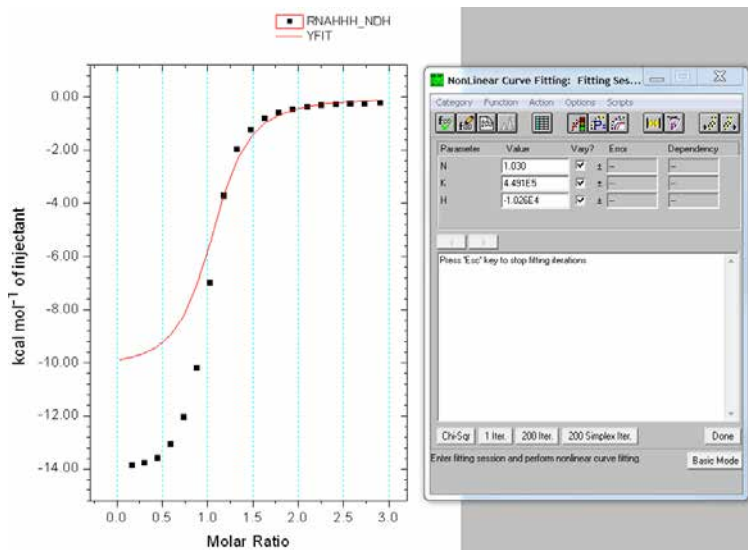

**Note:**

There are two modes of the **NonLinear Curve Fitting: Fitting Session** dialog box, basic and advanced. See Section 6.6 Advanced curve fitting, on page 181, for more information.

Origin initializes the fitting parameters, and plots an initial fit curve (as a straight line, in red) in the **DeltaH** window. Please see Appendix A Equations used for fitting ITC data, on page 310.

4 Click **1 Iter.** or **200 Iter.** button in the **NonLinear Curve Fitting: Fitting Session** dialog box to control the iteration of the fitting cycles.

**1 Iter.** performs a single iteration while **200 Iter.** performs up to 200 iterations.

**Note:**

It may be necessary that the **200 Iter.** command be used more than once before a good fit is achieved.

5 Repeat step 3 until a satisfactory fit is obtained, and Chi<sup>2</sup> is no longer decreasing.

The fitting parameters in the dialog box update to reflect the current fit.

## Fitting parameter constraints

Each fitting model has a unique set of fitting parameters. For the **One Set of Sites** model, these are **N** (number of sites), **K** (binding constant in  $M^{-1}$ ), and  **$\Delta H$**  (heat change in cal/mole). A fourth parameter,  **$\Delta S$**  (entropy change in cal/mole/deg), is calculated from  **$\Delta H$**  and **K** and displayed after fitting. The **NonLinear Curve Fitting: Fitting Session** dialog box can be used to apply mathematical constraints to the fitting parameters. See *Controlling the fitting procedure, on page 185* and *Appendix A Equations used for fitting ITC data, on page 310* for more information.

### Holding a parameter constant

The **Vary?** column in the **NonLinear Curve Fitting: Fitting Session** dialog box contains three checkboxes, one associated with each fitting parameter. If a box is checked, Origin will vary that parameter during the fitting process in order to achieve a better fit. To hold a parameter constant during iterations, uncheck the checkbox.

## Fitting parameters textbox

This section describes how to format and move the textbox and also how to view the results log.

### Copying and pasting the fitting parameters to the **DeltaH** window

To copy and paste the fitting parameters to the **DeltaH** window, follow the steps described below:

Step	Action
------	--------

- |   |   |
|---|---|
| 1 | Click on the <b>Done</b> button in the <b>NonLinear Curve Fitting:Fitting Session</b> dialog box once a good fit is achieved. |
|---|---|

The fitting parameters will be automatically pasted into a text window named **Results Log** and to the **DeltaH** window in a text label. This label is a named object (called **Fit.P**) that is linked to the fitting process through Origin's label control feature.

```
Data: RNAHHH_NDH
Model: OneSites
Chi^2/DoF = 1.164E4
N      0.973 ±0.00346 Sites
K      8.34E5 ±3.78E4 M-1
ΔH     -1.433E4 ±71.75 cal/mol
ΔS     -21.0 cal/mol/deg
```

For more information see *Origin User's Manual* or for online help, right-click anywhere in the text label, select **Label Control** and then press the **F1** key.



**Step Action**

- 2 Position and format this label to achieve the desirable look.  
 The fitting parameters label replaces the **Fit Parameters** label, but retains its position and style when the fitting parameters are pasted. Origin will use any text label named **Fit.P** to display the fitting parameters.
- 3 Click on the label once to select it, select **Format:Label Control**, and enter a name in the **Object Name** text box in the **Label Control** dialog box to re-name the label.
- 4 Right-click anywhere in the text box and select **Properties** item from the drop-down menu.  
 The **Text Control** dialog box appears, which allows formatting the fitting parameters text.

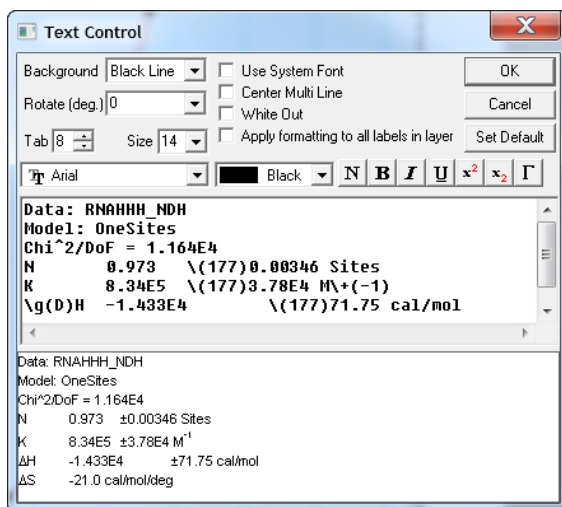

**Text Control dialog box**

The **Text Control** dialog box contains three sections as described below:

Section	Description
Upper section	This section contains various formatting options.
Middle section	This section contains the text box where the desired text, with formatting options, is entered.
Lower section	The lower view box provides a WYSIWYG (What You See Is What You Get) display of the text entered into the middle text box.

## 6 Data analysis using Origin

### 6.1 Basic ITC data analysis and fitting

#### 6.1.2 Routine ITC data analysis

**Tip:** Press the **F1** key while the **Text Control** dialog box is open for online help and a thorough description of the text formatting options.

**Note:** Formatting changes can be saved as part of the **DeltaH** plot window template file. See Section 6.5 Modifying templates, on page 172 for more details.

---

## Viewing the Results Log

### Introduction

Origin automatically routes most analysis and fitting results to the **Results Log** (a sub window of Origin's **Project Explorer**). In most cases, when results are output to the **Results Log**, it opens automatically (although it may be positioned out of view, docked to the lower edge of the workspace). However, it may be necessary to manually open the **Results Log** sometimes.

### Opening the Results Log manually

To manually open (and close) the **Results Log**, navigate to **View:Results Log**.

**Note:** Opening and closing the **Results Log** only controls its view state and does not result in data loss on closing it.

### Docking the Results Log

The **Results Log** is docked to the lower edge of the workspace. It can be docked to any other edge or displayed as a window in the workspace. To prevent the **Results Log** from docking when positioning it as a window, press **ctrl** while dragging.

### Components of the Results Log

Each entry in the **Results Log** includes a date/time stamp, the window name, time stamp, the type of analysis performed, and the results.

---

## 6.1.3 Creating a final figure for publication

### Introduction

This section describes how to edit or modify data to generate a final figure for publication.

---

### Creating a final figure

To create a final figure for publication, select **Final Figure** from the **Analysis** menu. The **ITCFINAL** plot window opens, which contains two related graphs.

Graph	Description
Top graph	The top graph displays raw data in terms of $\mu\text{cal}/\text{sec}$ plotted against <b>Time (min)</b> , after the integration baseline has been subtracted.
Bottom graph	The bottom graph displays the normalized integration data in terms of <b>kcal/mole of injectant</b> plotted against <b>Molar Ratio</b> .

**Note:** *The two x-axes are linked, so that the integrated area for each peak appears directly below the corresponding peak in the raw data.*

## 6 Data analysis using Origin

### 6.1 Basic ITC data analysis and fitting

#### 6.1.3 Creating a final figure for publication

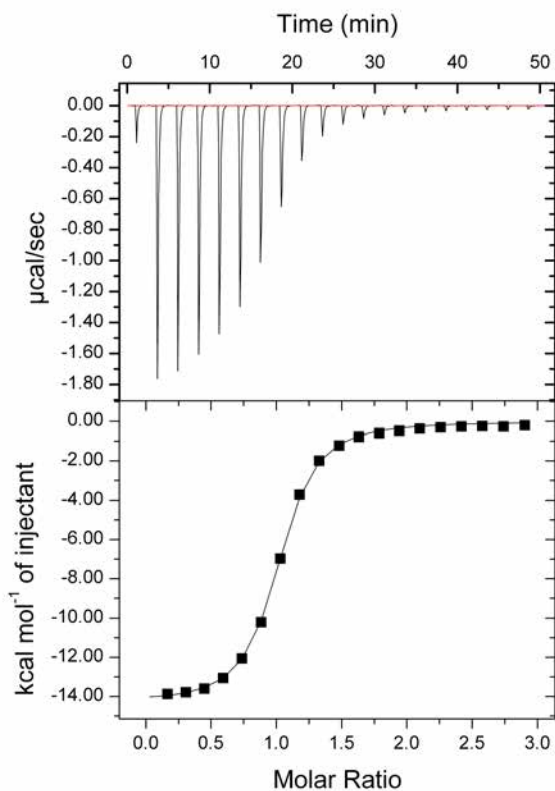

---

### Updating the final figure

If the integration data or the fit curve in the **DeltaH** window, or the raw data in the **RawITC** window has been modified, select **Final Figure** again to update the **ITCFINAL** window with the changes.

---

### Removing the baseline from the raw data

The top graph in the **ITCFINAL** window still includes the integration baseline at  $Y = 0$ . The baseline can be removed before printing the graph.

To remove the baseline from the raw data, follow the steps described below:

**Step Action**

- 1 Double-click on the baseline. The **Plot Details** dialog box opens.

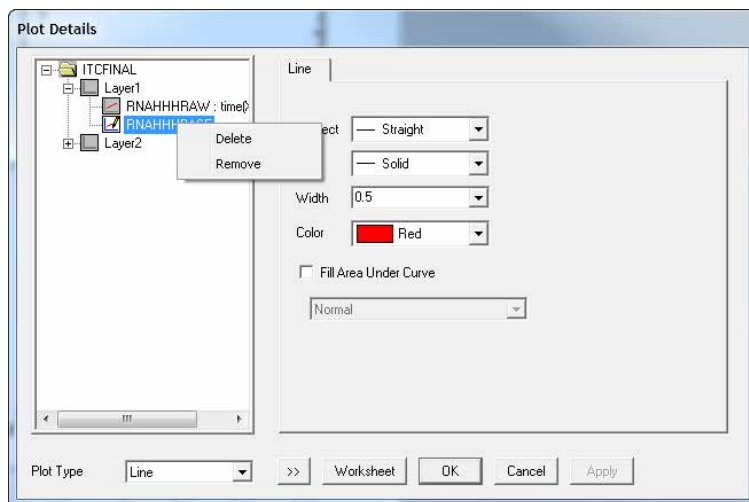

- 2 Right-click on the **RNAHHHBASE** data name in the **Layer 1** folder and click **Remove**.

The baseline data are removed from the project.

**Note:**

*The baseline can also be removed from the plotted data, by double-clicking on the **Layer Control** button in the upper left corner of the **ITCFINAL** window, and then moving the **RNAHHHBASE** data from the **Layer Contents** list to the **Available Data** list by first highlighting it and then selecting the left-pointing arrow.*

## Pasting the fitting parameters to the **ITCFINAL** window

To paste the fitting parameters to the **ITCFINAL** window, follow the steps described below:

**Step Action**

- 1 Click on the **DeltaH** window, or select **DeltaH** from the **Window** menu. **DeltaH** becomes the active window.
- 2 Click on the fitting parameters text label in the upper-left corner of the window.  
 A colored selection square surrounds the text.

## 6 Data analysis using Origin

### 6.1 Basic ITC data analysis and fitting

#### 6.1.3 Creating a final figure for publication

- | Step | Action   |
|------|--|
| 3    | Select the <b>Edit:Copy</b> command.   |
| 4    | Click on the <b>ITCFINAL</b> window, or select <b>ITCFINAL</b> from the <b>Window</b> menu. <b>ITCFINAL</b> becomes the active window. Click once on a position in the graph where the parameter box should appear.  |
| 5    | Select the <b>Edit:Paste</b> command. The fitting parameters are pasted to the <b>ITCFINAL</b> window.   |
| 6    | To position the text label next to the integration data, size of the label needs to be reduced first. Right-click inside the text box then select <b>Properties...</b> from the drop-down menu to open the <b>Text Control</b> dialog box. Select <b>10</b> (or type 10) in the <b>Size</b> drop-down list to reduce the point size to <b>8</b> . Click <b>OK</b> to close the dialog box. |
| 7    | Click and drag the label to position it next to the integration data, as shown below.  |

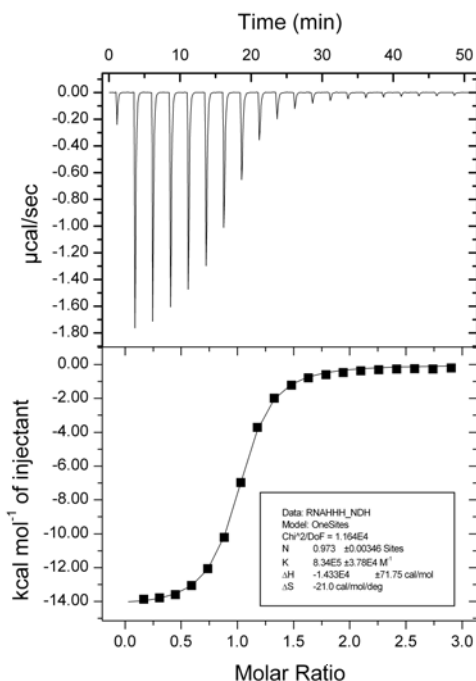

## Printing the final figure

To print the page in the **ITCFINAL** window, follow the steps described below:

Step	Action
1	Make sure that <b>ITCFINAL</b> window is the active window.
2	Select <b>File:Print</b> .

## Saving the project and exit

To save the project and exit, follow the steps described below:

Step	Action
1	Choose <b>File: Save Project As...</b> The file <b>Save As</b> dialog box opens.
2	Enter a name for the project, for example <code>Lesson 1</code> , in the <b>File Name</b> text box.  <b>Note:</b> <i>The name for the project may contain up to 255 characters and include spaces.</i>
3	Click the <b>Save</b> button. The entire contents of this project (including all data sets and plot windows) are saved into a file called <b>Lesson 1.OPJ</b> .
4	Select <b>File:Exit</b> to close Origin.

## 6.2 Adjusting baseline and integration range

### Introduction

In routine data analysis, integration details (baselines and integration ranges) are determined automatically. However, sometimes the automatically determined values are not sufficiently accurate, and the integration details need to be set manually. This is especially true when working with very small injection peaks. This section describes how to manually set the integration details.

---

### Entering the *Adjust Integrations* session

To enter the **Adjust Integrations** session, follow the steps described below:

Step	Action
1	Start Origin as described in <i>Section 6.1.1 Starting Origin, on page 120</i> .
2	Open the <b>RNAHHH.ITC</b> file as described in <i>Section 6.1 Basic ITC data analysis and fitting, on page 119</i> .  Raw data are plotted in the <b>RawITC</b> window. Normalized area data are plotted in the <b>DeltaH</b> window.
3	Navigate to <b>Window:File:RawITC</b> .  <b>Note:</b> <i>The <b>RawITC</b> window or any active window can lose its formatting instructions if in <b>Draft View</b> mode. Change to <b>Page View</b> mode to restore the formatting instructions.</i>
4	Click the <b>Adjust Integrations</b> button in the <b>RawITC</b> window.  The cursor changes into a cross hair.



Step	Action
5	<p>Move the cursor into the <b>Raw/ITC</b> plot window and click on or near the injection peak to be adjusted.</p> <p>For example, click on peak <b>19</b> (second peak from the right). The window zooms in on the baseline region of peaks <b>18, 19</b> and <b>20</b>.</p> <p><b>Note:</b> <i>Origin will show the injection peak before and after the chosen injection, but any manipulations will only affect the integrated area between the center injection.</i></p> <p>A new set of buttons appears along the top edge of the window. Also, Two blue lines appear denoting the integration range.</p>

## Adjusting the integration details

### Introduction

The baseline adjustment tool displays the raw data as a black line, the fitted baseline as a red line, and two vertical blue lines. The leftmost blue line denotes the start of the region to be integrated. The rightmost blue line denotes the end of the region to be integrated. Everything to the right of the rightmost blue line is defined as baseline. Each injection has a range defined as baseline. These regions are fit, as a whole, to yield the red baseline. Moving the rightmost blue line affects how well the baseline fits the raw data, and/or which data are integrated as heat.

### Adjusting the integration details

To adjust integration details, follow these steps, which will also be described later in detail below (see *Adjusting the baseline*, on page 139):

**Note:** *Some steps negate the other steps, so the order in which these steps are followed is important.*

Step	Action
1	Adjust all the baseline ranges of applicable peaks using the rightmost vertical blue line.
2	Click the <b>Recalculate Baseline</b> button.

Step	Action
------	--------

3	Adjust all the integration ranges of applicable peaks using the rightmost vertical blue line, again.
---	--

**Note:**

Do not click the **Recalculate Baseline** button.

Also, move individual baseline points, if necessary, after selecting an injection peak by clicking the **Move Baseline Points** button.

4	Quit the session and click the <b>Integrate All Peaks</b> button.
---	---

The figure below shows the expanded view of the screen:

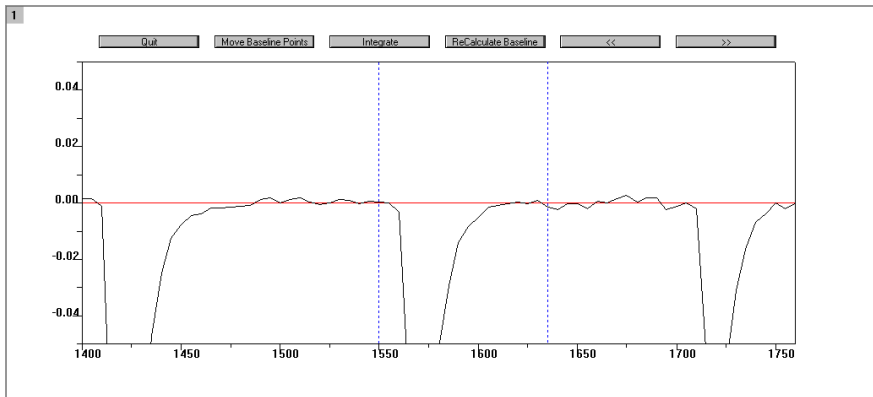

## Integrating the selected peak

To integrate the selected peak, click on the **Integrate** button.

This integrates the peak, using the current baseline and integration range. The curve in the **DeltaH** window is updated accordingly. The integration results are also updated on the worksheet containing the injection data.

## Selecting another peak

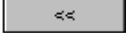
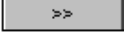
To select another peak, click on the  and  buttons to move to the previous or next peak respectively.

**Note:** The current peak number is always displayed in the window title bar.

## Ending the *Adjust Integrations* session

To end the **Adjust Integrations** session, click the **Quit** button.

The **RawITC** window is restored to show all of the injection peaks. The area data in the **DeltaH** window is also updated to reflect any changes that have been made.

---

## Integrating all peaks

Click the **Integrate All Peaks** button in the **RawITC** template to subtract the current baseline, integrate all injection peaks and replot the area data.

**Note:** Clicking the **Auto Baseline** button will revert to the original baseline, negating any baseline adjustments.

---

## Adjusting the baseline

### Altering the baseline range

To alter the baseline range, follow the steps described below:

Step	Action
1	Select a peak.  The vertical blue lines only apply to the current peak. The region between the blue lines is integrated. The remaining portion of the injection, to the right of the rightmost blue line is defined as a baseline. Because the red, fitted baseline is fit to the baseline region of each injection, the fit can be defined by simply dragging the rightmost blue line to either the right or the left. For example, if an experimental artifact (i.e., bubble spike) is confined to the baseline region, the baseline fit may be adversely affected. Reposition the rightmost blue line to the right of the spike.
2	Click the <b>Recalculate Baseline</b> button to improve the baseline fit.  The spike will now be integrated, but that will taken care of in a later step.  <b>Note:</b> <i>It is recommended that these baseline range adjustments be completed before moving on, because clicking the <b>Recalculate Baseline</b> button will negate the later steps.</i>

---

### Altering the integration range





**Note:** Altering the integration range and making fine adjustments using the **Move Baseline Points** button may be done at the same time. However, clicking the **Recalculate Baseline** button negates these steps.

To alter the integration range, follow the steps described below:

Step	Action
1	Move the rightmost blue line so that it includes only what is to be integrated. For example, as described in step 2 above, to avoid integrating the bubble spike, simply reposition the blue line to the left of the spike.
2	Click the <b>Integrate</b> button. This depicts the integrated region.
3	Repeat for all applicable injections.

### Making fine adjustments to the baseline

To make finer adjustments to the baseline, follow the steps described below:

Step	Action
1	Click the <b>Move Baseline Points</b> button in the <b>Adjust - Peak 11</b> window. The automatically generated points for this baseline are displayed. For the baseline, Origin displays 15 points, which include the central peak and each neighboring peak. In most cases adjusting only the central five points for the central peak of interest is sufficient. The outermost points are usually more closely associated with the neighboring peaks.
2	Click on a point, then drag the mouse or use the  and  keys to move the point (note that baseline points can only move vertically). Use the  and  keys (or the mouse) to select the next point to the right or left. Repeat for each point to be moved.

**Note:**

*When any point on the baseline is moved, the position of the moved point automatically becomes part of the baseline and any future integration will be calculated from this new baseline.*

3	Press the <b>Esc</b> (escape) key (or the <b>enter</b> key) to set the baseline. The data points will disappear and the cursor will change from the cross hair to the pointer tool so that the integration range can be adjusted. If the integration range is already set, click the <b>Integrate</b> button and click on an arrow key to show an adjacent peak.
---	--

**Note:**

*Clicking the **Recalculate Baseline** button after making fine adjustments will negate the fine adjustments and will simply refit according to the position of the vertical blue lines.*

### Expanding the baseline portion

To expand the flat baseline portion of the data, follow the steps described below:

- | Step | Action   |
|------|--|
| 1    | Click on the magnifying glass icon in the <b>Toolbox</b> . Drag to zoom to a user-specified region.  |
| 2    | Double-click on the magnifying glass icon to return to the original non-expanded display or proceed to integrate the next peak.              |
| 3    | Double-click on the y-axis to bring up the <b>Y Axis</b> dialog box to maintain the same expanded y-axis limits for integrating other peaks. |

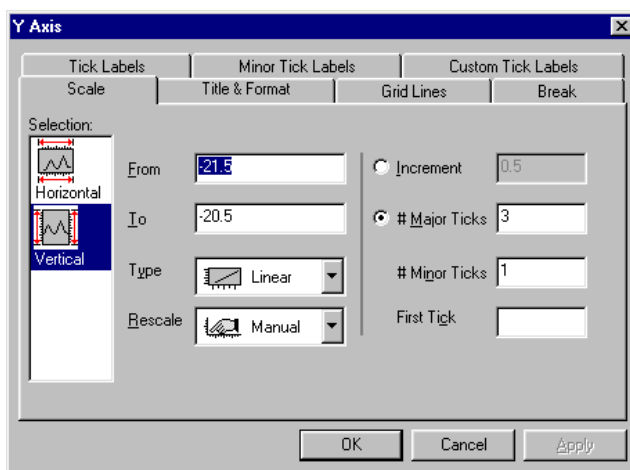

- |   |  |
|---|--|
| 4 | Click on the <b>Scale</b> tab in the lower left corner of the dialog box, change the <b>Rescale</b> option from <b>Normal</b> to <b>Manual</b> and click <b>OK</b> .<br>The y-axis maintains these limits and does not rescale when adjusting integration for other peaks. |
|---|--|

### Viewing the worksheet data

To view the worksheet data, follow the steps described below:

- | Step | Action  |
|------|---|
| 1    | Select the pointer tool  by clicking on it in the toolbox. |

**Step**      **Action**

- 2      Double-click anywhere on the trace of the **RawITC** data plot in the plot window or select **Format:Plot**.  
The **Plot Details** dialog box opens for this data plot.

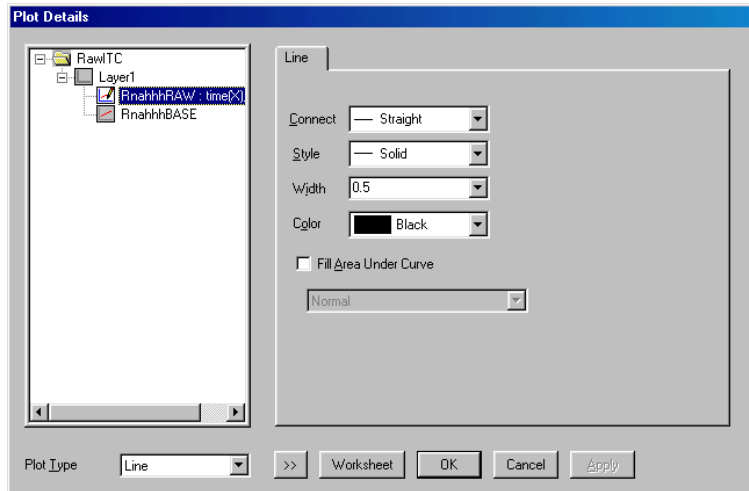

- 3      Click on the **Worksheet** button.  
The worksheet containing the injection data opens.

**Note:**

*The worksheet x-axis values are in seconds, while the plotted data is shown in minutes. This is because the x-axis has been factored, as described in Section 6.5 Modifying templates, on page 172.*

## After adjusting integrations

After adjusting the integrations, proceed to fit the data as described in *Section 6.1 Basic ITC data analysis and fitting, on page 119.*

## 6.3 Analyzing multiple runs and subtracting reference

### Introduction

Origin allows multiple runs of ITC data to be opened into the same project. The heat of ligand dilution into buffer can thus be subtracted from the reaction heat by performing the control experiment and subtracting this reference data from the reaction heat data.

In order to subtract the reference injections, both the sample and reference area data should be available in the controller memory. This section describes how to read two data files into Origin and to subtract one from the other. It also illustrates some helpful procedures for dealing with difficult data.

**Note:** *Before beginning this section, open a new project by selecting **File:New:Project**, to clear any old data that may be in memory.*

---

### In this section

This section contains the following topics:

Section	See page
6.3.1 Opening multiple data files	144
6.3.2 Adjusting the molar ratio	150
6.3.3 Subtracting reference data	152

---

## 6.3.1 Opening multiple data files

### Introduction

In the following example, two area (.itc) data files will be opened and subtracted from one another.

### Reading sample data into memory

To read the sample data into the controller memory, follow the steps described below:

- | Step | Action  |
|------|---|
| 1    | Click on the <b>Read Data...</b> button in the <b>RawITC</b> plot window.<br>The <b>Import Multiple ASCII</b> dialog box opens. |
| 2    | Click on the down arrow in the <b>Files of type:</b> drop-down list box and select <b>ITC Data (*.it?)</b> .                    |
| 3    | Navigate to <code>c:\Origin70\Samples</code> .  |

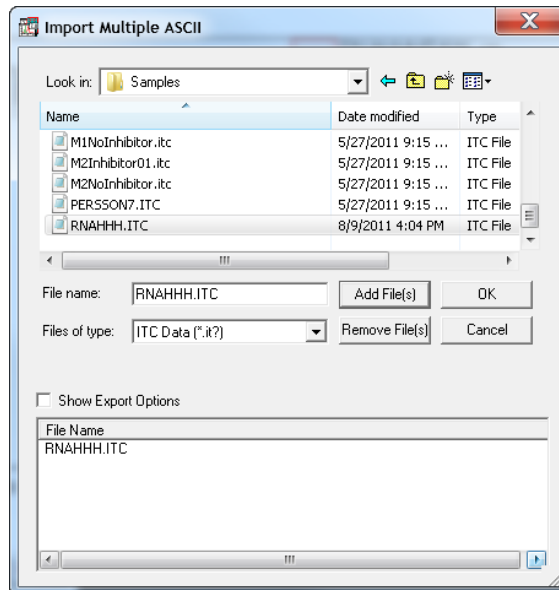



**Step**      **Action**

- 4 Double-click on **RNAHHH.ITC**. Alternatively, single click on **RNAHHH.ITC** and click the **Add File(s)** button. Click **OK**.

The RNAHHH.ITC file opens and the data are normalized on concentration. This data is then plotted in the **DeltaH** window, as a scatter plot called **RNAHHH\_NDH**. **RNAHHH\_NDH** shows area data as kcal/mole of injectant plotted against Molar Ratio. Remove the first data point by clicking on the **Remove Bad Data** button, selecting the first data point, and pressing **enter**.

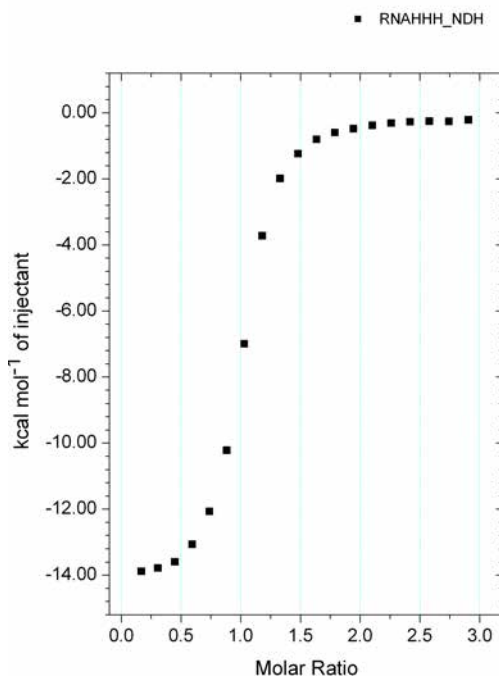

Step	Action
------	--------

- |   |   |
|---|---|
| 5 | Return to the <b>RawITC</b> template and repeat the above steps to open the reference data file <b>BUFFER.ITC</b> . <b>BUFFER.ITC</b> is also located in the <b>Samples</b> subfolder.<br>A new plot, <b>BUFFER_NDH</b> , replaces <b>RNAHHH_NDH</b> in the <b>DeltaH</b> window. |
|---|---|

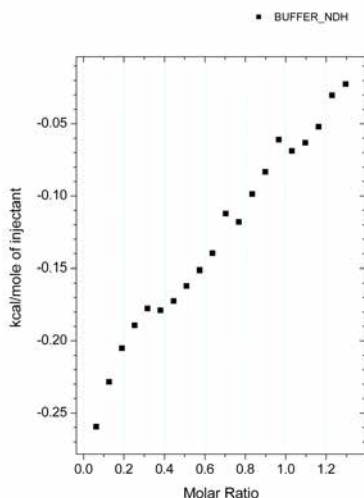

**Note:**

When the second ITC data file **BUFFER\_NDH** is opened, the **RNAHHH\_NDH** data are cleared from the **DeltaH** plot window. The **RNAHHH\_NDH** data are not deleted from the project, but are simply removed from the window display.

## Showing both the sample and reference area data

To show both the sample and the reference area data, follow the steps described below:

Step	Action
------	--------

- |   |  |
|---|--|
| 1 | Double-click on the layer 1 icon  , at the top left corner of the <b>DeltaH</b> window.<br>The <b>Layer Control</b> dialog box opens. |
|---|--|

- | Step | Action  |
|------|---|
| 2    | Click on <b><i>rnahhh_ndh</i></b> in the <b>Available Data</b> list, then click on the => button. <b><i>rnahhh_ndh</i></b> is copied to the <b>Layer Contents</b> list. Be sure to have <b>Rescale on OK</b> checked. |

**Note:**  
*It is not checked by default.*

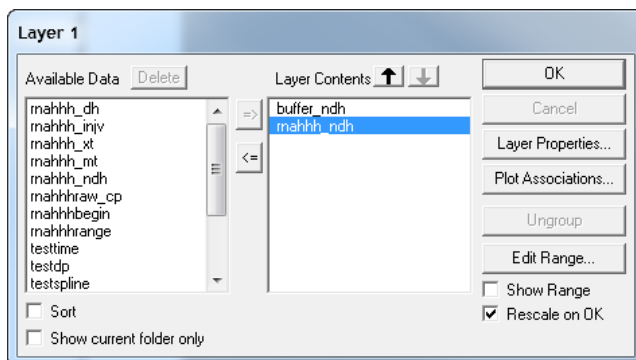

## 6 Data analysis using Origin

### 6.3 Analyzing multiple runs and subtracting reference

#### 6.3.1 Opening multiple data files

Step	Action
------	--------

3	Click <b>OK</b> .
---	-------------------

**RNAHHH\_NDH** plots into the **DeltaH** window. The axes automatically rescale to show all of the data.

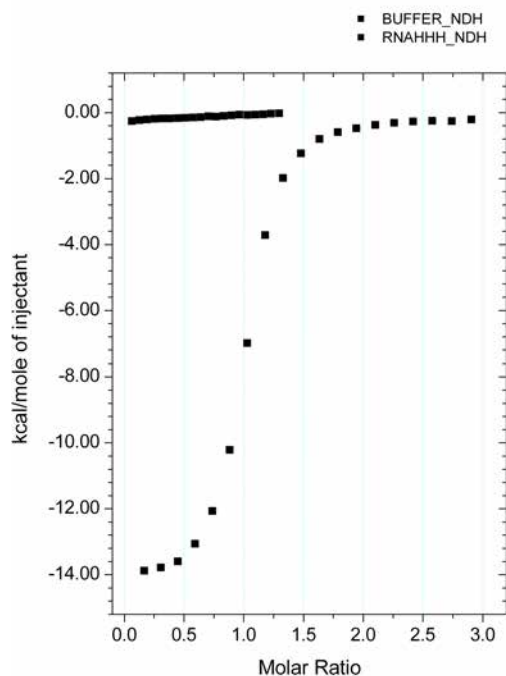

**Note:**

The **Available Data** list in the **Layer Control** dialog box shows all data sets currently available for plotting in this project. The **Layer Contents** list shows all data sets currently plotted in the active layer. See *Origin User's Manual* or *Origin's online Help* menu item (or press **F1**) for more information on handling Origin data.

## Editing data files

Any number of data files can be read into the same **DeltaH** window. When multiple data plots appear in the same window, the active data plot can be set by clicking on the plot

type (line/symbol) icons next to the data set name in the legend: 

A red border around the line/symbol icon indicates the currently active data plot. Editing, fitting, and other operations can only be carried out on the active plot.

---

## 6.3.2 Adjusting the molar ratio

### Introduction

Origin automatically assigns a concentration of 1.0 mM in order to obtain non-infinite values for the molar ratio to allow plotting of the **BUFFER\_NDH** points. Before subtracting the reference data, check that the molar ratio is identical for both data sets. This will ensure that the final result is accurate, and that the two data sets plot in register (that is, injection #1 of the control experiment plots at the same molar ratio as injection #1 of the sample experiment, and so on).

**Note:** The **BUFFER\_NDH** data plots from molar ratio 0 to ca. 1.3, while the **RNAHHH\_NDH** data plots from 0 to ca. 2.0. In the case of the **BUFFER\_NDH** data, the molar ratio is, in fact, infinity since injections of 21.16 mM ligand solution were made into a cell, which contained only buffer and no macromolecule (i.e., in order to determine heats of dilution of ligand into buffer).

### Adjusting the molar ratio

To adjust the molar ratio, follow the steps described below:

- | Step | Action   |
|------|--|
| 1    | Click on the <b>Data</b> menu, and check that <b>RNAHHH: XMt(X), NDH(Y)</b> is checked. If not, select <b>RNAHHH: XMt(X), NDH(Y)</b> from the menu.<br>Alternatively, click on the <b>RNAHHH_NDH</b> listing in the plot type icon in the legend.<br>RNAHHH is set as the active data set. |

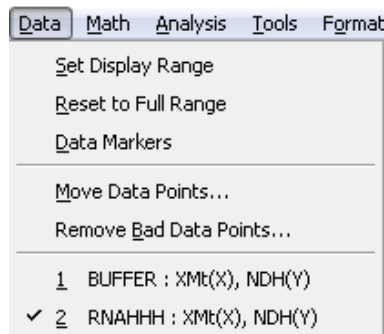

- |   |  |
|---|--|
| 2 | Click the <b>Concentration</b> button in the <b>DeltaH</b> window.<br>Note the value in the <b>C in Cell (mM)</b> field (it should be 0.057) in the dialog box that opens. |
|---|--|

- | Step | Action  |
|------|---|
| 3    | Click <b>Cancel</b> to close the dialog box.  |
| 4    | Repeat step 1, but this time set the <b>Buffer: XMt(X), NDH(Y)</b> data set as active.  |
| 5    | In the <b>DeltaH</b> window, click the <b>Concentration</b> button again.<br>A dialog box displays the concentration values for buffer. |
| 6    | Enter 0.057 in the <b>C in Cell (mM)</b> field.   |
| 7    | Click <b>OK</b> .   |
- The two data sets will now plot in register, as shown below:

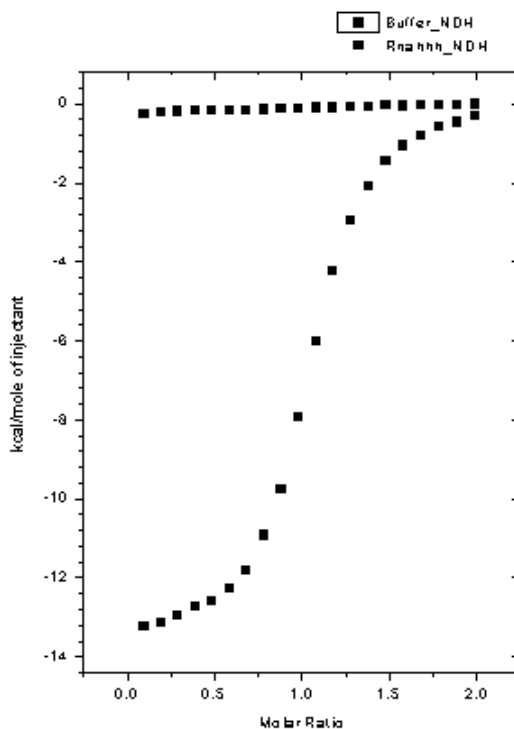

## 6.3.3 Subtracting reference data

### Subtracting reference data

There are several ways to subtract the control heat of **BUFFER\_NDH** from that of **RNAHHH\_NDH**.

**Note:** Select the method that best suits the application.

#### Option1: Subtracting a constant

To subtract a constant from **RNAHHH\_NDH**, for example, the mean value of **BUFFER\_NDH**, follow the steps described below:

Step	Action
------	--------

- |   |  |
|---|--|
| 1 | Open the area data worksheet by double-clicking on any data point of the <b>BUFFER.ITC</b> data set while in the <b>DeltaH</b> window. This opens the <b>Plot Details</b> window. Click the <b>Worksheet</b> button. |
|---|--|

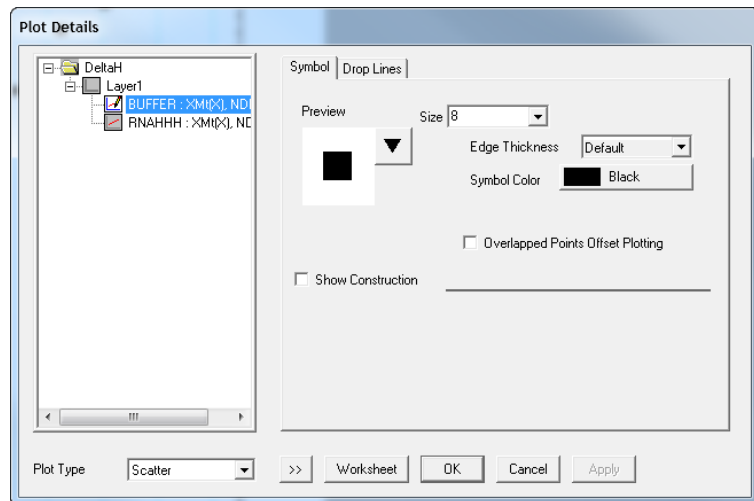

- |   |  |
|---|--|
| 2 | Select the <b>NDH</b> column by clicking on the column heading. All the cells of the column will be highlighted. |
|---|--|



**Step Action**

3

Navigate to the **Statistics on Column(s)** button 

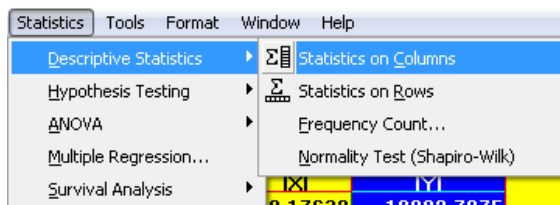

A new worksheet appears with the mean, standard deviation, standard error of the mean, the sum of the data and the number of data points of the **NDH** dataset column.

	sd(yErz)	se(yErz)	Min(Y)	Inim(Y)	Max(Y)	Imax(Y)	Range(Y)	Sum(Y)	N(Y)
1	42.75661	12.34335	277.41502	10	429.41935	8	151.00433	4217.97962	

4

Select **Math:Simple Math**.

The **Math on/between Data Set** dialog box opens.

5

Select **RNAHHH\_NDH** from the **Available Data** list, then click on the upper-most => button.

**RNAHHH\_NDH** is copied to the **Y1** text box. **RNAHHH\_NDH** also appears next to **Y**. **Y**: indicates the name of the data set into which the resulting data will be copied.

6

Click in the **operator** box, and type **-** in the text box.

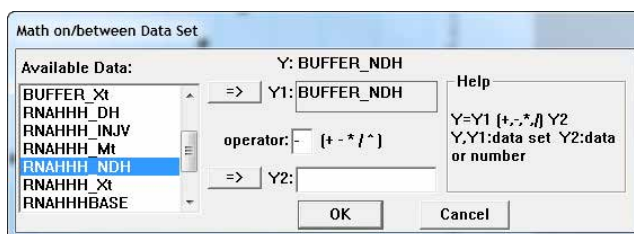

7

Click in the **Y2** text box and enter the mean value from step 3 above, at the insertion point.

8

Click **OK**.

The constant is subtracted from each value in the **RNAHHH\_NDH** data set. The result is plotted as **RNAHHH\_NDH** in the **DeltaH** window.

### Option2: Fitting a constant

This option does not utilize an actual control dataset. Instead, during the fitting process described in *Section 6.1 Basic ITC data analysis and fitting, on page 119*, navigate to **Math:Simple Math** and subtract constants from **RNAHHH.NDH** until the discrepancy between the fitted model and the dataset is minimized.

To fit a constant, follow the steps described below:

Step	Action
1	Once the data set to be fit is active, click the <b>One Set of Sites</b> button. Click <b>200 Iter.</b> until the desirable solution is obtained.
2	Select <b>Math: Simple Math</b> from the menu bar.
3	Subtract (or add) a constant as described above in Option 1.
4	Click the <b>200 Iter.</b> button again and observe whether the Chi-sqr increases or decreases.
5	Repeat step 2 until the Chi-sqr is adequately minimized.

### Option3: Subtracting a line

To subtract a straight line from **RNAHHH\_NDH**, follow the steps described below:

Step	Action
1	Click on the pointer tool  to deselect the screen reader tool.
2	Check the <b>Data</b> menu to see that <b>BUFFER : XMt(X), NDH(Y)</b> is the active data set (the active data set will be check marked). All editing, and fitting operations are carried out on the active data set. Select <b>BUFFER : XMt(X), NDH(Y)</b> if it is not active.

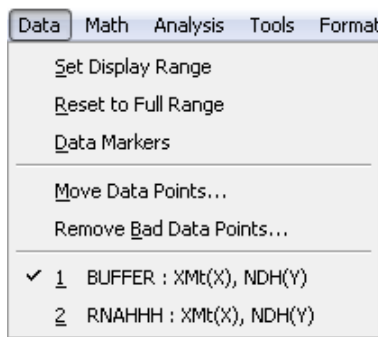

**Step Action**

- 3 Select **Linear Regression** from the **Math** menu.  
 A straight line is fit to the **Buffer** data. Origin assigns the name **LinearFit1\_bufferNDH** to the data set for this line.

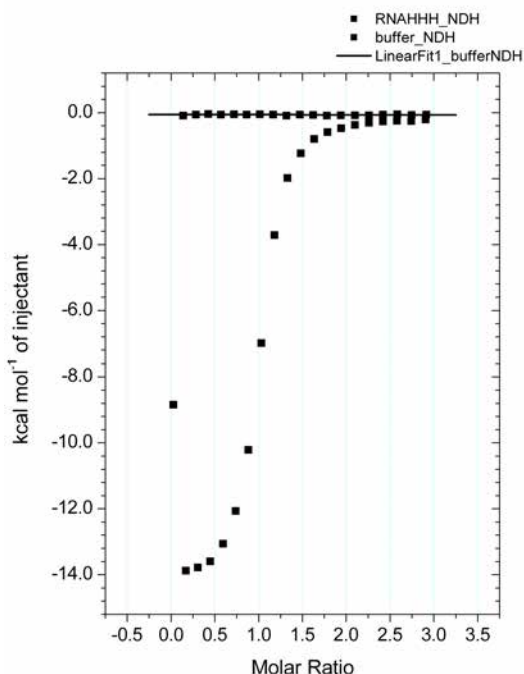

- 4 Select **Simple Math** from the **Math** menu.  
 The **Math** dialog box opens.
- 5 Select **RNAHHH\_NDH** from the **Available Data** list, then click on the uppermost => button.  
**RNAHHH\_NDH** is copied to the **Y1** text box.
- 6 Select **LinearFit1\_bufferNDH** from the **Available Data** list, then click on the lowermost => button.  
**LinearFit1\_bufferNDH** is copied to the **Y2** text box.

**Step**      **Action**

7              Click in the **operator** box and type **-**.

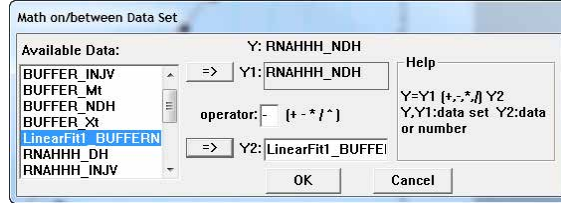

8              Click **OK**.

Every point in **LinearFit1\_bufferNDH** is subtracted from the corresponding point in **RNAHHH\_NDH**. The resulting data set is plotted as **RNAHHH\_NDH** in the **DeltaH** plot window.

**Note:**

The **BUFFER\_NDH** reference data plot (the original twelve injection points) is not affected.

**Tip:**        To make the difference in injection time spacing between **RNAHHHRAW\_CP** and **BUFFERRAW\_CP** more apparent, plot both raw data sets in the same plot window.

**Option 4: Point-by-point**

**Step**      **Action**

1              Click on the **Subtract Reference Data..** button in the **DeltaH** window.

The **Subtract Reference Data** dialog box opens. The most recent file opened, in this case **Buffer\_NDH**, appears in both the **Data** and **Reference** drop-down list box.

**Note:**

The data set in the **Reference** box is subtracted from the data set in the **Data** box.

Step	Action
------	--------

- |   |  |
|---|--|
| 2 | Select <b>Rnahhh_NDH</b> from the <b>Data</b> drop down list.<br><b>Rnahhh_NDH</b> is highlighted and entered as the data. |
|---|--|

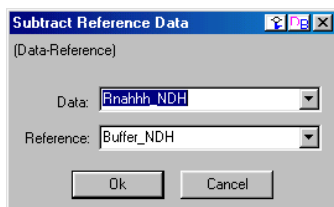

- |   |   |
|---|---|
| 3 | Click <b>OK</b> .<br>Every point in <b>Buffer_NDH</b> is subtracted from the corresponding point in <b>Rnahhh_NDH</b> . The result is plotted as <b>Rnahhh_NDH</b> in the active layer, in this case layer 1, in the <b>DeltaH</b> plot window. |
|---|---|

**Note:**

**BUFFER\_NDH** is not affected by this operation. It is cleared from the **DeltaH** window, but is still listed as available data in the **Layer Control** dialog box. The original **RNAHHH\_NDH** data could be recovered by selecting **Math : Simple Math** and adding the **BUFFER\_NDH** data set to the new **RNAHHH\_NDH** data set.

## Saving the project and all related data files

To save the project and all related data files, follow the steps described below:

Step	Action
------	--------

- |   |  |
|---|--|
| 1 | Select the <b>File:Save Project As</b> command from the Origin menu bar.<br>The <b>Save As</b> dialog box opens, with <b>untitled</b> selected as the file name. |
|---|--|

## 6 Data analysis using Origin

### 6.3 Analyzing multiple runs and subtracting reference

#### 6.3.3 Subtracting reference data

Step	Action
2	<p>Enter a new name for the project, navigate to the folder in which to save the file, and click <b>OK</b>.</p> <p><b>Tip:</b> Origin7.0 accepts long file names.</p> <p><b>Note:</b> <i>It is not necessary to enter the .opj file extension. This will be added automatically. The file can now be accessed by selecting <b>File:Save Project</b> command.</i></p> <p><b>Tip:</b> Delete the original injection data to save some memory space. This may be useful when reading a large number of data sets into the same Origin project.</p>

## Deleting a data set from a project

To delete a data set from a project, follow the steps described below:

Step	Action
1	Double-click on any layer icon  in the plot window .
2	Select a data set from the <b>Available Data</b> list, then click the <b>Delete</b> button.

Alternatively, a data set from a project can also be deleted as described below:

Step	Action
1	Double-click on the trace of the data plot to be deleted in the plot window. The <b>Plot Details</b> dialog box opens. The name of the data set appears in the <b>File List</b> box under the layer icon.
2	Right-click on the file name to be deleted and then click <b>Delete</b> .

**Note:** *In either case, the data set along with any related data plots is deleted from the project. However, any data set saved to disk will not be affected.*

## Displacing overlapping data sets

Whenever multiple data sets are included in the same plot, data points from the different data sets may overlap. There are two ways to eliminate this overlap by displacing one or more of the curves on the y-axis.

---

## Displacing data sets

A data set can be displaced by selecting **Math:Simple Math** and adding or subtracting a constant from all points in one data set to displace it.

Alternatively, a data set can be displaced by following the steps described below:

Step	Action
1	Make the appropriate data set active by selecting it in the list for plot type icons.
2	Select <b>Math:Y Translate</b> .
3	Use the resulting cross-hair icon to select one data point in the active set, click on it, and press <b>enter</b> (or double-click on a data point).
4	Move the icon to the <b>Y position</b> on the graph where the point should be after displacement, click on it and press <b>enter</b> . The entire data set will be translated on the y-axis by that amount.

---

## Plotting both *rnahhraw\_cp* and *bufferraw\_cp* in the *RawITC* plot window

To plot both *rnahhraw\_cp* and *bufferraw\_cp* in the *RawITC* plot window, follow the steps described below:

Step	Action
1	Click on the <b>RawITC</b> window to make it active (or select <b>RawITC</b> from the <b>Window</b> menu).
2	Double-click on the layer 1 icon  in the <b>RawITC</b> window. The <b>Layer 1</b> dialog box opens.

**Step**      **Action**

- 3      Select **rnahhhraw\_cp** in the **Available Data** list, then click the => button. **rnahhhraw\_cp** is added to the **Layer Contents** list.

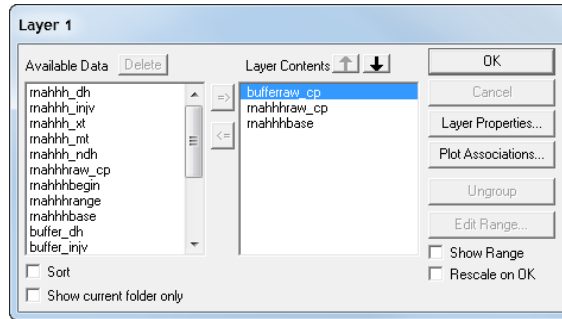

- 4      Click **OK**.  
Both RNAHHHRAW\_cp and bufferRAW\_cp are now plotted in the **RawITC** window. Note the difference in the time spacing of the injections.

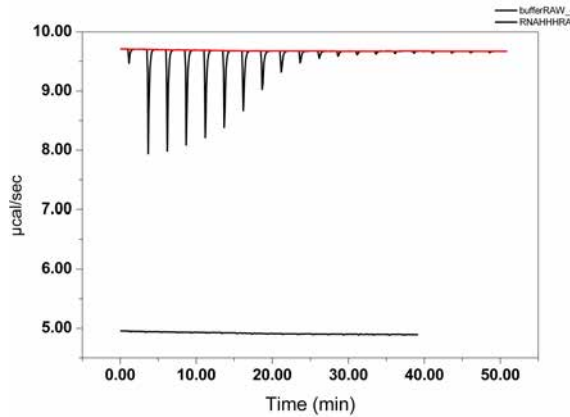

**Note:**

*The difference in peak spacing is not a problem when subtracting reference data. Data files having different time spacing can still be accessed, since only the integration area data for each peak is important.*



## 6.4 ITC data handling

### Introduction

Every data plot in Origin has an associated worksheet. The worksheet contains the X, Y and, if appropriate, the error bar values for the plot. A worksheet can contain values for more than one data plot.

It is always possible to view the worksheet from which data were plotted. This section describes how to open the worksheet associated with a particular data plot, copy/paste the data, export the data to an ASCII file, and import ASCII data.

---

## 6 Data analysis using Origin

### 6.4 ITC data handling

#### 6.4.1 Reading worksheet values from plotted data

## 6.4.1 Reading worksheet values from plotted data

To read worksheet values from plotted data, follow the steps described below:

Step	Action
1	Select <b>File:New:Project</b> . A new Origin project opens to display the <b>RawITC</b> plot window.
2	Click on the <b>Read Data...</b> button. The <b>File Open</b> dialog box opens, with the <b>ITC Data (*.it?)</b> file name extension selected. <b>Note:</b> <i>If a default folder has not been set previously, navigate to the C:\Origin70\Samples folder.</i>
3	Select <b>Rnahhh</b> from the file name list, and click <b>OK</b> . Origin plots the <b>Rnahhh</b> data as a line graph in the <b>RawITC</b> plot window, automatically creates a baseline, integrates the peaks, normalizes the integration data, and plots the normalized data in the <b>DeltaH</b> plot window. As a result, the eight data sets are created.

## Data sets

The eight data sets created by Origin are described below:

Data set	Description
<b>Rnahhh_DH</b>	Experimental heat change resulting from injection <i>i</i> , in $\mu\text{cal}/\text{injection}$ (not displayed).
<b>Rnahhh_MT</b>	Concentration of macromolecule in the cell before each injection <i>i</i> , after correction for volume displacement (not displayed).
<b>Rnahhh_XT</b>	Concentration of injected solute in the cell before each injection (not displayed).
<b>Rnahhh_INJV</b>	Volume of injectant added for the injection <i>i</i> .
<b>Rnahhh_NDH</b>	Normalized heat change for injection <i>i</i> , in calories per mole of injectant added (displayed in <b>DeltaH</b> window).
<b>Rnahhh_XMT</b>	Molar ratio of ligand to macromolecule after injection <i>i</i> (X value of data point).

Data set	Description
<b>Rnahhhbase</b>	Baseline for the injection data (displayed in red in the <b>RawITC</b> window).
<b>Rnahhhraw_CP</b>	All of the original injection data (displayed in black in the <b>RawITC</b> window).

**Note:** An Origin data set is named after its worksheet and worksheet column, usually separated by an underscore. Thus, the first six data sets above will all be found on the same worksheet (**RNAHHH**), in columns named **DH**, **INJV**, **Xt**, **Mt**, **XMt** and **NDH**, respectively.

## Temporary data sets

In addition to the above eight data sets, Origin also creates the following two temporary data sets:

Temporary data set	Description
<b>Rnahhhbegin</b>	Contains the indices (row numbers) of the start of an injection.
<b>Rnahhhrange</b>	Contains the indices of the integration range for the injections.

**Note:** The two temporary data sets are located on separate worksheets, named **rnahhhbase** (an Origin created baseline) and **RnahhhRAW** (the experimental data). The temporary data sets are indices created by Origin and do not have a worksheet created.

## Saving area data to a separate file

To save area data to a separate file, follow the steps described below:

Step	Action
1	Select <b>Window:DeltaH</b> . Alternatively, press and hold the <b>ctrl</b> key and press the <b>tab</b> key to scroll through Origin's open windows, until <b>DeltaH</b> window is active.

## 6 Data analysis using Origin

### 6.4 ITC data handling

#### 6.4.1 Reading worksheet values from plotted data

Step	Action
2	Click the <b>Save Area Data</b> button located in the <b>Data Control</b> box to the left of the graph. Origin opens the <b>File Save As</b> dialog box, with <b>Rnahhh.DH</b> selected in the <b>File name</b> text box.
3	Select a folder for the file and click <b>OK</b> .

## Opening the RNAHHH worksheet

To open the **RNAHHH** worksheet, follow the steps described below:

Step	Action
1	Select the <b>Plot...</b> command from the <b>Format</b> menu. The <b>Plot Details</b> dialog box opens for the <b>RNAHHH_NDH</b> data plot (if the <b>DeltaH</b> window is active).

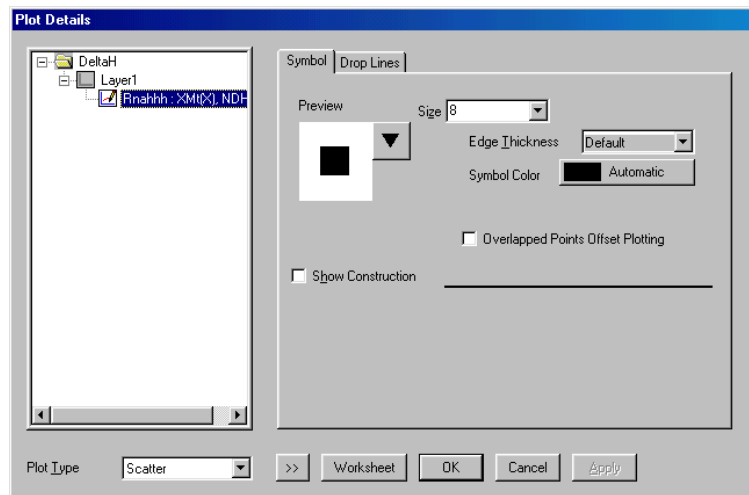

Step	Action
------	--------

2	Click on the <b>Worksheet</b> button.
---	---------------------------------------

The **RNAHHH** worksheet opens.

**Note:**

If a worksheet cell is not wide enough to display the entire number, Origin fills the cell with ##### signs. To view the full number, increase the column width, by placing the cursor on the left or right border of the column name, waiting till the cursor changes to a double headed arrow, then moving the column edge to the right to increase the column width. Alternatively, right-click the column name select **Properties** from the drop-down list and increase the value in the **Column Width** text box.

	DH	INJV	Xt	Mt	XMt	NDH
1	-2.81295	0.4	0	0.057	0.02766	-8781.48457
2	-22.06078	2	0.00157	0.05689	0.16678	-13810.23052
3	-21.9174	2	0.00939	0.05633	0.30727	-13719.83842
4	-21.61066	2	0.01714	0.05577	0.44912	-13526.70782
5	-20.77464	2	0.0248	0.05522	0.59235	-13000.69854
6	-19.1915	2	0.03239	0.05468	0.73694	-12004.79162
7	-16.23101	2	0.0399	0.05414	0.8829	-10142.63231
8	-11.10665	2	0.04733	0.0536	1.03023	-6919.54202
9	-5.90742	2	0.05468	0.05307	1.17893	-3649.36542
10	-3.15596	2	0.06195	0.05255	1.329	-1918.66421
11	-1.9587	2	0.06915	0.05203	1.48044	-1165.43904
12	-1.27078	2	0.07627	0.05152	1.63324	-732.55785
13	-0.9473	2	0.08331	0.05101	1.78742	-528.8822
14	-0.75312	2	0.09027	0.0505	1.94296	-406.52075
15	-0.60205	2	0.09716	0.05	2.09987	-311.27525
16	-0.48763	2	0.10396	0.04951	2.25815	-239.07266
17	-0.42211	2	0.11069	0.04902	2.4178	-197.62411
18	-0.396	2	0.11734	0.04853	2.57882	-180.96459
19	-0.41661	2	0.12391	0.04805	2.7412	-193.68106
20	-0.32861	2	0.13041	0.04757	2.90496	-138.09007
21			0.13682	0.0471		
22						

## 6.4.2 Copy and paste worksheet data

### Introduction

Data can be copied from a worksheet to the clipboard, then pasted from the clipboard into another Origin worksheet, a plot window, or another Windows-based application.

---

### Selecting a range of worksheet values

To select a range of worksheet values, follow the steps described below:

Selection object	Action
A cell	Click on the cell.
An entire row	Click on the row number.
An entire column	Click on the column heading.
A contiguous portion of worksheet values	<p>Click on the first cell, row or column, keep the mouse button depressed, drag to the final cell, row, or column that should be included in the selection range, then release the mouse button.</p> <p><b>Note:</b> <i>To select a range of cells where the initial cell but not the final cell is in view, click on the first cell and scroll to the final cell, press and hold the <b>shift</b> key and then click the final cell.</i></p>

### Copying the selected values to the clipboard

To copy the selected values to the clipboard, select **Copy** from the **Edit** menu. Alternatively, right-click inside the highlighted text and select **Copy** from the menu.

---

## Selecting a destination for the copied values

To select a destination for the copied values, follow one of the steps described below:

Destination	Action
A plot window	Click on the plot window to make it active.
A worksheet	Click on the worksheet (or select <b>File:New:Worksheet</b> to open a new worksheet), then click to select a single cell.  This cell will be in the upper left corner of the destination range.
Another Windows-based application	Switch to the target application, then follow the pasting procedure for that application.

## Pasting the copied values from the clipboard to the destination

To paste the copied values from the clipboard to the destination, select **Paste** from the **Edit** menu.

Alternatively, right-click and select **Paste**.

	A[X]	B[Y]
1	0.09681	#####
2	0.19391	#####
3	0.29129	-12967.3443
4	0.38896	#####
5	0.48692	#####
6	0.58517	#####
7	0.6837	#####
8	0.78252	#####
9	0.88163	-9748.91693
10	0.98103	-7922.79781
11	1.08072	-6013.36964
12	1.18069	-4256.64162

**Note:** *It may happen that the worksheet does not show the data, but only displays pound signs. The data is available for manipulations but is not displayed because the column is not wide enough. Increase the column width by placing the cursor at the right edge of the column header (the cursor changes into a double headed arrow) then clicking and dragging the cursor to the right. Alternatively right-click the column heading, select **Properties**, then increase the number for the column width.*

## 6.4.3 Exporting worksheet data

### Introduction

The contents of any worksheet can be saved into an ASCII file. This section describes how to open the worksheet for the **RnahhhBASE** baseline data plotted in the **RawITC** window, and export the X and Y data to an ASCII file.

---

### Opening the **RnahhhBASE** worksheet

To open the **RnahhhBASE** worksheet, follow the steps described below:

Step	Action
1	Click on the <b>RawITC</b> window (or choose <b>RawITC</b> from the <b>Window</b> menu) to make it the active window.
2	Select <b>2 RnahhhBASE</b> from the <b>Data</b> menu. <b>2 RnahhhBASE</b> is checkmarked to show it is selected.

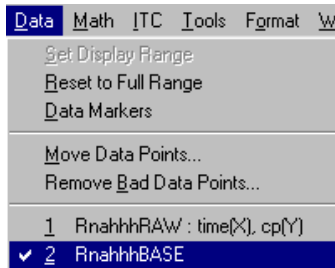

3	Select <b>Plot...</b> from the <b>Format</b> menu. The <b>Plot Details</b> dialog box opens.
---	---



Step	Action
------	--------

- |   |  |
|---|--|
| 4 | Click the <b>Worksheet</b> button.<br>The <b>RnahhhBASE</b> worksheet opens. |
|---|--|

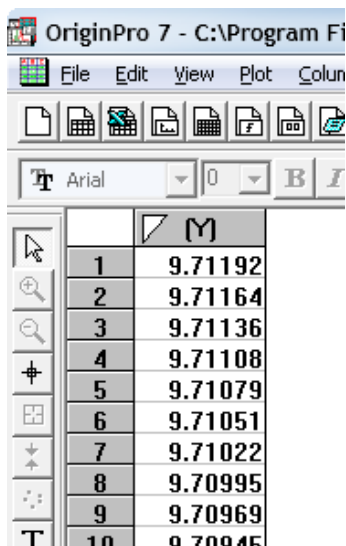

## Exporting the worksheet data as an ASCII file

To export the worksheet data as an ASCII file, follow the steps described below:

Step	Action
------	--------

- |   |   |
|---|---|
| 1 | Select <b>Export ASCII...</b> from the <b>File</b> menu.<br>The <b>Export ASCII</b> dialog box opens, with <b>RnahhhBASE.DAT</b> selected as the file name. |
|---|---|

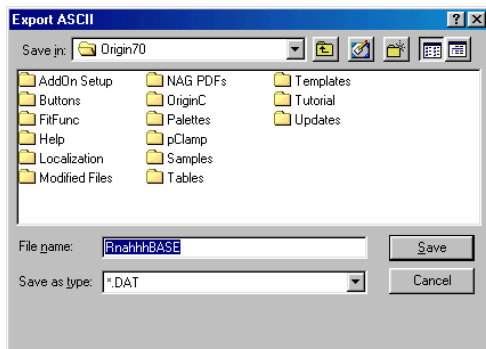

- |   |  |
|---|--|
| 2 | Click <b>Save</b> .<br>The <b>ASCII Export into RnahhhBASE.DAT</b> dialog box opens. |
|---|--|

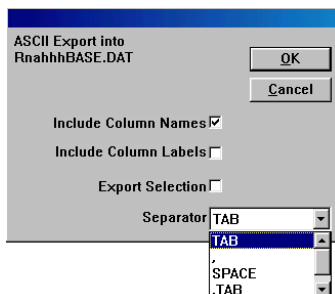

**Note:**

The output of this ASCII file can be formatted (Please refer to the Origin User's Manual for more information about exporting worksheet data). This file may then be opened into any application that recognizes ASCII text files.

## 6.4.4 Importing worksheet data

### Introduction

ASCII files can be imported directly into an Origin worksheet or plot window. Origin menu supports a number of additional file formats for importing data (Lotus™, Microsoft Excel™, dBASE™, LabTech™, etc.) while the menus for ITC or DSC data analysis support routine ASCII files.

---

### Importing an ASCII file into a new worksheet

To import an ASCII file into a new worksheet, follow the steps described below:

Step	Action
1	Navigate to <b>File:New:Worksheet</b> . A new Origin worksheet, <b>Data1</b> , opens.
2	Select the <b>File:Import:ASCII</b> command. Alternatively, <b>File:ASCII:Options</b> can also be selected to set ASCII file import options. The <b>Import ASCII</b> dialog box opens, set to open a data file with a <b>.DAT</b> extension.
3	Double-click on a file in the <b>File Name</b> list (for example, the <b>RnahhhBASE.DAT</b> file that has just been exported). The <b>RnahhhBASE</b> data is imported into the worksheet.

---

### Importing an ASCII data file into a plot window

To import an ASCII data file into a plot window, follow the steps described below:

Step	Action
1	Navigate to <b>File:New:Graph</b> .
2	Select <b>Import ASCII:Single File</b> from the <b>File</b> menu.
3	Select the <b>RnahhhBASE.dat</b> ASCII file from the <b>Files</b> list. Enter the appropriate <b>Initial X Value</b> (0 for <b>RnahhhBASE.dat</b> ) and <b>Increment in X</b> (28 . 25287).
4	Click <b>OK</b> .

---

## 6.5 Modifying templates

### Introduction

The template files of Origin can be changed. This section describes how to edit both, the **DeltaH** and **ITCFinal** plot windows and save the changes into the corresponding template file. Though the changes made will be minor, any property of a template can be changed. For more information about customizing templates, refer to the *Origin User's Manual* or press the **F1** key for online help.

**Note:** *In this section, modifications in the plot window templates that are basic to Origin's operation will be performed. In the unlikely event that a mistake is made, which cannot be corrected, simply copy the original template file from the **Custom** folder of the installation CD-ROM. This will correct any problem that may arise.*

---

### Template files in Origin

The **RawITC**, **DeltaH**, and **ITCFinal** plot windows (and all other plot windows in Origin) are created from template files (\*.OTP file extension). A template file contains all of the attributes of a plot window (or a worksheet) except the data. The important thing about template files is that a plot window can be changed, and the changes saved into the template file for that window. The next time this window is opened, it will include the changes. Thus, template files allow customization of plot windows to meet the specifications.

---

## 6.5.1 Modifying the *DeltaH* template

### *DeltaH* template

The *DeltaH* template shows units of *kcal/mole of injectant* along the left y-axis. The scale for this axis is actually defined in terms of cal/mole of injectant, but the axis is factored by 1000 to yield units of kcal/mole.

The right y-axis labels for the *DeltaH* template are hidden from view. In the following example, the template will be modified so that the right y-axis labels are visible. These labels will then be factored by 1000 so that they are identical to the left y-axis labels, and the changes saved into the *DeltaH* template file.

---

### Opening the *DeltaH* plot window

To open the *DeltaH* plot window, follow the steps described below:

Step	Action
1	Click on the <b>New Project</b> button from the <b>Standard</b> toolbar or navigate to <b>File:New:Project</b> to create a new project.
2	Click on the <b>Read Data...</b> button in the <b>RawITC</b> window. The <b>File Open</b> dialog box opens, with the <b>ITC Data (*.ITC)</b> file extension selected.

## 6 Data analysis using Origin

### 6.5 Modifying templates

#### 6.5.1 Modifying the *DeltaH* template

Step	Action
------	--------

- |   |   |
|---|---|
| 3 | Navigate to the C:\Origin70\Samples folder and open any ITC data file (for example, <i>Buffer.ITC</i> ). The <i>DeltaH</i> template opens to show the normalized area data. |
|---|---|

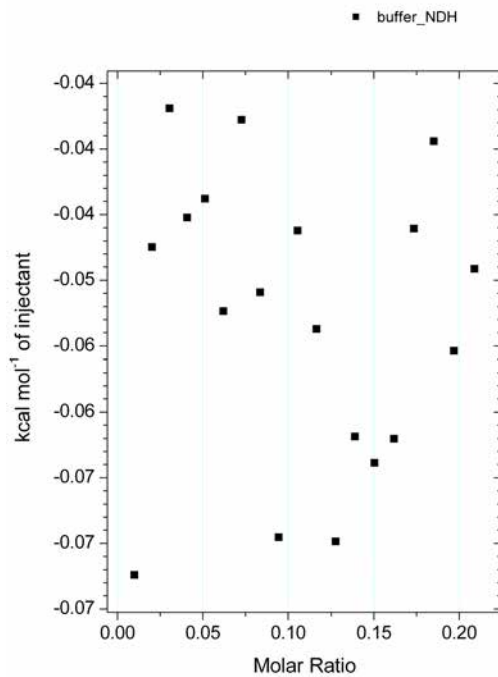

## Changing the axes properties

To change the axes properties, follow the steps described below:

Step	Action
------	--------

- |   |   |
|---|---|
| 1 | Double-click either axes' labels in the <i>DeltaH</i> window. Alternatively, select <b>Format:Axes:Y Axis</b> . |
|---|---|

The **Y Axis - Layer 1** dialog box opens.

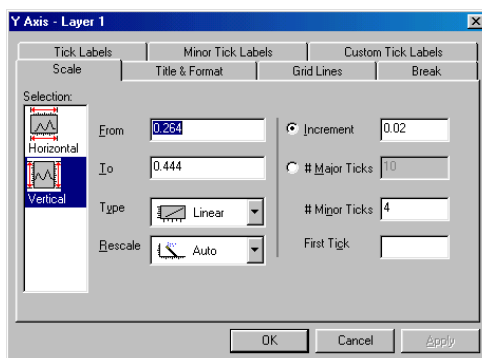

- |   |   |
|---|---|
| 2 | Click on the <b>Tick Labels</b> tab.                    |
| 3 | Select <b>Left</b> from the <b>Selection:</b> list box. |

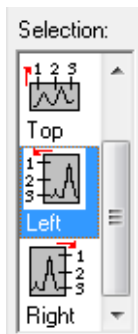

- |   |   |
|---|---|
| 4 | Change the font value from 22 to 20. Do the same for the x-axis (bottom).     |
| 5 | Click <b>OK</b> .<br>The dialog box closes. The <i>DeltaH</i> window redraws. |

## Saving changes into the *DeltaH* template file

To save the changes into the *DeltaH* template file, follow the steps described below:

Step	Action
1	Select <b>File:SaveTemplate As...</b> Origin opens a dialog box asking if the file should be saved as <b>DELTAH.OTP</b> (the <i>DeltaH</i> template file).
2	Click <b>Cancel</b> to cancel changing the original <i>DeltaH</i> template. Click <b>OK</b> to save the modified <i>DeltaH</i> window as <b>DELTAH.OTP</b> .
<b>Tip:</b>	<i>If the modified template has been saved, navigating now to <b>File:Read Data...</b> will open the modified <i>DeltaH</i> window.</i>
<b>Note:</b>	<i>The plotted data cannot be saved to a template file, so there is no need to delete the plotted area data before saving the <i>DeltaH</i> window.</i>

## Reverting to the original *DeltaH* template

To revert to the original *DeltaH* template, reverse the steps used to create the modified template as described below:

Step	Action
1	Open the <i>DeltaH</i> window.
2	Open the <b>Y-Axis - Layer 1</b> dialog box.
3	Click on the <b>Tick Labels</b> tab.
4	Remove the check mark from the <b>Show Major Labels</b> check box.
5	Select <b>File:Save Template As...</b>



## 6.5.2 Modifying the *RawITC* template

### Introduction

The *RawITC* plot window shows bottom x-axis tick labels in units of minutes. This section describes how to change this axis scale so that the tick labels are in units of hours rather than minutes.

---

### Factoring the *RawITC* X axis tick labels by 3600

To factor the *RawITC* x-axis tick labels by 3600, follow the steps described below:

Step	Action
1	Set the <i>RawITC</i> window as the active window (by either pressing and holding the <b>ctrl</b> key then pressing the <b>tab</b> key, or selecting <i>RawITC</i> from the <i>Window</i> menu).
2	Double-click on the bottom x-axis tick labels or select <b>Format:Axis:X Axis</b> . The <b>X Axis</b> dialog box opens.
3	Click on the <b>Tick Labels</b> tab.
4	Select <b>Bottom</b> from the <b>Selection:</b> list box.
5	Enter 3600 in the <b>Divide by Factor</b> text box. Since the worksheet X values for raw ITC data are in terms of seconds, a factor of 3600 displays axis tick label values in units of hours for this axis.

**Step**      **Action**

---

- 6      Enter 2 in **Set Decimal Places** box.

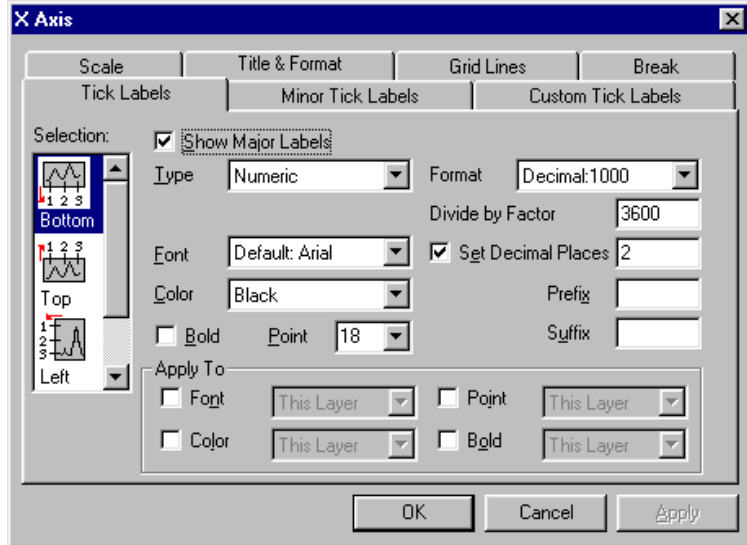

- 7      Click **OK** to close the dialog box.
- 8      Double-click on the x-axis title (it reads **Time (min)**) to open the **Text Control** dialog box, and edit the text to read **Time (hrs)**.
- 

## Saving changes into the *RawITC* template file

To save the changes into the *RawITC* template file, follow the steps described below:

**Step**      **Action**

---

- 1      Select **File:Save Template As...**
- 2      Click **Cancel** in the **Attention** dialog box to cancel changing the original *RawITC* template. Click **OK** to save the modified *RawITC* window as **Raw-ITC.OTP**.
-

## 6.5.3 Units notation in Origin

### RawITC data files

Raw data in ITC files are stored in terms of  $\mu\text{cal/s}$  vs  $s$ . The integrated area under the peaks data are stored (in the worksheet column **DH**) in units of  $\mu\text{cal}$  per injection. This is apparent if a worksheet containing integrated data is opened.

---

### Curve fitting and better publication presentation

For curve fitting and better publication presentation, both the **DeltaH** and **ITCFINAL** plot windows present the integrated heat data as **H'** (kcal per mole of ligand injected), which is more closely related to the fitting parameter **H** (calories per mole of ligand bound). That is, H' will be nearly equal to H (except for the factor of 1000) in early injections when nearly all of the ligand added is bound. The factor of 1000 is achieved by entering that factor to the y-axis tick labels, as discussed earlier in this section.

---

### x-axis values

Both the **RawITC** plot window and the upper graph in the **ITCFINAL** plot window display x-axis values in minutes, while the stored values are in seconds. In this case, the x-axis labels are factored by 60, as discussed (for the **RawITC** window) earlier in this section. Double-clicking on the top x-axis labels in the **ITCFINAL** window, will display a factor of 60 in the **Divide by Factor** text box, just as there was with the **RawITC** window. Again, this factor setting is saved as part of the **ITCFINAL** template.

---

### y-axis values

**Note:** *The y-axis data plotted in the **DeltaH** and lower **ITCFINAL** templates (i.e., data with **.NDH** extension) are normalized on moles of injectant.*

#### Viewing the experimental integrated heats

To view the experimental integrated heats in  $\mu\text{cal}$  per injection, follow the steps described below:

Step	Action
1	Double-click on the <b>Layer</b> dialog box.
2	Move the <b>_NDH</b> file out of the <b>Active</b> data and move the <b>_DH</b> file into the <b>Active</b> data.

## 6 Data analysis using Origin

### 6.5 Modifying templates

#### 6.5.3 Units notation in Origin

Step	Action
3	Double-click on the y-axis tick labels and remove the factor of 1000.

## 6.6 Advanced curve fitting

### Introduction

The model for one set of sites discussed in *Section 6.1 Basic ITC data analysis and fitting, on page 119* will work for any number of sites,  $n$ , if all sites have the same  $K$  and  $\Delta H$ . If a macromolecule has sites with two different values of  $K$  and/or  $\Delta H$ , then the model with two sets of sites must be used.

Whenever there are two sets of sites, the automatic initialization procedure is rarely effective. If the initialization parameters are extremely far away from best values, then convergence to the best values cannot take place as iterations proceed. In fact, the fit often gets worse rather than better with successive iterations. Therefore, the user must arrive at initialization parameters before the iterations can be started. An indication of poor initialization occurs when values for the  $K$  parameter become negative during the fitting procedure.

---

### In this section

This section contains the following topics:

Section	See page
6.6.1 Nonlinear curve fitting	183
6.6.2 Fitting with the <b>two sets of sites</b> model	195
6.6.3 Reverse titrations	201
6.6.4 The <b>Sequential Binding Sites</b> model	206
6.6.5 Binding of multiple ligands to transition metal ions	209
6.6.6 Enzyme/substrate/inhibitor assay	212
6.6.7 Method 1A: Enzyme assay- substrate only	213
6.6.8 Method 1B: Enzyme assay- substrate plus inhibitor	222
6.6.9 Method 2A: Enzyme assay- substrate only	224
6.6.10 Method 2B: Enzyme assay- substrate plus inhibitor	227
6.6.11 Dimer dissociation model	229

## 6 Data analysis using Origin

### 6.6 Advanced curve fitting

Section	See page
6.6.12 Competitive ligand binding	232
6.6.13 Simulating curves	235
6.6.14 Single injection method (SIM)	238

## 6.6.1 Nonlinear curve fitting

### Introduction

Origin offers two modes of its nonlinear least squares fitting tool, basic and advanced. The two modes differ substantially in the options they provide as well as in the degree of complexity. When the **NonLinear Curve Fitting: Fitting Session** is started by selecting the **One Set of Sites** ITC curve fitting model, by default Origin's nonlinear least squares fitting tool starts in the mode most recently used.

#### Basic mode

This mode allows iterative curve fitting to the built-in functions and results plotting to the graph.

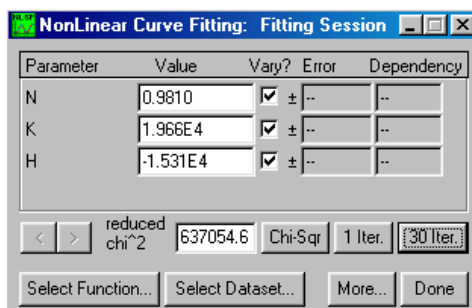

**Tip:** Click on the **More...** button to enter the advanced mode.

#### Advanced mode

In addition to the basic mode features, the advanced mode allows defining linear constraints, adjusting the configuration of the fitting parameters, simulating data and defining the fitting function.

## 6 Data analysis using Origin

### 6.6 Advanced curve fitting

#### 6.6.1 Nonlinear curve fitting

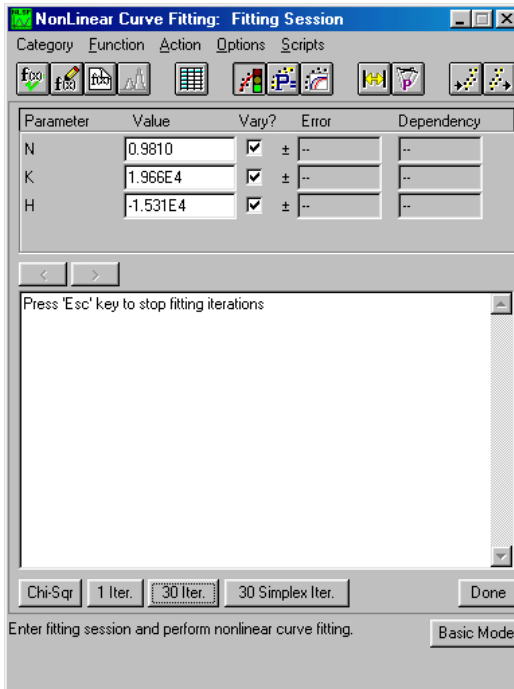

**Tip:** Click on the **Basic Mode** button to return to the basic mode.

## Aborting the NonLinear Curve Fitting: Fitting Session

To exit the **NonLinear Curve Fitting: Fitting Session** without printing the fitting parameters to the **Results** window or the graph text box, follow the steps described below:

Step	Action
------	--------

- 1 Click on the **NonLinear Curve Fitting: Fitting Session** dialog box close  button.  
A pop up window asks "**Do you want to end the current fitting session?**".
- 2 Click **No** in the pop up window.



## Controlling the fitting procedure

To control the fitting procedure, follow the steps described below:

- | Step | Action  |
|------|---|
| 1    | Enter the <b>NonLinear Curve Fitting: Fitting Session</b> .   |
| 2    | From the <b>NonLinear Curve Fitting: Fitting Session</b> window, select <b>Options:Control</b> to open the <b>Control Parameters</b> dialog box.  |
| 3    | Edit this dialog box to specify several quantitative properties of the fitting procedure. These properties directly affect the way the fitting software performs iterations.<br><br>Refer to the next section for more details. |

## The Control Parameters dialog box

### NonLinear Curve Fitting: Control Parameters dialog box



## 6 Data analysis using Origin

### 6.6 Advanced curve fitting

#### 6.6.1 Nonlinear curve fitting

##### The **Tolerance** text box

**Note:** Depending on how the fitting session was initialized, this value is preset to 0.05, but a new value can be entered for the tolerance in this text box.

The value in the **Tolerance** text box determines the number of iterations to be performed, as described below:

- Clicking on **n Iter** in the **NonLinear Curve Fitting: Fitting Session** dialog box causes the fitting software to try to perform, at most, n Levenberg-Marquardt (LM) iterations.
- If the relative change of the value of Chi-square between two successive iterations is less than the value in the **Tolerance** text box, less than n iterations are performed.
- Clicking on either the **n Iter** or the **1 Iter** button in the **NonLinear Curve Fitting: Fitting Session** dialog box causes the fitter to perform more than n iterations.

**Note:** The value, 100, is specified as 'n' in the **Max. Number of Iterations** text box.

##### The **Max. Number of Iterations** drop-down list

**Note:** This value is preset to 30, but this number can be changed to be effective during a session of Origin by entering a new value in the text box. However, the value is reset to 30 after exiting Origin.

The **Max. Number of Iterations** drop-down list allows the user to specify the value for the maximum number of iterations performed when the **n Iter** button is clicked in the **NonLinear Curve Fitting: Fitting Session** dialog box.

##### The **Derivative Delta** group

This group determines how the fitting software will compute the partial derivatives with respect to parameters for ITC fitting functions during the iterative procedure, as described below:

**Note:** The **Delta** value is preset to 0.06 with the **Maximum** as  $5 \times 10^{+30}$  and the **Minimum** as  $5 \times 10^{-30}$ .

Component	Description
<b>Fixed Delta</b> check box	Unchecking this check box (recommended for ITC users), sets the actual value of Delta (derivative step size) for a particular parameter equal to the current value of the parameter times the value specified in the <b>Delta</b> text box.
<b>Maximum</b> and <b>Minimum</b> text boxes	These boxes specify the limiting values of the actual Delta, in case a parameter value becomes too large or too small.

**Note:** If the fit curve is not converging well, try a different value for the **Delta**. For ITC users, this is typically a larger value (e.g., 0.07, 0.08). The new value is valid for the current session of Origin, but will default back to 0.01 the next time Origin ITC is opened.

### The *Parameters Significant Digits* group

**Note:** The significant digits value is preset to 4 for all parameters.

The **Parameters Significant Digits** group allows the user to select values for the significant digits for each parameter from the associated drop-down list. Selecting **Free** from the drop-down list uses the current Origin setting.

**Note:** This will only effect the text box display in the **NonLinear Curve Fitting: Fitting Sessions** dialog box.

### The *Weighting Method* drop-down list

The **Weighting Method** drop-down list allows the user to select how different dataset points are to be weighted when computing Chi-square during the iterative procedure. The selections are:

- **No weighting**
- **Instrumental**
- **Statistical**
- **Arbitrary dataset**
- **Direct weighting**

**Note:** It is recommended that the default option of **No weighting** be used for all ITC data unless there is a strong reason to choose a more appropriate for a particular data set. No weighting assumes that each data point has the same absolute error probability.

### Returning to the *NonLinear Curve Fitting: Fitting Session* dialog box

To return to the **NonLinear Curve Fitting: Fitting Session** dialog box, click on the  button or select **Action:Fit**.

## Using macromolecule concentration, rather than n, as a fitting parameter

### Introduction

Even though the value for the stoichiometric parameter, n, can be distinguished from independent studies, an accurate estimate for macromolecule concentration  $M_t$  may be used (Sigurskjold, B. W. *et al.* Sensitive titration microcalorimetric study of the binding of *Salmonella* O-antigenic oligosaccharides by a monoclonal antibody. *Eur. J. Biochem.* **197**, 239-246 (1991)). Using Origin,  $M_t$  (along with the correct binding constant and heat of binding) can be determined from curve-fitting.

### Determining $M_t$ from curve fitting

To determine  $M_t$  from curve fitting, follow the steps described below:

## 6 Data analysis using Origin

### 6.6 Advanced curve fitting

#### 6.6.1 Nonlinear curve fitting

Step	Action
1	Enter an estimated macromolecular concentration, $M_t^*$ , into the <b>Concentrations</b> dialog box.
2	Select the model for curve-fitting and proceed to find the best fit in the usual way.  The values obtained for the binding constant and heat of binding will be correct since these depend only on the accuracy of the ligand concentration. However, the best value for the stoichiometric parameter, $n^*$ , will be incorrect since this is assigned manually by the operator and, after making the correct assignment $n$ , determines the actual $M_t$ .
3	Once curve-fitting is completed, calculate the correct $M_t$ , which is equal to the incorrect concentration $M_t^*$ times the ratio $n^*/n$ .
4	Check if the above procedure is correct by calling the <b>RNAHHH.ITC</b> data into Origin, performing curve-fitting using the correct concentration, and recording the best values of parameters $n$ , $K$ and $H$ as the correct values.
5	Change the concentration by multiplying the correct concentration in the cell by 2. Enter that incorrect value into the <b>Concentrations</b> dialog box.
6	Perform curve-fitting again.  The new, incorrect value of $n$ is exactly 50% of the correct value obtained using the correct concentration. The values for binding constant and heat of binding should be the same in both the cases.

## Global Fitting

Origin permits global fitting to be performed on multiple datasets.

Step	Action
1	Start the manual version of the MicroCal iTC <sub>200</sub> Origin software as described in <i>Section 6.1.1 Starting Origin, on page 120</i> .
2	Click Read Data. The Open dialog box opens, with the ITC Data (*.itc?) selected as the Files of type:. Select <code>C:\Origin70\Samples\ itc0523c001.itc</code> and <code>itc0523c002.itc</code> from the files list.

**Step Action**

3 Click on the **One Set of Sites** Model Fitting button.

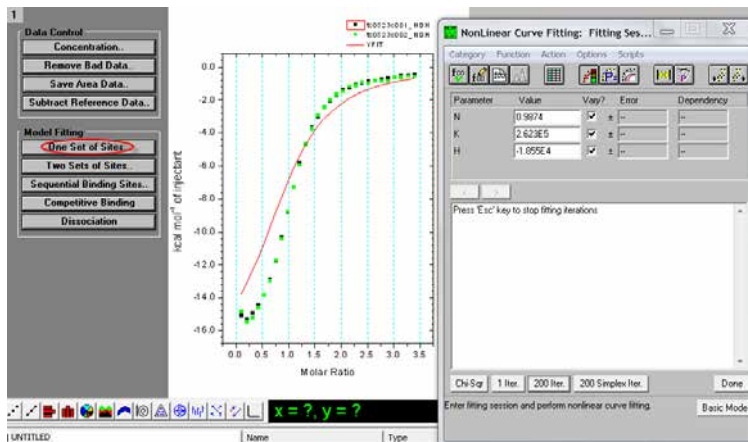

4 Click the spreadsheet icon in the **Fitting Session** Window.

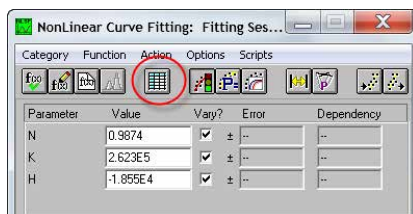

## 6 Data analysis using Origin

### 6.6 Advanced curve fitting

#### 6.6.1 Nonlinear curve fitting

Step	Action
------	--------

5	This opens the <b>Select Dataset</b> window.
---	--

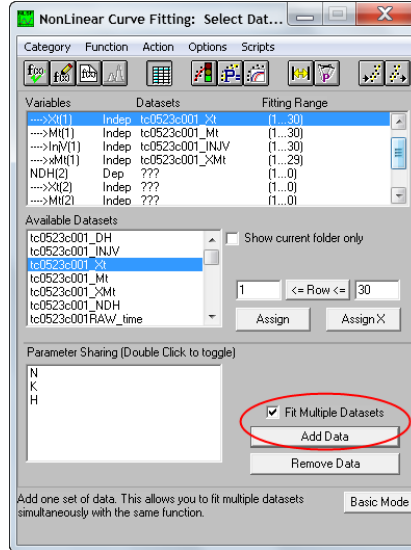

Click the **Fit Multiple Datasets** checkbox as depicted above, which enables the Add Data button. Pressing this button will add datasets to the list above. Notice the question marks. The user must assign the data manually, from the Available Datasets list. The following steps must be followed:

**Step Action**

- 1 Click **NDH(2) Dep ???** in the topmost window as shown below. Click **tc0523c002\_NDH** in the middle window. Then click **assign**. Notice Origin mistakes the Xt vector for the XMt vector. Do not correct this yet.

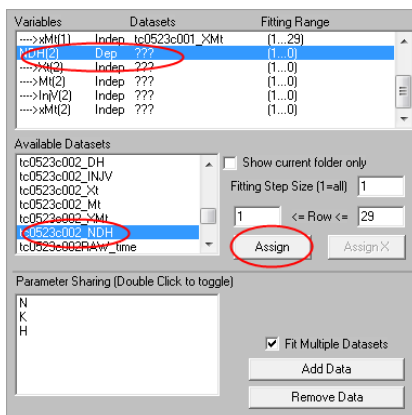

- 2 Assign the other 3 variables: Mt, InjV, and xMt, leaving the second variable uncorrected.

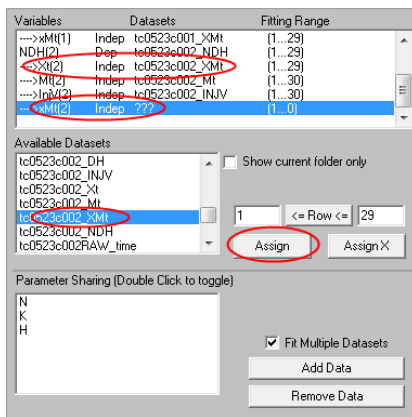

## 6 Data analysis using Origin

### 6.6 Advanced curve fitting

#### 6.6.1 Nonlinear curve fitting

#### Step Action

- 3 Finally, assign the second variable, Xt, to the corresponding dataset's Xt vector.

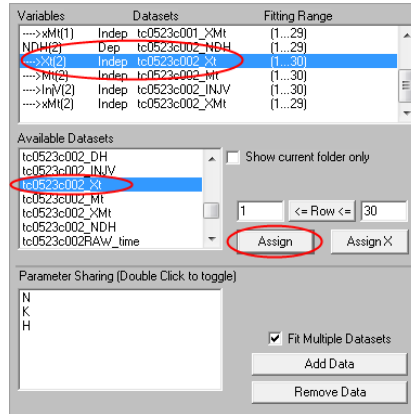

- 4 Double-click parameters in the **Parameter Sharing** box to have them fit globally to the 2 datasets.

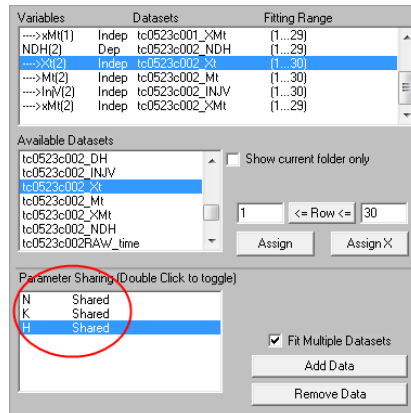



**Step Action**

- 5 Click the button depicted below first and then secondly check the **Generate Fit Curve** checkbox.

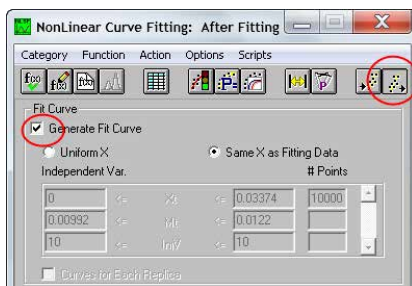

- 6 Click the stoplight button to return to the original **Fitting Session** window.

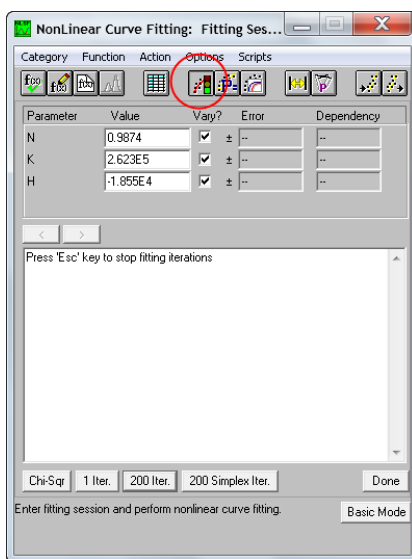

## 6 Data analysis using Origin

### 6.6 Advanced curve fitting

#### 6.6.1 Nonlinear curve fitting

#### Step Action

- 7 Perform curve fitting as normal, acknowledge the warning after pressing **Done**, and you are left with a curve fitting both datasets, with the same variables.

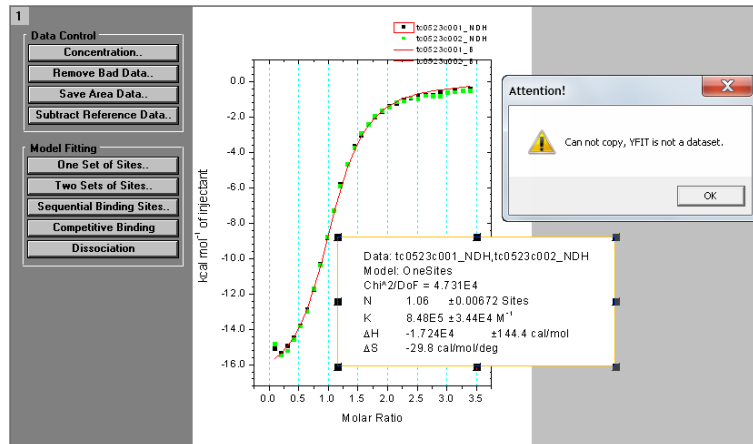

## 6.6.2 Fitting with the **two sets of sites** model

### Titration experiments with ovotransferrin

The protein, ovotransferrin, has two very tight, non-identical sites for binding ferric ions; one located in the N domain and one in the C domain. The Origin area data **FeOTF54.NDH** shown below were obtained by titrating ovotransferrin with ferric ion. Injections 1 to 5 titrate primarily the stronger N site, injections 7 to 11 primarily the C site, while injections 13 to 15 result in no binding since both the sites are already saturated.

---

### Fitting ovotransferrin titrations with the two sets of sites model

To fit ovotransferrin titrations with the two sets of sites model, follow the steps described below:

Step	Action
1	Select <b>File:New:Project</b> (or click on the <b>New Project</b> button) to create a new project.
2	Click on the <b>Read Data...</b> button in the <b>RawITC</b> window and select <b>Area Data (*.DH)</b> from the <b>File of type</b> drop-down list.

## 6 Data analysis using Origin

### 6.6 Advanced curve fitting

#### 6.6.2 Fitting with the *two sets of sites* model

Step	Action
------	--------

3	Go to the C:\Origin70\Samples folder, and open <i>FeOTF54.DH</i> .
---	--

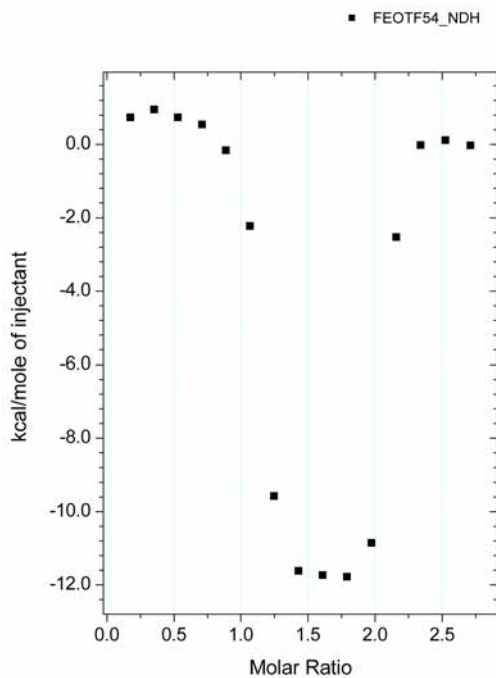

**Step**      **Action**

4 Click the **Two sets of Sites** button in the **DeltaH** window.

Origin opens the **NonLinear Curve Fitting: Fitting Session** dialog box, but produces an attention dialog box and, upon clicking **200 Iter.**, a very poor initial fit to the curve.

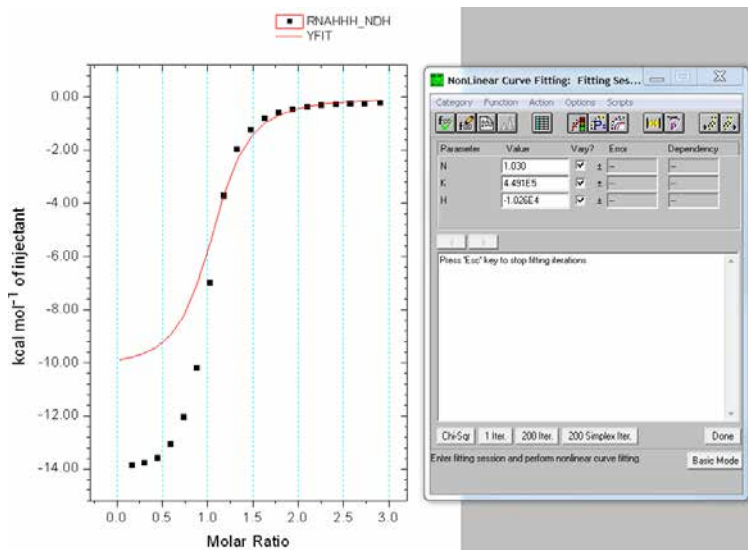

5 Click **OK** in the warning dialog to proceed.

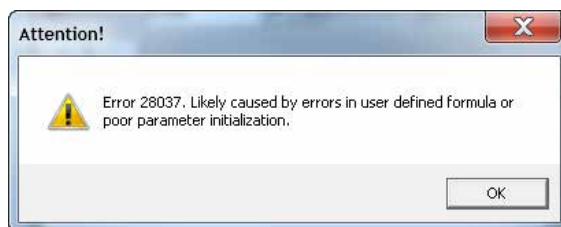
**Note:**

The auto initialization produces a curve, which represents the data very poorly. If iterations are started from this, the fit will not converge. With experience, a satisfactory initialization that leads to convergence can be obtained.

## 6 Data analysis using Origin

### 6.6 Advanced curve fitting

#### 6.6.2 Fitting with the *two sets of sites* model

## Manual initialization

Examination of the experimental points shows that the first few injections at a molar ratio below 1 produce ~1 kcal per mole of injectant, changing to ~-12 kcal for molar ratio 1 to 2 and finally changing to 0 at molar ratios larger than 2.

To begin manual initialization, follow the steps described below:

Step	Action
1	<p>Enter 1 into both the <b>N1</b> and <b>N2</b> parameter boxes in the <b>NonLinear Curve Fitting: Fitting Session</b> dialog box.</p> <p><b>Note:</b> <i>H1 must be near +1000 and H2 close to -12,000.</i></p>
2	<p>Enter <b>H1</b> as +1000 and <b>H2</b> as -12,000 into the appropriate parameter boxes.</p> <p><b>Note:</b> <i>Since the experimental heats fall off quickly from the H1 value to the H2 value, it is clear that K1 must be much larger than K2, and because the heat changes abruptly from the H2 value to zero (i.e., beginning with the eleventh injection) it is also clear that K2 itself must be large (i.e., even though it is smaller than K1).</i></p>
3	<p>Enter 1e8 into the <b>K1</b> parameter box, and 1e6 into the <b>K2</b> parameter box.</p> <p><b>Note:</b> <i>Do not insert a space before or after the e when using exponential notation, or Origin will not accept the value.</i></p>

**Step**      **Action**

- 4 Click on the **Chi-Sqr** button in the dialog box. Origin draws a new fit curve using the entered parameters, which is a much better representation of the data.

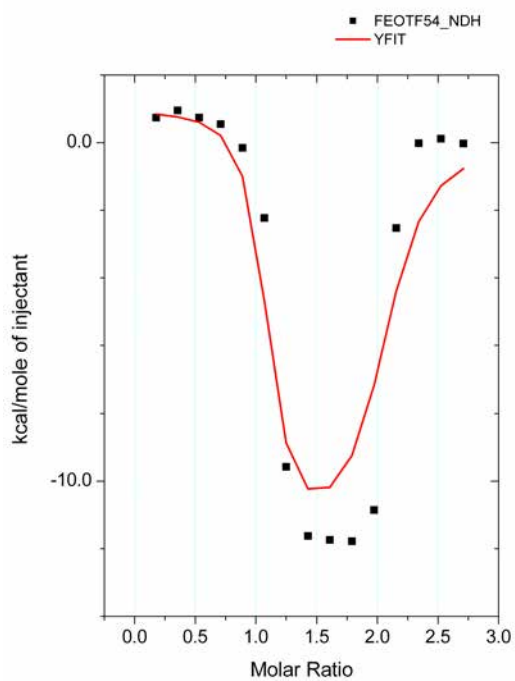

## 6 Data analysis using Origin

### 6.6 Advanced curve fitting

#### 6.6.2 Fitting with the *two sets of sites* model

Step	Action
------	--------

- |   |   |
|---|---|
| 5 | Select the <b>200 Iter.</b> button a few times, and convergence occurs with a final $\text{Chi}^2$ of about 33,000. |
|---|---|

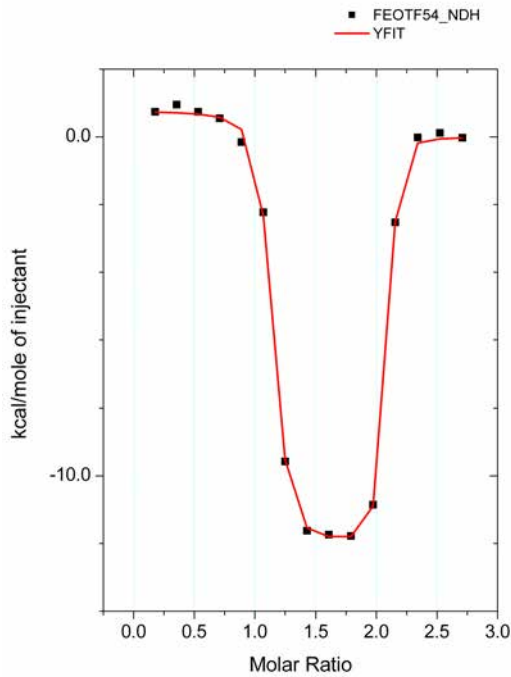

**Note:**

*N1 and N2 are nearly the same magnitude, but not quite. It would be interesting to see if a fit of nearly equal quality could be obtained with N1 and N2 exactly equal to each other, although theoretically they should each be 1.0.*

- |   |  |
|---|--|
| 6 | Enter the value 1.0 into the <b>N1</b> and <b>N2</b> parameter value box.  |
| 7 | Click the <b>N1</b> and <b>N2</b> checkboxes to remove the checkmark, and continue the iterations. This fit is not as good, but this could also mean that the concentrations were incorrect. |



## 6.6.3 Reverse titrations

### Introduction

Whenever the ligand and macromolecule each have only one site for interaction with the other, then the system is symmetrical, and it does not matter which of the two is loaded into the sample cell and which into the injection syringe. It is important to carefully record the proper concentration of the species in the syringe and cell.

In cases where the ligand is sparingly soluble and the macromolecule is not, it may be useful to load the ligand into the sample cell since the starting concentration then does not need to be so high. Cases where the ligand is loaded in the sample cell and the macromolecule in the syringe are often called reverse titrations. The situation is more complicated if the macromolecule has more than one site (even if there is only one set of sites).

---

### Principle

For this discussion, assume that the macromolecule has two fairly strong sites with differing affinity for the ligand. The measured heat change will depend on where the ligand and the macromolecule are loaded, syringe or sample cell.

If the macromolecule is loaded in the sample cell and the ligand in the syringe, then the tightest of the two sites will titrate in the early injections with heat change  $H_1$  and the weakest of the two will titrate in subsequent injections with heat change  $H_2$  until both sites are saturated, whereupon the heat change goes to zero.

If the ligand is loaded into the sample cell and the macromolecule into the syringe, then the ligand will be in excess in the early injections and both the sites will titrate with a heat change of  $H_1 + H_2$ .

Once sufficient macromolecule (i.e., molar ratio of macromolecule/ligand of 0.5) has been added to bind all of the ligand as a 2-to-1 complex, further injections of the macromolecule will result in some of the ligand being removed from the weaker site in the 2-to-1 complex, so that it can bind to the stronger site on the newly-injected macromolecule. The heat change for this second phase of the titration will then be  $H_1 - H_2$ , assuming that site 1 is sufficiently strong. In such a case, all of the ligand will be in the 1-to-1 complex when the molar ratio reaches 1.0, and further injections of macromolecule will give zero heats.

---

### Example

#### Fitting by the *Two sets of Sites* model

To open the *OTFFE3.DH* file, follow the steps described below:

## 6 Data analysis using Origin

### 6.6 Advanced curve fitting

#### 6.6.3 Reverse titrations

Step	Action
1	Select <b>File:New:Project</b> (or click on the <b>New Project</b> button) to create a new project.
2	Click on the <b>Read Data...</b> button in the <b>RawITC</b> window.
3	Select <b>Files of type:Area Data (*.DH)</b> .
4	Navigate to the <code>C:\Origin70\Samples</code> folder.
5	Double-click on <b>OTFFE3</b> in the <b>File Name</b> list. The normalized ( <b>.NDH</b> ) data are populated in the plot window.

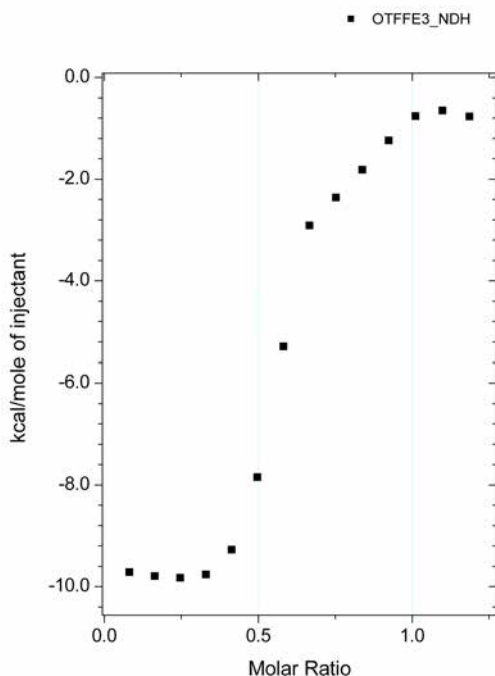

The data in file **OTFFE3.DH** were obtained with the macromolecule (ovotransferrin) in the syringe and the ligand (a chelated form of ferric ion) in the sample cell. Injections 1 to 5 correspond to formation of the diferric form of ovotransferrin with heat change  $H1 + H2$ . Injections 8 to 14 involve conversion of the diferric form into the monoferric form with heat change  $H1 - H2$ .

Step	Action
------	--------

- 6 Select **Ligand is in (Cell)** from the **Analysis** menu before fitting to this data.

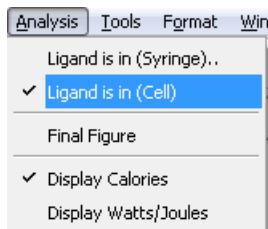

This switches the settings, letting Origin know that the ligand is now in the cell. Confirm this by clicking on the **Analysis** menu again and noting that the checkmark is next to **Ligand is in (Cell)**.

**Note:**

Origin defines the "macromolecule" as the species with  $n$  greater than 1.0 and the "ligand" as the species with only one site, irrespective of their molecular weights.



- 7 Click **OK**.
- 8 Click on the **Two sets of Sites** button to select the appropriate fitting model.

**Note:**

The default fitting parameters will lead to a satisfactory convergence in this case but can be improved before beginning iterations.

### Changing values in the **Parameters Significant Digits** group

The first several injections indicate that  $H1 + H2$  equals about  $-10,000$  cal/mole. Change the values in the **Parameters Significant Digits** group as described below:

Step	Action
------	--------

- 1 Start off with values of  $-7000$  for **H1** and  $-3000$  for **H2**.
- 2 Set **n1** and **n2** equal to  $1.0$ .
- 3 Uncheck the **N1** and **N2** checkboxes.
- 4 Enter  $1e8$  for **K1** and  $1e6$  for **K2**.

## 6 Data analysis using Origin

### 6.6 Advanced curve fitting

#### 6.6.3 Reverse titrations

Step	Action
------	--------

- |   |  |
|---|--|
| 5 | Select <b>Chi-Sqr</b> , and use the <b>1 Iter.</b> command to iterate once. Iterating a second time generates an error. Complex models like this one can be heavily dependent on initial parameters. |
| 6 | Constrain <b>K1</b> by pressing the icon circled below.  |

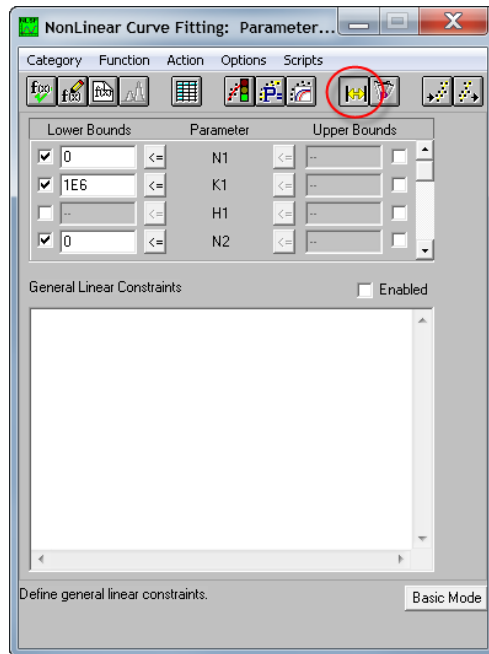

Check that the **Lower Bounds** checkbox is checked for **K1**. Enter 1e6 and press the spotlight icon to return to the fitting session.

- |   |   |
|---|---|
| 7 | Click <b>200 Iter.</b> to converge on a solution. |
|---|---|

## Running experiments with poor fitting parameters

This section describes how experiments with poorly defined fitting parameters can be run. This situation will most likely occur with two sets of sites, where  $K_1$  and  $K_2$  values are less than 10-fold different. It is even possible that the set of "best fit" parameters may be quite different depending on the initialization parameters, which are used to start the fit; i.e., the curve-fitting routine can become trapped in a local minimum for Chi-square and be unable to find the global minimum. This can be detected by starting with several different sets of initialization parameters to see if the same final minimum with nearly the same fitting parameters is achieved.

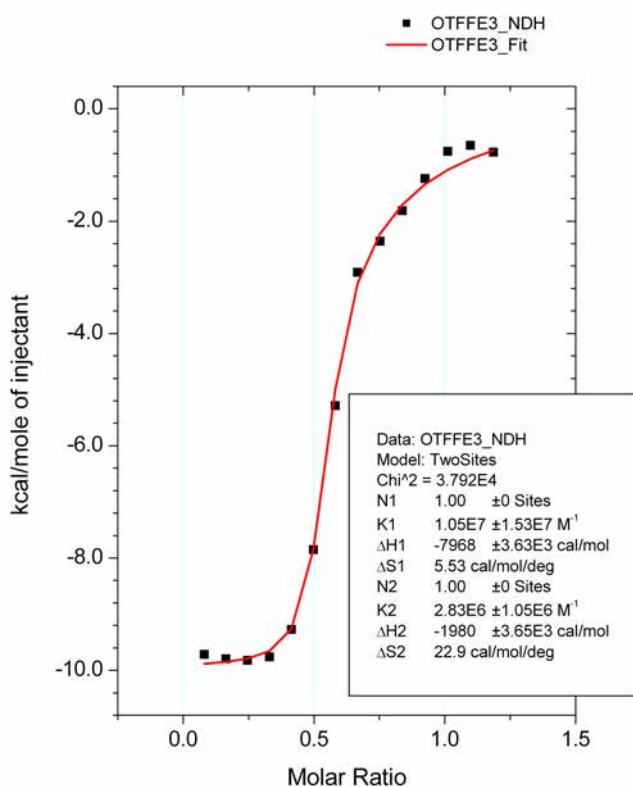

## 6.6.4 The *Sequential Binding Sites* model

### Introduction

The models discussed previously have been concerned with independent sites. It often occurs in biological systems that the binding of a ligand to one site will be influenced by whether or not ligands are bound to any of the other sites. If the sites are non-identical, then binding studies alone cannot determine whether the sites are independent or interacting. On the other hand, if the sites within a molecule are known to be identical, then it may be possible to determine if they are interacting.

---

### Cooperativity

Consider the simplest case, that of a macromolecule with two identical sites, for example, a homodimeric protein. If the sites are identical, then it is not possible to distinguish between binding at the first site and binding at the second site, but there is a sequential saturation since the first ligand ( $K_1$ ,  $H_1$ ) to bind has more empty sites to choose from than does the second ligand ( $K_2$ ,  $H_2$ ), as described in *Appendix A Equations used for fitting ITC data, on page 310*. Cooperativity can be determined at half saturation when the dominant molecular forms are the macromolecules with either two or no ligands attached, with very little of the singly-liganded form.

#### Positive cooperativity

A system with positive cooperativity means  $K_2 > K_1$ . Positive cooperativity is generally more difficult to distinguish from binding studies alone, since the tendency is for both sites on any single molecule to saturate together with heat change  $H_1 + H_2$ , so that only one "phase" is seen in the titration curve.

#### Negative cooperativity

A system with negative cooperativity means  $K_1 > K_2$ . Negative cooperativity can be more easily detected from binding studies, since there will be two different "phases" occurring: the strong binding of the first ligand and weaker binding of the second.

---

### Fitting data with *Sequential Binding Sites* model

To fit the data with *Sequential Binding Sites* model, follow the steps described below:

Step	Action
1	Select <b>File:New:Project</b> (or click on the <b>New Project</b> button) to open a new project.

- | Step | Action  |
|------|---|
| 2    | Click on the <b>Read Data...</b> button in the <b>RawITC</b> window, then select <b>Area Data (*.dh)</b> from the <b>File of Type:</b> drop-down box. |
| 3    | Go to the <code>c:\Origin70\Samples</code> sub-folder, and double-click on <b>protb.dh</b> .  |

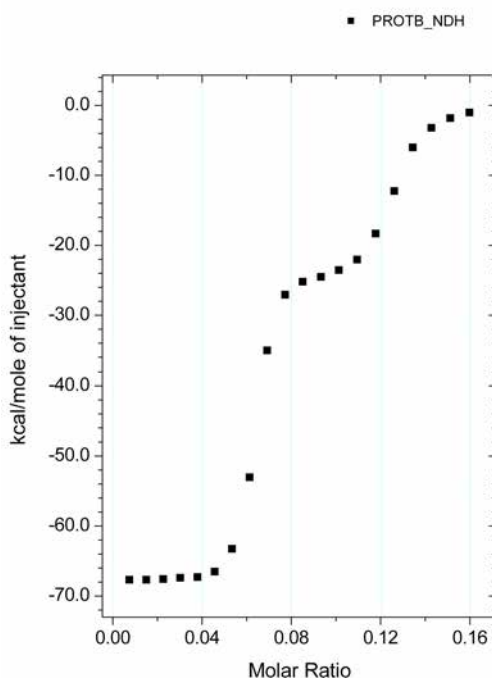

Since there are clearly two "phases" to this binding isotherm, it exhibits negative cooperativity.

- |   |   |
|---|---|
| 4 | Click the <b>Concentration..</b> button in the <b>DeltaH</b> window to edit the concentrations for this data before fitting.  |
| 5 | Enter the following values in the dialog box: 20 . 7 mM ligand in the syringe; 0 . 494 mM macromolecule in the cell; 4 $\mu$ l injection volume; 1 . 32 ml cell volume. |

## 6 Data analysis using Origin

### 6.6 Advanced curve fitting

#### 6.6.4 The *Sequential Binding Sites* model

Step	Action
6	<p>Click <b>OK</b>.</p> <p>The y-axis automatically rescales according to the changes made.</p> <p><b>Note:</b></p> <p><i>Make sure that <b>Ligand is in (Syringe)</b> has the check mark next to it in the <b>ITC</b> menu indicating it is the active mode. If the check mark is next to the <b>Ligand is in (Cell)</b>, select the menu item <b>Ligand is in (Syringe)</b>. This causes the mode to switch to having the ligand in the syringe.</i></p>
7	<p>Click the <b>Sequential Binding Sites</b> button in the <b>DeltaH</b> window to fit the data to the interacting sites model.</p>
8	<p>Click on the <b>Chi-Sqr</b> button and enter 2 for the number of sites. Enter guesses of <math>1e8</math>, <math>-8000</math>, <math>1e6</math>, <math>-3000</math> for the parameters <b>K1</b>, <b>H1</b>, <b>K2</b>, and <b>H2</b>, respectively.</p>
9	<p>Click the <b>200 Iter.</b> button several times, until a satisfactory convergence is obtained.</p>

### Conclusion

The above data can be deconvoluted with the default initialization parameters based on the following observations:

- The binding constant for the second ligand is about 70 times weaker than the binding constant for the first ligand.
- The heat of binding is also less exothermic.
- Stoichiometric parameters  $n_1$  and  $n_2$  are not included as floating parameters with the model of interacting sites. This would allow a non-integral number of ligand molecules to bind in each step, which is a physical impossibility.
- Accurate concentrations of ligand and macromolecule are more important here since concentration errors cannot be overcome by non-integral values of  $n_1$  and  $n_2$  as is the case with the model of two independent sites.

### Systems with identical binding sites

Systems with identical binding sites have statistical degeneracy that influences the saturation profile.

For example, in a system with two identical sites the first ligand has two empty sites at which to bind while the second ligand has only one. The binding constants reported in the parameter box are phenomenological binding constants, which include effects from degeneracy. To remove these effects and compare intrinsic binding constants  $K^0$  at each site, refer to eq (19) in *Appendix A Equations used for fitting ITC data, on page 310*.



## 6.6.5 Binding of multiple ligands to transition metal ions

### Introduction

The binding of multiple ligands to transition metal ions is another example where the sequential binding model is appropriate, and where all sites are identical in the apo-metal ion.

### Practice example

Practice fitting data for binding of multiple ligands to transition metal ions using the **Sequential Binding Sites** model on the sample file **Persson7.ITC** (contains data on the binding of four  $\text{Br}^-$  to  $\text{Cd}^{2+}$  to form  $\text{CdBr}_4^{2-}$ ) as described below:

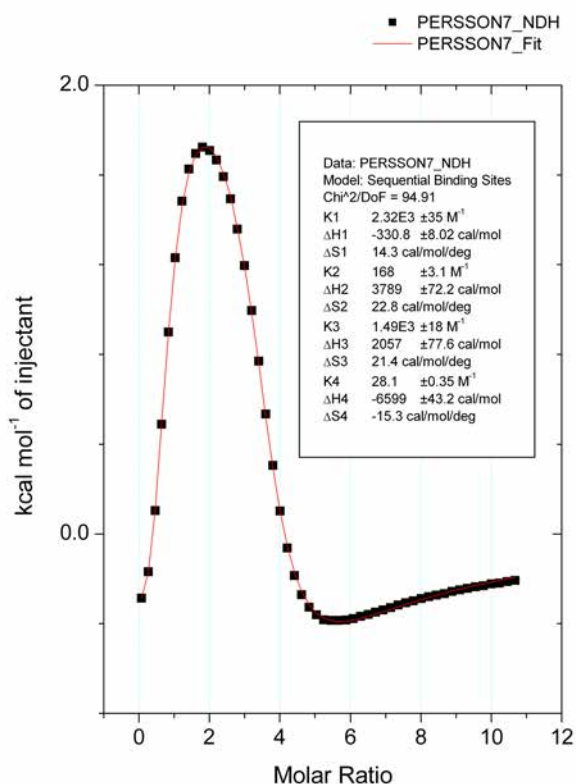

## 6 Data analysis using Origin

### 6.6 Advanced curve fitting

#### 6.6.5 Binding of multiple ligands to transition metal ions

- 1 Open the file and perform curve fitting to obtain binding parameters for each of the four  $\text{Br}^-$  using the **Sequential Binding Sites** model.

**Note:** *The concentrations of both,  $\text{Br}^-$  and  $\text{Cd}^{2+}$  are correct as contained in the file.*

- 2 Click the **200 Iter.** button several times to obtain a satisfactory convergence without selecting the initial parameters manually.
  - 3 Practice and try to improve the initialization.
- 

## Using the *Sequential Binding Sites* model with non-identical sites

### Difference between *Two sets of Sites* model and *Sequential Binding Sites* model

The Sequential Binding Sites model can also be applied to systems with non-identical sites.

The **Two sets of Sites** model, considers:

- the saturation of individual sites on the same molecule
- assumes they saturate independently of one another
- uses three fitting parameters for each site; N, K and H.

The **Sequential Binding Sites** model assumes:

- a fixed sequence of binding, i.e., the first ligand, which binds to an individual molecule always binds to site 1, the second ligand, which binds to an individual molecule always binds to site 2, etc.
- the number of sequential sites must be exactly integral (1,2,3,...) so there is no fitting parameter equivalent to N
- best-fit is determined by only two parameters, K and H, at each site once the total number of sites has been selected by the operator

**Note:** *For a molecule which has 2 sites with quite different affinity (e.g., K values different by a factor of five or more), the two models tend to give equivalent values of K and H since thermodynamics will dictate binding to the site of highest affinity first. However, when K values at two independent sites are more or less nearly equivalent, sequential binding will not be strictly followed.*

### Advantages of *Sequential Binding Sites* model over *Two sets of Sites* model

The following basic advantages of **Sequential Binding Sites** model over **Two sets of Sites** model make it the only choice available for providing a unique phenomenal characterization of binding parameters for some multi-site systems:

- the smaller number of fitting parameters used for each site
- ability to provide a unique fit even for systems with four binding sites (if the K and/or H values are sufficiently different for each site)

**Note:** *Using a model for independent sites, it would be extremely difficult to obtain a unique fit for more than two sets of sites, which is why no fitting model for three sets of independent sites has been included in this software.*

---

## 6.6.6 Enzyme/substrate/inhibitor assay

### Introduction

There are two different methods for carrying out an enzyme assay. These methods are discussed in *Enzyme/substrate/inhibitor assay, on page 317*, where the appropriate equations are also included. Both methods assume that no significant product inhibition occurs.

The methods are summarized in the table below and are explained in detail in the following four sections.

Method	Enzyme Assay
--------	--------------

- |   |  |
|---|--|
| 1 | A: Enzyme assay- substrate only ( <i>Section 6.6.7 Method 1A: Enzyme assay- substrate only, on page 213</i> )<br>B: Enzyme assay- substrate plus inhibitor ( <i>Section 6.6.7 Method 1A: Enzyme assay- substrate only, on page 213</i> ) |
| 2 | A: Enzyme assay- substrate only ( <i>Section 6.6.7 Method 1A: Enzyme assay- substrate only, on page 213</i> )<br>B: Enzyme assay- substrate plus inhibitor ( <i>Section 6.6.7 Method 1A: Enzyme assay- substrate only, on page 213</i> ) |

## 6.6.7 Method 1A: Enzyme assay- substrate only

### Principle

The basic principle of this method is described below:

Step	Action
1	An enzyme solution is in the sample cell and the experiment involves a single injection of substrate solution into the sample cell.
2	Immediately after the injection, the calorimeter baseline shifts prominently to reflect heat effects that occur due to the decomposition of substrate as it comes into contact with the enzyme.  <b>Note:</b> <i>Because of the finite response time of the instrument, it takes a few minutes before the calorimetric signal becomes equilibrated with the actual heat from substrate turnover.</i>
3	After all the substrate has reacted, the baseline returns to its original position prior to the next injection of substrate.

### Analysis

Analysis of the decay resulting from the substrate decomposition curve allows determination of:

- the Michaelis parameters,  $K_M$  (mM) and  $K_{cat}$  ( $s^{-1}$ )
- the heat of substrate decomposition,  $\Delta H$

If a second similar experiment is carried out with an inhibitor in the sample cell along with the enzyme, then analysis of the resulting decay curve will:

- use parameters determined in the first experiment ( $K_M$ ,  $K_{cat}$  and  $\Delta H$ ) as input parameters and use only  $K_I$  as a fitting parameter
- determine the Michaelis inhibitor constant,  $K_I$  (mM)

## Procedure

To employ Method 1: Enzyme assay- substrate only, follow the steps described below:

- | Step | Action   |
|------|--|
| 1    | Select <b>File:New:Project</b> .<br>A new Origin project opens to display the <b>RawITC</b> plot window.         |
| 2    | Click the <b>Read Data..</b> button.   |
| 3    | Click the drop-down arrow of the <b>Files of type</b> text box and select <b>Enzyme Assay (*.it?)</b> file type. |

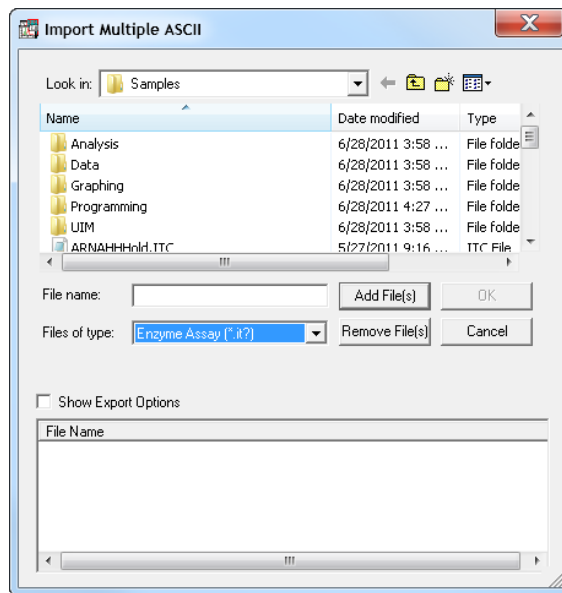

Step	Action
------	--------

- |   |   |
|---|---|
| 4 | Navigate to the <code>C:\Origin70\Samples</code> folder and select <b>M1NoInhibitor.itc</b> from the <b>File Name</b> list, and click <b>OK</b> . |
|---|---|

The **Enzyme Assay** dialog box opens, allowing the selection of one of the four models.

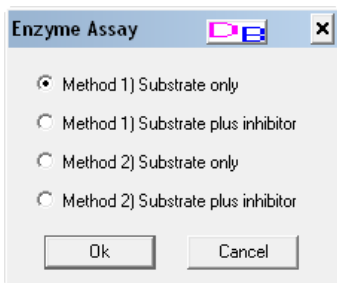

- |   |  |
|---|--|
| 5 | Select <b>Method 1) Substrate only</b> and click <b>OK</b> . |
|---|--|

The **Method 1) Substrate only** dialog box opens up. If no value is entered for  $\Delta H$ , the program calculates  $\Delta H$  (using the formulae in *Enzyme/substrate/inhibitor assay, on page 317*).

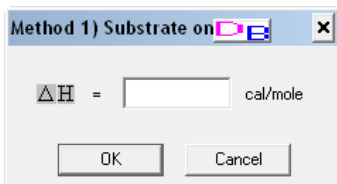

Step	Action
------	--------

- |   |  |
|---|--|
| 6 | Click <b>Cancel</b> .<br>The data file is read in and plotted in a new window. |
|---|--|

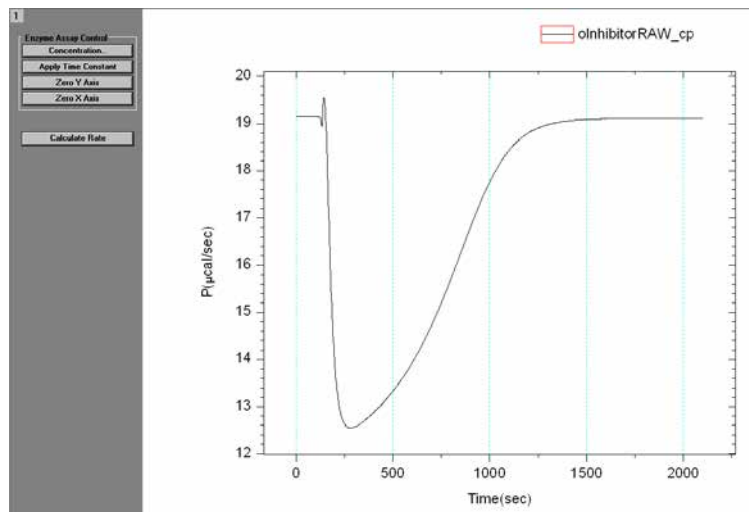

## Concentration

**Note:** The concentration and injection volume values which displayed initially are those entered manually before the experiment starts. The cell volume is a constant, which is stored in the data collection software. This value is read by Origin whenever an ITC data file is called. Always check that the concentration values are correct for each experiment. Incorrect values will negate the fitting results.

To edit the concentration values, follow the steps described below:



Step	Action
------	--------

- |   |  |
|---|--|
| 1 | Click the <b>Concentration</b> button.<br>The concentration dialog box, <b>For Data olnhibitor</b> , opens showing the concentration values and the cell volume. |
|---|--|

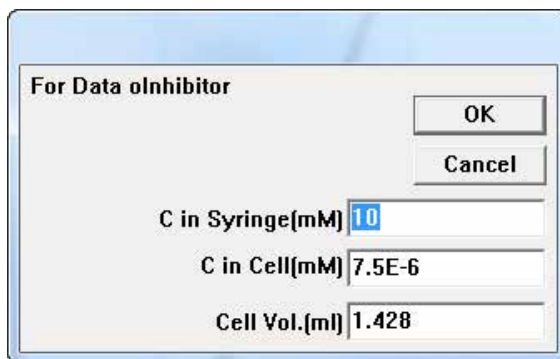

- |   |  |
|---|--|
| 2 | Enter a new value in the appropriate text box.   |
| 3 | Click <b>OK</b> to save the new values or <b>Cancel</b> to use the default values displayed. |

## Applying time constant

### Response time of the instrument

The response time of the instrument is dependent on the feedback gain mode used during the experiment. Typical values for the relaxation time are ~18.5 s for high gain, 51 s for low gain and 72 s for no active feedback (passive) gain mode. The actual values are measured for the instrument and stored in the **VPViewer.ini** file.

### Methods to reduce the effect of instrument response time on final parameters

When a substrate is injected into the enzyme solution, it decomposes immediately. However, it takes approximately one minute after the injection before the baseline has reached the position where it reflects the full amount of heat being released in the cell because of the finite response time of the instrument.

There are two software procedures designed to reduce the effect that the instrument response time exerts on final parameters obtained from the data, as described below:

## 6 Data analysis using Origin

### 6.6 Advanced curve fitting

#### 6.6.7 Method 1A: Enzyme assay- substrate only

Procedure	Action
1	The first procedure is activated from the <b>Apply Time Constant</b> button. Knowing the actual time constant for the instrument (determined by Malvern Instruments before shipment, and stored in Origin), the experimental data are mathematically "corrected" to remove the response time effect on the experimental data. When this operation is carried out, the old data is transferred out of the active window and the corrected data is displayed in the active window.
2	The second procedure is activated by clicking the <b>Truncate Data</b> button. Remove that portion of the data immediately after the injection where distortion remains even after correcting the time constant.

### Applying time constant

To apply time constant, follow the steps described below:

Step	Action
1	Click the <b>Apply Time Constant</b> button. The time constant dialog box opens. The value of 18.5 is correct for high gain feedback mode.



2	Click <b>OK</b> or <b>Cancel</b> . <b>Note:</b> <i>Once the time constant correction has been applied, the original data is replaced in the active window by the corrected data.</i>
---	--

## Zeroing the axes

### Zeroing the y-axis

To zero the y-axis, follow the steps described below:

Step	Action
1	Select the <b>Zero Y Axis</b> button. The cursor will turn to a cross hair.

Step	Action
2	Double-click a point to place it at $y=0$ .  <b>Tip:</b> Choose a point on the flat part of the baseline before the injection is made.

### Zeroing the x-axis

To zero the x-axis, follow the steps described below:

Step	Action
1	Select the <b>Zero X Axis</b> button. The cursor will turn to a cross hair.
2	Click a point, then use the arrow keys to move the point and then press <b>enter</b> to select that point.  <b>Note:</b> <i>Zero the x-axis at the point where the injection is made (where the first small deflection in the baseline is observed).</i>

## 6 Data analysis using Origin

### 6.6 Advanced curve fitting

#### 6.6.7 Method 1A: Enzyme assay- substrate only

## Calculating the rate

To calculate the rate, follow the steps described below:

Step	Action
------	--------

- |   |   |
|---|---|
| 1 | Click the <b>Calculate Rate</b> button. |
|---|---|

The rate is calculated and plotted in a new window, in a graph of the Rate (mM/s) vs [S] (mM) where [S] is the concentration of the unreacted substrate in the cell.

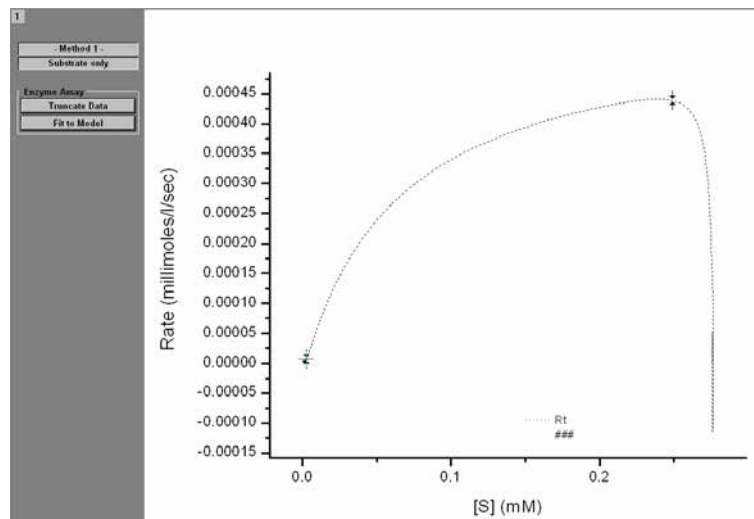

- |   |   |
|---|---|
| 2 | Click the <b>Truncate Data</b> button to eliminate the artifact at the start of the experiment or click <b>Fit to Model</b> to open Origin's nonlinear least squares curve fitting to perform the fitting iterations. |
|---|---|

## Truncating data

To truncate data, follow the steps described below:

Step	Action
------	--------

- |   |  |
|---|--|
| 1 | Click the <b>Truncate Data</b> button.                     |
| 2 | Move the data markers to the positions shown.              |
| 3 | Double-click on one of the markers or press <b>enter</b> . |

This will eliminate the data obtained immediately after the injection of the substrate, before the calorimeter equilibrates with the ongoing reaction.

## Fitting to model

To fit to model, follow the steps described below:

- | Step | Action   |
|------|--|
| 1    | Click the <b>Fit to Model</b> button.<br>The <b>Fitting Sessions</b> dialog box opens.   |
| 2    | Click the <b>200 Iter.</b> button, two or three times, to make sure that the Chi-square value is no longer decreasing.   |
| 3    | Click <b>Done</b> to end the fitting session.<br>$K_{cat}$ and $K_m$ are used as the variable parameters during the iterative fitting and the best values, along with $\Delta H$ , are reported in the output parameter box. |

### Note:

$\Delta H$  is determined from the total area of the negative peak of the raw data, but is not used as a fitting parameter.

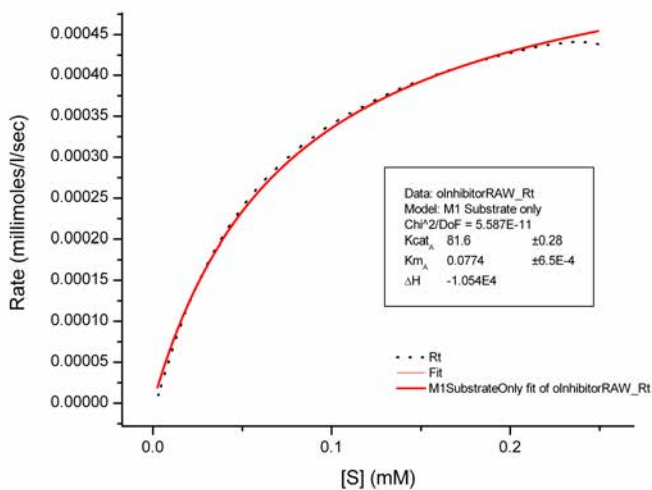

## 6 Data analysis using Origin

### 6.6 Advanced curve fitting

#### 6.6.8 Method 1B: Enzyme assay- substrate plus inhibitor

## 6.6.8 Method 1B: Enzyme assay- substrate plus inhibitor

Open the ITC data file, **M1Inhibitor0175.itc**, as follows:

**Note:** In the presence of an inhibitor  $I$ , it is necessary to enter previously determined values of  $K_{cat}$ ,  $K_M$  and  $\Delta H$  (as determined in the previous example) and use  $K_I$  as the only fitting variable.

- | Step | Action   |
|------|--|
| 1    | Select <b>File:New:Project</b> .<br>A new Origin project opens to display the <b>RawITC</b> plot window.   |
| 2    | Click the <b>Read Data..</b> button.   |
| 3    | Click the drop-down arrow of the <b>Files of type</b> text box and select <b>Enzyme Assay (*.it?)</b> file type.   |
| 4    | Navigate to the <b>C:\Origin70\Samples</b> folder and select <b>M1Inhibitor0175.itc</b> from the <b>File Name</b> list, and click <b>OK</b> .<br>The <b>Enzyme Assay</b> dialog box opens, which allows selection of one of the four models. |

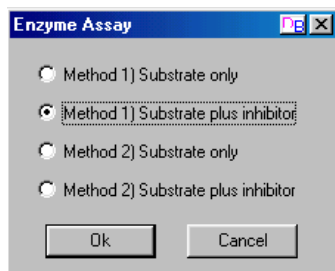

- 5 Select **Method 1) Substrate plus inhibitor** and click **OK**.  
The **Method 1) Substrate plus inhibitor** dialog box opens.

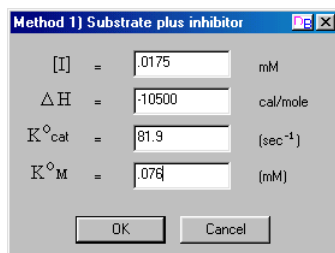

Step	Action
6	<p>Enter .0175 (<b>mM</b>) for <b>[I]</b> inhibitor concentration, -10500 (<b>cal/mole</b>) for <math>\Delta H</math>, as determined in the previous example. Enter 81.9 (<b>sec<sup>-1</sup></b>) for <math>K_{cat}^0</math> and .076 (<b>mM</b>) for <math>K_M^0</math>. Click <b>OK</b>.</p> <p><b>Note:</b> <i>The values for <math>K_M^0</math> and <math>K_{cat}^0</math> may be slightly different depending on where the data is truncated.</i></p>
7	<p>Click the <b>Concentration</b> button. The <b>Concentration</b> dialog box opens. Verify or edit the concentrations.</p>
8	<p>Click the <b>Zero Y Axis</b> button. The cursor turns to a cross hair. Double-click a point, to place at y=0.</p>
9	<p>Click the <b>Apply Time Constant</b> button. The time constant dialog box opens. Verify or edit the time constant for the data.</p>
10	<p>Click the <b>Calculate Rate</b> button. As illustrated in the previous example, the rate is calculated and plotted in a new window versus the concentration of the injectant in the cell.</p>
11	<p>Click the <b>Truncate Data</b> button.</p>
12	<p>Move the data marker to remove the artifact on the right side of the data display, then double-click on one of the markers or press <b>enter</b> to set the point to truncate the curve.</p>
13	<p>Click the <b>Fit to Model</b> button. The <b>Fitting Sessions</b> dialog box opens.</p>
14	<p>Click the <b>200 Iter.</b> button, two or three times, then click <b>Done</b> to end the fitting session. The inhibition constant <math>K_i</math> is used as the variable parameter during the iterative fitting and reported in the output parameter box. The values for the three entered parameters (<math>K_{cat}^0</math>, <math>K_M^0</math> and <math>\Delta H</math>) are also displayed in the parameter box.</p>

## 6.6.9 Method 2A: Enzyme assay- substrate only

### Procedure

To employ Method 2A: Enzyme assay-substrate only, follow the steps described below:

- | Step | Action  |
|------|---|
| 1    | Select <b>File:New:Project</b> .<br>A new Origin project opens to display the <b>RawITC</b> plot window.  |
| 2    | Click the <b>Read Data..</b> button.  |
| 3    | Click the drop-down arrow of the <b>Files of type</b> text box and select <b>Enzyme Assay (*.it?)</b> file type.  |
| 4    | Navigate to the <b>C:\Origin70\Samples</b> folder and select <b>M2NoInhibitor</b> from the <b>File Name</b> list, and click <b>OK</b> .<br>The <b>Enzyme Assay</b> dialog box opens allowing selection of one of the four models. |
| 5    | Select <b>Method 2) Substrate only</b> and click <b>OK</b> .<br>The <b>Method 2) Substrate only</b> dialog box opens.   |
| 6    | Enter <b>-10500</b> (cal/mole) for $\Delta H$ .   |

#### Note:

*In Method 2, the  $\Delta H$  must be independently determined in a separate single-injection experiment (Method 1) and that value should be entered here.*

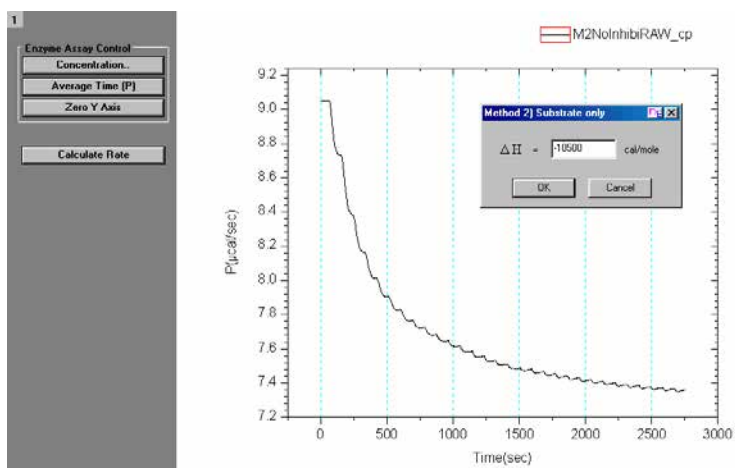



Step	Action
7	Click the <b>Concentration</b> button. The <b>Concentration</b> dialog box opens allowing to verify or edit the concentrations.

## Average time (P)

### Power level

The rate of substrate decomposition reactions are determined by measuring the change in the power output in the calorimeter cell that results after each addition of the substrate. The new power level is determined by averaging the power level for a specified time prior to the next injection. After each injection, allow enough time for the instrument to equilibrate at the new power level, but not so much time that significant hydrolysis of substrate occurs. A default value of 15 s is entered for the time period to average the power signal before each injection. However, this default value can be changed as required by a particular substrate.

### Changing the time period to average the power signal

To change the time period to average the power signal before each injection, follow the steps described below:

Step	Action
1	Click the <b>Average Time (P)</b> button. A dialog box opens that allows the user to change or accept the default value of 15 s.

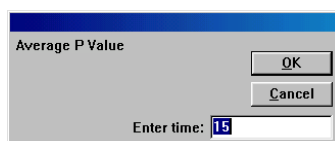

- Click **OK** to accept 15 s for average the power level.
- Click the **Zero Y Axis** button.  
The cursor will turn to a cross hair.
- Double-click a point, to place at  $y=0$ .

## 6 Data analysis using Origin

### 6.6 Advanced curve fitting

#### 6.6.9 Method 2A: Enzyme assay- substrate only

Step	Action
------	--------

5	Click the <b>Calculate Rate</b> button.
---	---

As illustrated in the previous examples, the rate will be calculated and plotted in a new window versus the concentration of the injectant in the cell.

**Note:**

*This example does not need the **Truncate Data** nor the **Apply Time Constant** buttons.*

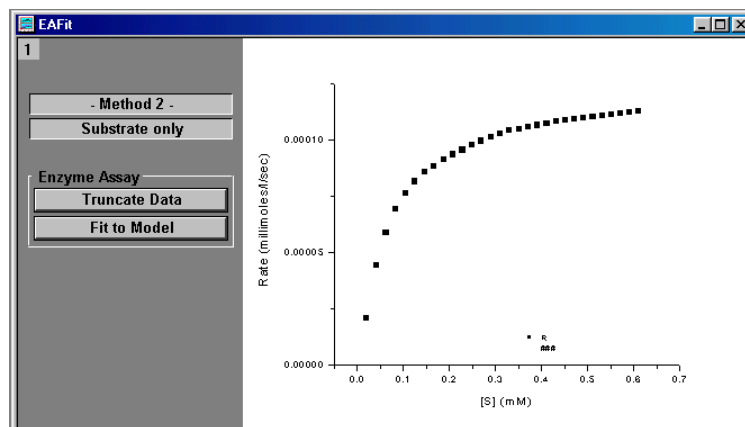

6	Click the <b>Fit to Model</b> button.
---	---------------------------------------

The **Fitting Sessions** dialog box opens.

7	Click the <b>200 Iter.</b> button, one or two times.
---	--

8	Click <b>Done</b> to end the fitting session.
---	---

$K_{cat}$  and  $K_m$  are used as the variable parameters during the iterative fitting process and, along with the entered  $\Delta H$ , are reported in the output parameter box.

Data:	M2NoInhibi_R
Model:	M2SubstrateOnly
Chi <sup>2</sup> /DoF	= 2.129E-12
$K_{cat}$	67.8 $\pm 0.423$
$K_m$	0.084 $\pm 0.00219$
$\Delta H$	-1.050E4

## 6.6.10 Method 2B: Enzyme assay- substrate plus inhibitor

To employ Method 2B: Enzyme assay-substrate plus inhibitor, follow the steps described below:

- | Step | Action  |
|------|---|
| 1    | Select <b>File:New:Project</b> .<br>A new Origin project opens and displays the <b>RawITC</b> plot window.  |
| 2    | Click the <b>Read Data..</b> button.  |
| 3    | Click the drop-down arrow of the <b>Files of type</b> text box and select <b>Enzyme Assay (*.it?)</b> file type.  |
| 4    | Navigate to the C:\Origin70\Samples folder and select <b>M2NoInhibitor</b> from the <b>File Name</b> list, and click <b>OK</b> .<br>The <b>Enzyme Assay</b> dialog box opens and allows selection of one of the four models.                                    |
| 5    | Select <b>Method 2) Substrate plus inhibitor</b> and click <b>OK</b> .<br>The <b>Method 2) Substrate plus inhibitor</b> dialog box opens.   |
| 6    | Enter 0.01 (mM) for <b>[I]</b> inhibitor concentration, -10500 (cal/mole) for <b><math>\Delta H</math></b> , as determined in the previous example. Enter 67.8 ( $\text{sec}^{-1}$ ) for <b><math>K_{cat}</math></b> and 0.084 mM for <b><math>K_M</math></b> . |

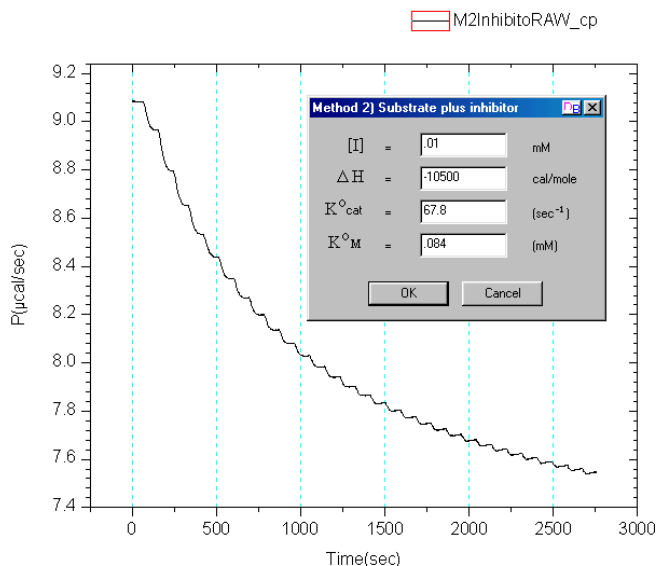

## 6 Data analysis using Origin

### 6.6 Advanced curve fitting

#### 6.6.10 Method 2B: Enzyme assay- substrate plus inhibitor

Step	Action
7	Click the <b>Zero Y Axis</b> button. The cursor turns to a cross hair.
8	Double-click a point, to place at $y=0$ .
9	Click the <b>Calculate Rate</b> button. As illustrated in the previous example, the rate is calculated and plotted in a new window versus the concentration of the injectant in the cell.  <b>Note:</b> <i>Method 2 does not need to use the <b>Truncate Data</b> button.</i>
10	Click the <b>Fit to Model</b> button. The <b>Fitting Sessions</b> dialog box will open.
11	Click the <b>200 Iter.</b> button, one or two times.
12	Click <b>Done</b> to end the fitting session. $K_i$ is used as the variable parameter during the iterative fitting and reported in the output parameter box and should have a value near 0.0076 mM.

## 6.6.11 Dimer dissociation model

### Introduction

This model is intended for the analysis of heats of dilution data where the sample compound in the syringe has a tendency to form dimers, i.e.,



$$K = \frac{[P]^2}{[P_2]}$$

Multiple injections are made from the syringe and the resulting heats analyzed to give best values for the dissociation constant K, and the heat of dissociation,  $\Delta H$ .

### Fitting data using the dimer dissociation model

To fit data using the dimer dissociation model, follow the steps described below:

- | Step | Action   |
|------|--|
| 1    | Select <b>File:New:Project</b> .<br>A new Origin project opens and displays the <b>RawITC</b> plot window.       |
| 2    | Click the <b>Read Data..</b> button.   |
| 3    | Click the drop-down arrow of the <b>Files of type</b> text box and select <b>Dissociation (*.it?)</b> file type. |

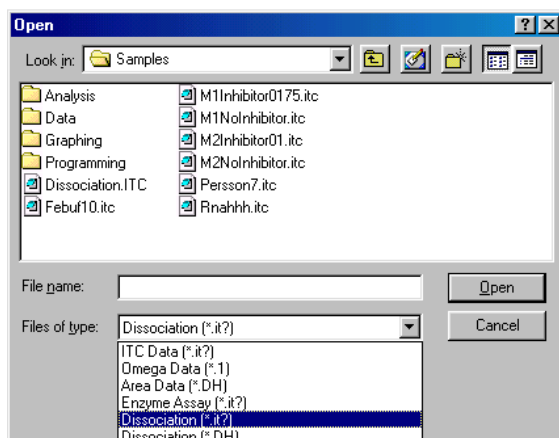

## 6 Data analysis using Origin

### 6.6 Advanced curve fitting

#### 6.6.11 Dimer dissociation model

Step	Action
------	--------

- |   |  |
|---|--|
| 4 | Navigate to the <code>C:\Origin70\Samples</code> folder and select <b>Dissociation.ITC</b> from the <b>File Name</b> list, and click <b>OK</b> . |
|---|--|

Similar to the normal ITC files, the dissociation file is read and plotted as a line graph in the **RawITC** window, in units of  $\mu\text{cal}/\text{second}$  versus minutes. Origin then automatically performs the following operations:

- 1 Selects **Auto Baseline** routine. Each injection peak is analyzed and a baseline is created.
- 2 Selects **Integrate All Peaks** routine. The peaks are integrated and the area ( $\mu\text{cal}$ ) under each peak is obtained.
- 3 Opens the **DeltaH** window. The difference for this model is that Origin then plots the normalized area ( $\text{kcal}/\text{mole}$  of monomer) versus equivalent monomer concentration (mM).

**Note:**

*Equivalent monomer concentration represents the total monomer units in the cell. It is not the free monomer concentration.*

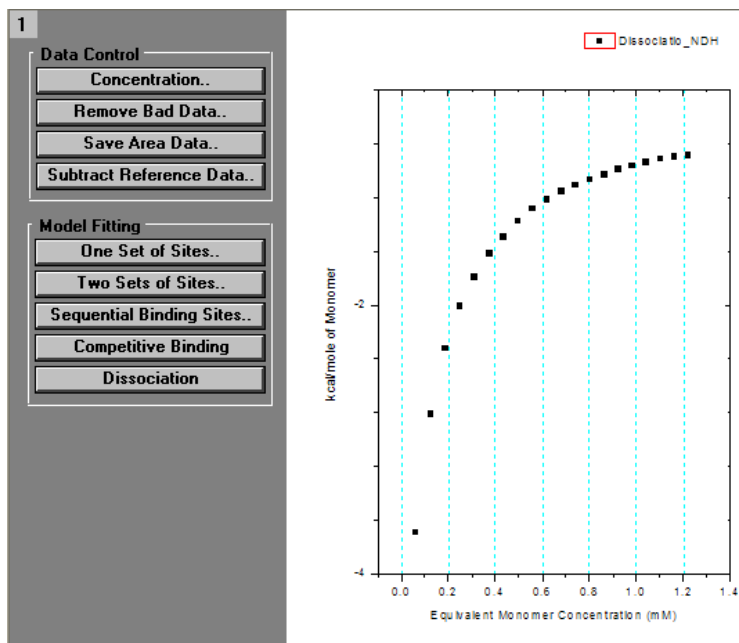

**Step Action**

- 5 Check the concentration in the syringe.  
 This concentration must always be entered as equivalent monomer concentration. In this case, the concentration is correctly entered and stored in the data file. Click **OK** or **Cancel**.

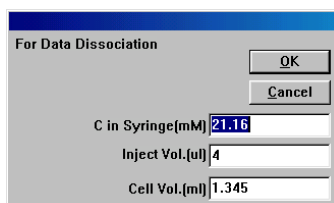

- 6 Click the **Concentration** button.  
 In this case, the concentration is correctly entered and stored in the data file.
- 7 Click **OK** or **Cancel**.
- Note:**  
*Unlike typical ITC files, concentration of macromolecule need not be entered, since it is 0.*
- 8 Click the **Dissociation** button.  
 The **NonLinear Curve Fitting: Fitting Session** dialog box for the dissociation model opens.
- 9 Click the **200 Iter.** button one or two times to make sure that Chi-square is no longer decreasing and then click **OK**.  
 The fitting parameters should be similar to those displayed below.

Data: Dissociatio NDH  
 Model: Dissociation  
 Chi<sup>2</sup> = 0.1881  
 DH (cal/mole)            -9994 ±16.7  
 K (mM)                    0.623 ±0.0037

## 6.6.12 Competitive ligand binding

### Introduction

Competitive binding experiments are carried out by injecting a strongly binding ligand A into a solution that contains both the macromolecule and the competing ligand B. The ligand A appears to bind more weakly to the macromolecule in the presence of the competing ligand B than when present alone. In order to perform curve-fitting on results from a competitive binding experiment, a second non-competitive experiment must first be carried out in the conventional way to determine the binding parameters for ligand B ( $N_B$ ,  $K_B$  and  $\Delta H_B$ ) itself. These three parameters are used as input allowing  $N_A$ ,  $K_A$  and  $\Delta H_A$  to be determined from results of the competitive experiment.

### Designing a competitive experiment

When designing a competitive experiment, the total concentration of the competing ligand,  $[B]_{tot}$ , should be selected so that

$$\frac{K_A}{K_B[B]_{tot}} \cong 10^5 - 10^8 M^{-1}$$

where " $K_A$ " is the estimated value of  $K_A$ . This insures that the apparent binding constant in the competitive experiment will be in the best "window",  $10^5$  to  $10^8 M^{-1}$ , to be easily measured by ITC.

### Fitting data using the competitive ligand binding model

To fit data using the competitive ligand binding model, follow the steps described below:

**Note:** *In the following example, results from a conventional, non-competitive experiment have already been analyzed to obtain the parameters  $N_B=0.993$ ,  $K_B=21600 M^{-1}$  and  $\Delta H_B=-11700 cal/mole$ . The data from the competitive experiment have been saved in an area data file named **Competitive.DH**, which will be analyzed below.*

Step	Action
------	--------

- |   |  |
|---|--|
| 1 | Select <b>File:New:Project</b> .<br>A new Origin project opens to display the <b>RawITC</b> plot window. |
| 2 | Click the <b>Read Data..</b> button.   |



- | Step | Action  |
|------|---|
| 3    | Click the drop-down arrow of the <b>Files of type</b> text box and select <b>Area Data (*.DH)</b> file type.  |
| 4    | Navigate to the <code>c:\Origin70\Samples</code> folder and select <b>Competitive.DH</b> from the <b>File Name</b> list, and click <b>OK</b> .<br>The <b>Competitive.DH</b> file opens, the data are normalized on concentration and plotted in the <b>DeltaH</b> window. |

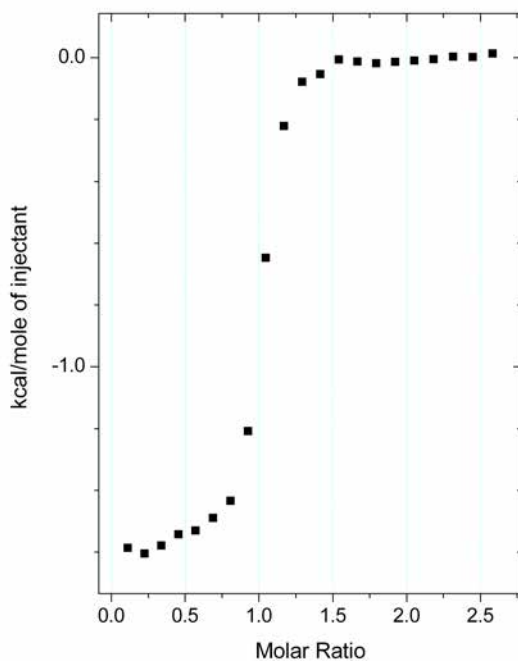

## 6 Data analysis using Origin

### 6.6 Advanced curve fitting

#### 6.6.12 Competitive ligand binding

Step	Action
------	--------

- |   |   |
|---|---|
| 5 | Click the <b>Competitive Binding</b> button.<br>The <b>Competing Ligand</b> dialog box opens. |
|---|---|

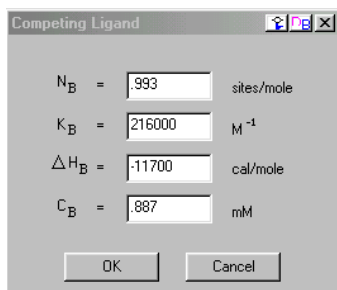

The image shows a dialog box titled "Competing Ligand" with the following parameters:

$N_B$	=	.993	sites/mole
$K_B$	=	216000	$M^{-1}$
$\Delta H_B$	=	-11700	cal/mole
$C_B$	=	.887	mM

Buttons: OK, Cancel

- |   |   |
|---|---|
| 6 | Enter the following values obtained from the first experiment $N_B = 0.993$ , $K_B = 216000$ , $\Delta H_B = -11700$ and $C_B = 0.887$ and then click <b>OK</b> .<br>The <b>NonLinear Curve Fitting: Fitting Sessions</b> dialog box for the competitive binding model opens. |
| 7 | Click the <b>200 Iter.</b> button one or two times to make sure that Chi-square is no longer decreasing and then click <b>OK</b> .  |

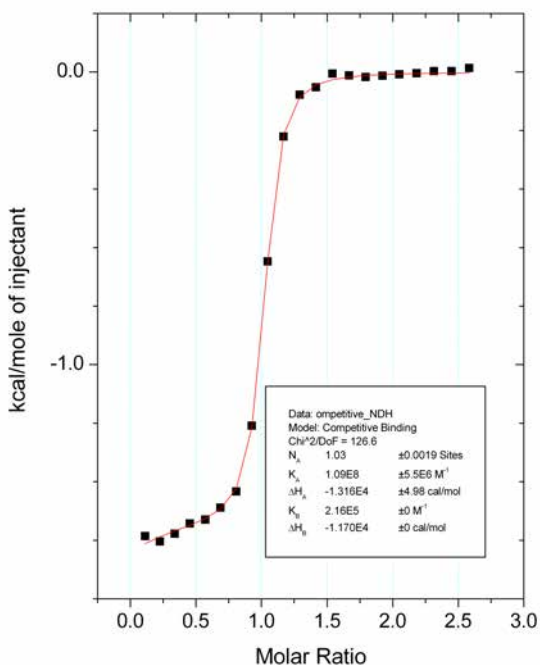

## 6.6.13 Simulating curves

### Introduction

Titration experiments can be simulated without actually going through the fitting routine. The simulated curve may or may not be related to actual data obtained. To simulate data, there must be some ITC results in computer memory (either raw data called up, or an Origin project that contains data) but these results need not be related to the simulations carried out. The data in memory should contain at least as many data points (or number of injections) as the curve to be simulated.

**Note:** For proper simulation, use a data file that has all injections of the same volume. Do not use a file that has a preliminary first injection of a different size.

### Simulating a fit curve

To simulate a fit curve, follow the steps described below:

Step	Action
1	Exit the fitting session and start a new project by selecting <b>File:New:Project</b> (or click on the <b>New Project</b> button) from the menu.
2	Click the <b>Read Data..</b> button in the <b>RawITC</b> window.
3	Select <b>ITC Data (*.ITC)</b> from the <b>List Files As</b> type box.
4	Open the <b>Rnahhh.ITC</b> data file located in the C:\Origin70\Samples folder. The <b>DeltaH</b> window becomes the active window.
5	Click the <b>Concentration..</b> button in the <b>DeltaH</b> window.
6	Change the concentrations and injection volume values to those desired for the simulation. For this example, set concentration in syringe to 3, concentration in cell to .2.

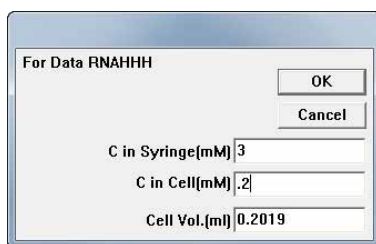

## 6 Data analysis using Origin

### 6.6 Advanced curve fitting

#### 6.6.13 Simulating curves

- | Step | Action  |
|------|---|
| 7    | Click <b>OK</b> .   |
| 8    | Click the <b>Two sets of Sites</b> button from the model fitting box.<br>The fitting session dialog box opens with the <b>Two Sets of Sites</b> model selected.   |
| 9    | Enter the following parameters in the parameters text boxes:<br><b><math>n1 = 1</math>, <math>K1 = 1e7</math>, <math>H1 = 10000</math>, <math>n2 = 1</math>, <math>K2 = 1e5</math>, <math>H2 = -10000</math>.</b> |
| 10   | Click the <b>Chi-Sqr</b> button.<br>The simulated curve <b>YFIT</b> appears in the <b>DeltaH</b> window.  |

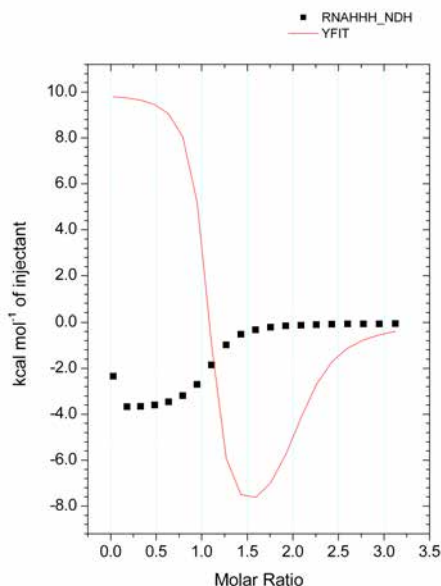

#### Note:

Do not click on the **1 Iter.** or **200 Iter.** buttons or the parameters will be changed.

#### Tip:

The original data subtracts from the simulated data, but this data is required to be in memory for simulated data. This data cannot be deleted but can be hidden from view. Right-click directly on any of the square data points of the RNAHHH\_NDH curve and select **Hide**.

Step	Action
11	<p>Right-click on the simulated data trace and select <b>Change to Line + Symbol</b>.</p> <p><b>Note:</b> <i>The simulated data has twenty data points just as the original Rnahhh curve. Also it appears that the simulated curve has not leveled due to complete binding. This can be corrected by clicking the <b>Concentration..</b> button to increase the concentration in the syringe, decrease the concentration in the cell or increase the volume of the injection. Alternatively, start over and read in a data set with more data points (or injections).</i></p>
12	<p>Select <b>Window:DeltaH</b> and click the <b>Concentrations</b> button. Enter 0.2 mM for the concentration in the cell.</p> <p>The graph rescales on the x-axis, but the simulated curve will not be affected until the <b>Chi-Sqr</b> button is clicked again.</p>
13	<p>Click the <b>Chi-Sqr</b> button.</p> <p>The curve is simulated using the new concentration.</p>

## 6.6.14 Single injection method (SIM)

### Introduction

The MicroCal iTC<sub>200</sub> is also capable of carrying out a complete binding experiment using only a single, continuous injection, as opposed to the normal procedure that requires multiple injections. In this single injection procedure, only one slow, continuous injection of titrant solution is made into the cell material.

**Note:** *The binding parameters obtained from a well designed multiple injection experiment usually have higher degree of accuracy than the single injection experiment. If the sample turnover rate is not a prime concern, perform the multiple injection experiment for more precise binding parameters.*

---

### Automated steps performed before analysis

Data is corrected using the instrument's time constant.

The corrected data set is filtered using the standard Fourier transform filter in Origin 7.0 and a bandwidth of 15 data points.

Perform the following actions:

Step	Action
1	Zero the baseline from which the experimental data is to be subtracted (see <i>Zeroing the baseline</i> , on page 241).
2	Exclude distorted or extraneous data points prior to subsequent analysis.

---

### Creating a new worksheet

The raw data (after time constant correction, Fourier filtering, baseline subtraction, and eliminating inappropriate data) can then be used to form a new worksheet, which is modeled after the existing worksheet used with multi-injection binding data.

---

## Creating *SIM ITC* icon on the desktop

To create a ***SIM Analysis*** icon on the desktop, follow the steps described below:

Step	Action
1	Right-click any Origin 7 icon on the desktop.
2	Select <b>Copy</b> , right-click on desktop and select <b>Paste</b> to create a copy of Origin 7 icon.
3	Right-click the copy of the icon, select <b>Rename</b> , and enter <i>SIM ITC</i> to re-name the icon.
4	Right-click the <b><i>MicroCal SIM AnalysisC</i></b> icon, select <b>Properties</b> . In <b>Target</b> window, change the final number of target to 8, and click <b>OK</b> to change the target of the desktop icon to <i>SIM</i> .

## Input SIM data

To input SIM data, follow the steps described below:

Step	Action
1	Double-click the <b><i>MicroCal SIM Analysis</i></b> icon on desktop.

6 Data analysis using Origin  
6.6 Advanced curve fitting  
6.6.14 Single injection method (SIM)

**Step**      **Action**

- 2 Click the **Read Data** button in the **Single Injection** group.



The import multiple ASCII **Open** dialog box opens. The only option for **Files of type** is **ITC Data (\*.sim or \*.itc)**.

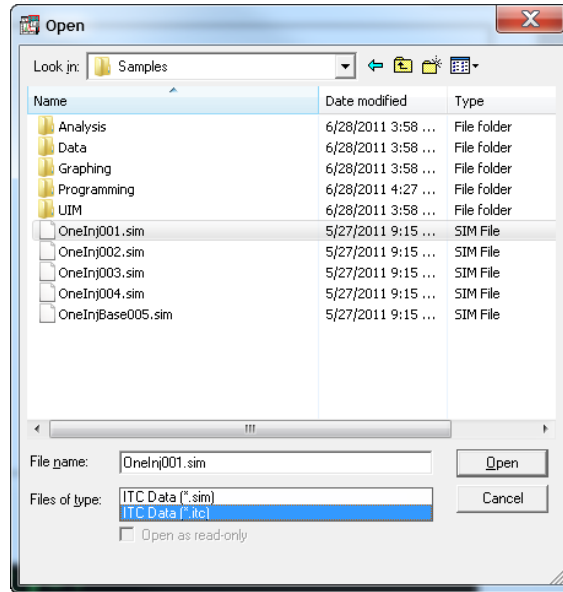

- 3 Navigate to the **c:\Origin70\Samples** folder and select **OneInj001.sim** from the files list.



**Step Action**

- 4 Click **Open**.
- The file is then read in and the following operations are executed on the data set:
- 1 The data is read into a worksheet that is created with the corresponding name and RAW appended (i.e., the worksheet is named **OneInj001RAW**).
  - 2 The time before the injection starts (60 s) is subtracted from the x data so that the injection starts at t=0 and all data points are shifted to the left.
- Note:**
- The x data before t=0 is removed from the worksheet, but the data is still plotted in the graph for use in baseline subtraction.*
- 3 The data is corrected for the time constant of the instrument.
  - 4 The noise introduced by the time constant correction is filtered using the standard Fourier transform filter of Origin and a bandwidth of 15 data points.
  - 5 The corrected and filtered data is then plotted in the **ARawITCsi** window.

## Zeroing the baseline

**Subtract Options**

Clicking on the **Subtract Options** button opens the **Control Baseline Subtraction** window, which displays the following options:

Button	Function
<b>Input final numerical Y position</b>	Clicking this button prompts for a final Y position (in $\mu\text{cal}/\text{sec}$ ). The end point of plotted data set is placed at that position and the rest of the data set is offset proportionately. Typically 0 is used as the final Y position.  <b>Note:</b> <i>Use this button for fast data reduction.</i>
<b>Subtract a constant</b>	Clicking this button prompts for a constant ( $\mu\text{cal}/\text{sec}$ ) that will be subtracted from all data sets plotted in the <b>ARawITCsi</b> graph.

## 6 Data analysis using Origin

### 6.6 Advanced curve fitting

#### 6.6.14 Single injection method (SIM)

Button	Function
<b>Subtract reference data</b>	Clicking this button allows the heats from the control experiment to be subtracted from the data set that is plotted in the <b>ARawITCsi</b> graph.  <b>Note:</b> <i>Data set from a control experiment is required.</i>
<b>Y axis shift</b>	Clicking this button changes the cursor to the data reader tool. Click once to see the y-axis position of the data reader tool. Double-click or press <b>enter</b> to move the end point of the data set to that y position.
<b>Straight line</b>	Clicking this button changes the cursor to the data reader tool. Double-click at the point on the graph where the line should begin, and double-click again at the point where the line should end. A straight line is created between the two points and extrapolated to be subtracted from all data points.  <b>Note:</b> <i>Use this button when baseline is not horizontal.</i>

The baseline can be set to zero by following either of the two recommended methods described below:

#### Method 1:

Step	Action
------	--------

- |   |   |
|---|---|
| 1 | Click the <b>Subtract Options</b> button from the <b>Single Injection</b> group of buttons. The <b>Control Baseline Subtraction</b> dialog box pops up. |
|---|---|

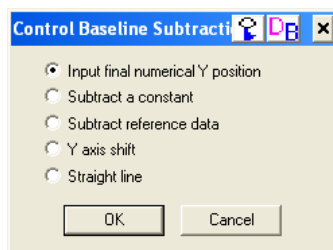

- |   |   |
|---|---|
| 2 | Select <b>Straight line</b> option. The cursor changes to the data reader tool. |
|---|---|

- | Step | Action   |
|------|--|
| 3    | Double-click the data reader tool near the end of the curve (about 30 min) and double-click again on the curve at 0 min.<br>Origin quickly creates a straight line, which is extrapolated and subtracted from all data points, as shown below. |

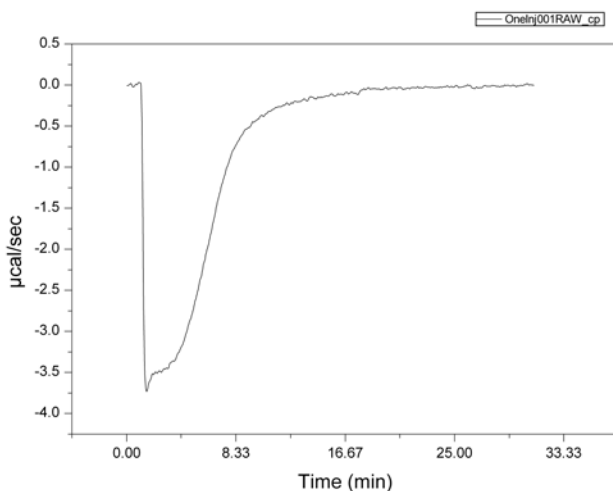

#### Method 2:

- | Step | Action  |
|------|---|
| 1    | Click the <b>Read Data</b> button   |
| 2    | Re-open the <b>OneInj001.sim</b> data file.   |
| 3    | Click the <b>Subtract Options</b> button and select <b>Input final numerical Y position</b> option. |
| 4    | Enter 0 in <b>Value</b> window.   |

Step	Action
------	--------

- |   |  |
|---|--|
| 5 | Click <b>OK</b> .<br>A plot similar to the one shown below is displayed. |
|---|--|

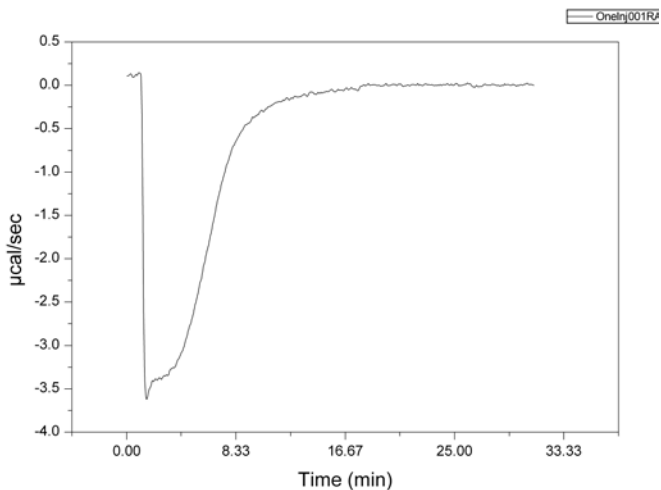

## Removing bad data

### Introduction

Data at the beginning of the experiment might be distorted when the time constant is corrected and there may be extraneous data points after the injection is complete. The

**Remove Bad Data...** button  simplifies the task of excluding these data points from subsequent analysis. At the start of the injection, typical experiments exhibit a high point (exothermic reaction) or a low point (endothermic reaction).

### Options in the *Remove Bad Data* window

Clicking the **Remove Bad Data...** button opens the **Remove Bad Data** window. This window displays the following options:

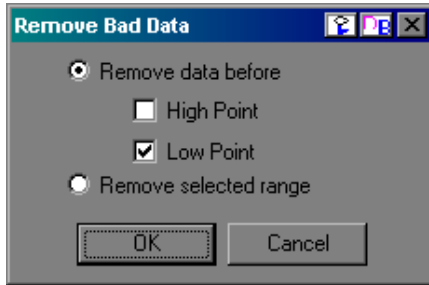

Option	Function
<b>Remove data before</b>	<p>This option allows selection of either <b>High Point</b> or <b>Low Point</b>.</p> <p>Origin searches each data set and deletes all data before the corresponding high or low point in the data. The data is then plotted on the graph with the beginning data point removed.</p>
<b>Remove selected range</b>	<p>Each data set is sequentially plotted on the graph with two data markers displayed on the trace.</p> <p><b>Tip:</b> Click and drag on a marker to move it to the desired point on the trace, then double-click or press <b>enter</b> to set the point. All data between the two markers will be removed from the graph and eliminated from future analysis.</p> <p><b>Tip:</b> When moving a data marker, press the space bar to increase the size of the cross-hair.</p>

### Removing bad data

To remove bad data, follow the steps described below:

Step	Action
1	Click the <b>Remove Bad Data...</b> button from the <b>Single Injection</b> group.
2	Select the <b>Remove data before</b> option and checkmark the <b>Low Point</b> box.

Step	Action
------	--------

- |   |   |
|---|---|
| 3 | Click <b>OK</b> .<br>A graph similar to one shown below is plotted. |
|---|---|

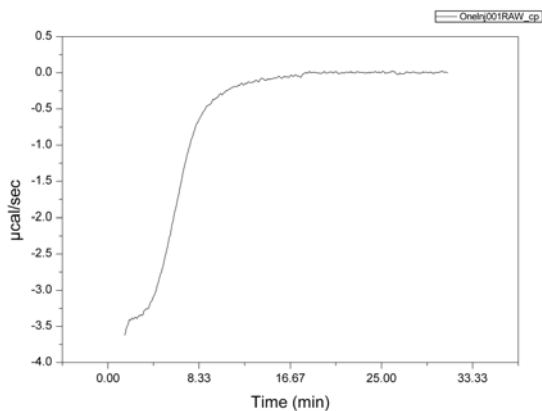

## Normalizing data points

To normalize data points, click the **Normalize Data** button  from the **Single Injection** group.

The concentration is calculated and the normalized heat is plotted in a new window, named **DeltaH**. The data is now in the form of conventional ITC normalized data and may be fit with the **One Set of Sites** or **Two Sets of Sites** methods previously described in section 6.6).

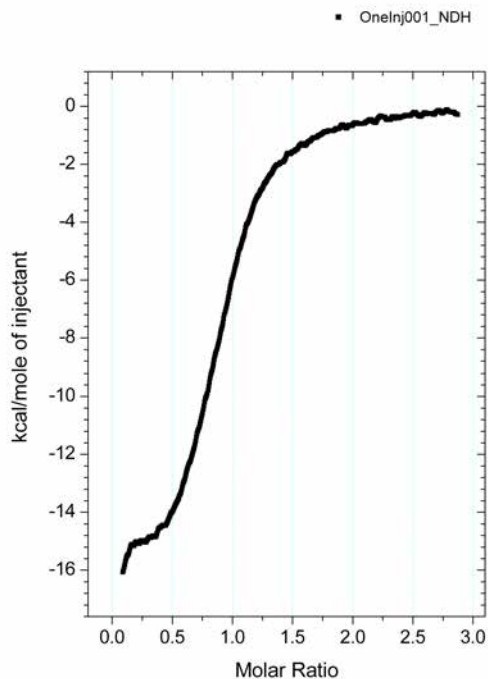

## 6.7 Other useful details

### Chi-square (Chi<sup>2</sup>) minimization

The aim of the fitting procedure is to find those values of the parameters that best describe the data. The standard way of defining the best fit is to choose the parameters so that the sum of the squares of the deviations of the theoretical curve(s) from the experimental points for a range of independent variables is at a minimum.

For ITC models where there is no weighting, the theoretical models can be represented by:

$$y = f(x; p_1, p_2, p_3, \dots)$$

where:

$p_i$  = the fitting parameters

Hence, the expression for  $\chi^2$  simplifies to:

$$\chi^2 = \frac{1}{n^{eff} - p} \sum [y_i - f(x_i; p_1, p_2, \dots)]^2$$

where:

Parameter	Description
$n^{eff}$	the total number of experimental points used in the fitting
$p$	total number of adjustable parameters
$y_i$	experimental data points
$f(x; p_1, p_2, p_3, \dots)$	fitting function

**Note:** The difference  $d = n^{eff} - p$  is usually referred to as the number of degrees of freedom.

The above equation states that the Chi-squared value of the fit is equal to the sum of the squares of the deviations of the theoretical curve(s) from the experimental points divided by the number of degrees of freedom. Since there is no weighting, it can be seen that the calculated values are dependent on the magnitude of the scale and the number of data points. After fitting, this value is reported as Chi<sup>2</sup>/DoF.

### Line types for fit curves

#### Plot Details dialog box

To open the **Plot Details** dialog box, follow the steps described below:



Step	Action
1	Double-click on the data plot.
2	Right-click on the data plot and select <b>Plot Details</b> from the shortcut menu. Alternatively, select the desired data plot from the <b>Data</b> menu data list and select <b>Format:Plot</b> .

### The line group

Select the desired line connection from the associated **Connect** drop-down list. The line connection type affects the interpolation results. The default line type for fit curves is straight line.

The most common methods of connecting the fit curve data points are described below:

Line type	Description
<b>Straight</b>	A straight line is displayed between the data points. This type of line connection will not give a smooth representation of the fit curve if there are only a few data points.
<b>Spline</b>	<p>This option generates a cubic spline connection. To use the connection, the X values must be discrete and increasing. Furthermore, the number of data points cannot exceed 900. The operation fails if the data set exceeds this number.</p> <p>Since the curvature information is held in memory, the spline resolution remains the same regardless of the page magnification. The <b>SplineStep</b> variable in the <b>ORIGIN.INI</b> file controls the spline calculation increment. It is expressed in units of .1 point. This is usually the most satisfactory representation of the fit curve, but may exhibit an excursion from the actual fit curve if there is a sharp corner in the data.</p>
<b>B-Spline</b>	The B-spline curve can be described by parametric equations. Unlike spline curves, which pass through the original data points, the B-spline curve winds around the original data points without passing through them. Thus, this curve may not produce a satisfactory representation of the fit curve. For a complete discussion of the B-spline connection, see <i>Origin User's Manual</i> .

## View mode

### Introduction

Each Origin plot window can be viewed in any of four different view modes:

## 6 Data analysis using Origin

### 6.7 Other useful details

- **Print View**
- **Page View**
- **Window View**
- **Draft View**

These are available under the **View** menu option.

#### Print view

**Print View** is a true WYSIWYG (What You See is What You Get) view mode. This view mode displays a page that corresponds exactly to the page from the hard copy device. Exact font placement and size is guaranteed, but with some sacrifice to screen appearance, since the printer driver fonts must be scaled to fit their positions on the page (this will not harm the appearance of true vector fonts). This is a slow process, and screen refresh speed suffers as a result. Thus, reserve the **Print View** mode for previewing the work prior to printing.

**Note:** *Origin automatically changes to **Print View** mode when graphics are exported to another application and when printing. The view mode automatically returns to the selected view mode after the operation is complete.*

#### Page view

**Page View** provides faster screen updating than **Print View**, but does not guarantee exact text placement on the screen unless typeface scaling software (such as **Adobe Type Manager**) is being used. Use **Page View** mode until the application is ready for printing or copying to another application. Change to **Print View** mode to check object placement before exporting, copying, or printing.

#### Window view

**Window View** expands the page to fill up the entire graph window.

**Note:** *Labels, buttons, or other objects in a graph window that reside in the gray area of the page are not visible in **Window View** mode.*

#### Draft view

**Draft View** has the fastest screen update of the four view modes. In **Draft View**, the page automatically sizes to fill the graph window. This is a convenient mode to use when looking at on-screen data is the primary focus. **Draft View** is the fastest view mode, and is very useful when precise formatting is not required.

**Note:** *The type of view mode will not affect the print-outs, but only on-screen display will be affected.*

---

## Inserting an Origin graph into Microsoft Word

There are two ways to include the Origin graph into Microsoft Word (or other applications), either import the graph into Word or link (share) the graph to Word. When importing the graph, Word displays the graph as an object and it cannot be edited by Origin tools (although it may be resized or repositioned in the Word document). When linking (share) the graph, Word displays the graph as an object, which can be edited by Origin and updated when the Origin graph changes.

Please refer to the Origin manual for more information about creating a graphical presentation.

### Importing the graph into Microsoft Word

To import the graph into Word, follow the steps described below:

Step	Action
1	Create the graph in Origin and select <b>Edit:Copy Page</b> .
2	Open the Word document and click at the location where the graph should be placed.
3	Select <b>Edit:Paste Special</b> .
4	Select <b>Origin Graph Object</b> from the <b>As:</b> list box.
5	Select the <b>Paste Link</b> radio button.
6	Click <b>OK</b> .

### Linking the graph to Microsoft Word

To link the graph to Word, follow the steps described below:

Step	Action
1	Create the graph in Origin and then save it as part of an Origin project ( <b>*.OPJ</b> ).
2	Open the saved Origin project (if it is not already open) that includes the desired graph window.
3	Make the desired graph window active, and select <b>Edit:Copy Page</b> .
4	Open the Word document and click at the location where the graph needs to be inserted.
5	Select <b>Edit:Paste Special</b> .
6	Select <b>Origin Graph Object</b> from the <b>As:</b> list box
7	Select the <b>Paste Link</b> radio button.

## 6 Data analysis using Origin

### 6.7 Other useful details

Step	Action
------	--------

8	Click <b>OK</b> .
---	-------------------

After the Origin graph is linked to Word, return to the original Origin graph and make changes to the graph. These changes can be reflected in the Word document by selecting **Edit:Update Client** from the Origin menu.

**Tip:** Start Origin and load the linked graph by simply double-clicking on the graph while in Word. Origin starts with the original document loaded, and the changes can be made by selecting **Edit:Update Client**. The changes are automatically reflected in the Word document.

# 7 Maintenance

## Introduction

This chapter provides information about the maintenance of the instrument. Regular maintenance by the user of the MicroCal iTC<sub>200</sub> instrument is essential for quality experiments and results. The maintenance tasks described below are listed roughly in the order of their required frequency. Also, it is recommended that the instrument be shut down when not in use (**Power** switch in the rear).

---

## In this chapter

This chapter contains the following sections:

Section	See page
7.1 Cleaning the cell	254
7.2 Refilling the reference cell	255
7.3 Washing module	256
7.4 Replacing the syringe plunger tip	261
7.5 Replacing and cleaning the titration syringe	268

---

## 7.1 Cleaning the cell

### Introduction

Cleanliness of the cell has a significant impact on data quality. A dirty cell typically manifests itself in poor loading of the cell (a low baseline position). For a description of washing procedures, see *Section 8.4 Upward stepping baseline, on page 284* and *Section 8.7 Low baseline, on page 288*. Also, see *Section 5.3 Cleaning the cell and syringe before performing an experiment, on page 103*.

---

### Basic cleaning

The most basic cleaning procedure using detergent (20% Contrad 70™ (or 14% Decon 90™) in deionized water) involves briefly soaking the cell with detergent and then flushing with water. It is recommended that this is performed as often as every run, and especially if poor data is collected.

---

### Extra Clean

An aggressive cleaning procedure entails loading the cell with detergent, raising the cell temperature to 60°C, soaking for one hour, and then rinsing the cell with water. It is recommended that this is performed weekly or if poor data is collected.

---



#### **WARNING**

Always use appropriate personal protective equipment (PPE) during cleaning and maintenance of the equipment.

## 7.2 Refilling the reference cell

### Introduction

The MicroCal iTC<sub>200</sub> has two cells, the sample cell and the reference cell. The reference cell must be refilled manually, approximately once a week. An underfilled reference cell can manifest itself as a starting baseline position *greater* than specified in the ITC Method.

---

### Procedure

To refill the reference cell, follow the steps described below:

Step	Action
1	Gently insert the glass Hamilton syringe into the right reference cell until it touches the bottom.
2	Suck out the liquid completely by pulling up the syringe plunger. <b>Note:</b> <i>Make sure no bubbles are trapped in the cell.</i>
3	Remove and empty the syringe. Clean the syringe, if necessary.
4	Pull approximately 300 $\mu$ l of degassed, distilled water into the syringe. Tap the syringe glass gently so that all the bubbles are at the top volume of the syringe.
5	Insert the syringe into the cell and gently touch the bottom of the cell with the tip of the syringe needle. Raise the needle tip about 1 mm off the bottom of the cell, and hold it there until finished filling. <b>Note:</b> <i>Make sure not to raise the syringe during the filling process.</i>
6	Inject the solution slowly into the cell until it spills out the top of the cell stem. Dislodge any trapped bubbles with several abrupt spurts of the solution. <b>Note:</b> <i>Make sure no bubbles are transported into the reference cell while loading the solution.</i>
7	Lift the tip of the syringe to the cell port (just below the visible portion of the cell port) and remove the excess solution.
8	Remove the syringe. Install the reference cell plug to prevent evaporation.

---

## 7.3 Washing module

### Bottle removal

Use this procedure to remove the bottles for cleaning. The lines to the bottles need to be evacuated before the tubing is disconnected from the wash station. This will make sure no solution leaks from the disconnected tubing.

Step	Action
------	--------

- |   |  |
|---|--|
| 1 | Disconnect the tubing from the bottle while leaving the other end attached to the system and place the disconnected ends in a clean, empty beaker. |
|---|--|



- |   |  |
|---|--|
| 2 | Click <b>Cell Buffer Rinse (Short)</b> .   |
| 3 | Follow the instructions on the screen.   |
| 4 | Click <b>Syringe Wash (Long)</b> .   |
| 5 | Follow the instructions on the screen.   |
| 6 | Remove the tubing from the bottle(s) by twisting the Luer lock fitting counterclockwise. |
| 7 | Perform the filling of the bottle(s).  |
| 8 | Secure the bottle(s).  |
| 9 | Install the tubing to the bottles by twisting the Luer lock fitting clockwise.           |

**Note:**

*Do not over tighten.*

---

Refer to *Priming tubing*, on page 28 before performing normal operations.



## Replacing the cleaning tool tubing

Use this procedure to replace the tubing connecting the cell cleaning tool and the syringe washing tube if it has been contaminated or damaged. A kit (KIT020599), supplied as an accessory, contains tubing for the cell wash tool, waste bottle, and the syringe washing tube. The filling port adapter (ASY020506) and associated tubing can be ordered from Malvern Instruments.

### Cell Cleaning Tool

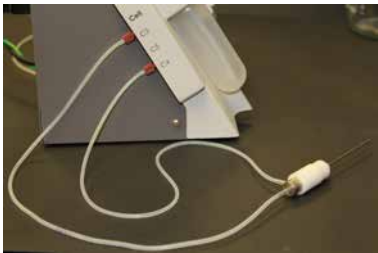
Step	Action
1	Remove the tubing from the extra tubing kit and locate the three equal length pieces.
2	Set one tube aside for the syringe cleaning vial.
3	Remove the tube between the washing module and the top of the Cell Cleaning Tool. This is the tube that extrudes vertically from the cell cleaning tool.
	
4	Install the replacement tube between the washing module and the top of the cell cleaning tool. This replaces the tube you removed in the previous step.
5	Remove the tube between the washing module and the side of the Ccell cleaning tool. This is the tube that extrudes horizontally from the cell cleaning tool.
6	Install the replacement tube between the washing module and the side of the cell cleaning tool. This replaces the tube you removed in the previous step.

### Syringe Cleaning Vial

Step	Action
1	Locate the tube that was set aside above.
2	Remove the tubing from the syringe cleaning vial barb and washing module.
3	Attach a replacement tube to the syringe cleaning vial barb and washing module.

### Waste bottle

Step	Action
1	Locate one of the two pieces of tubing with the hard plastic end. Select the one with the desired length.
2	Remove the old tube from the waste bottle and washing module.
3	Attach the replacement tubing to the waste bottle and washing module.

## Replacing bottle filters

Use this procedure if the volume delivery has decreased due to a clogged filter. As a best practice, you should follow this procedure for one bottle at a time.

Step	Action
1	Disconnect the tubing from the top of the bottle.
2	Unscrew the bottle cap.
3	Remove the filter at the end of the tubing by gently pulling the filter from the tube.
4	Install a new filter (MCH02167) at the end of the tubing.
5	Replace the bottle cap.
6	Reconnect the tubing to the bottle cap.

## Replacing cleaning module O-ring

Use this procedure if the o-ring appears worn or the tool fits loosely in the cell port. The accessory kit contains a bag of replacement o-rings (ORG-0005V-010).

Step	Action
1	Locate the cell cleaning module o-ring.
2	Remove the o-ring by using a pair of tweezers (not provided).

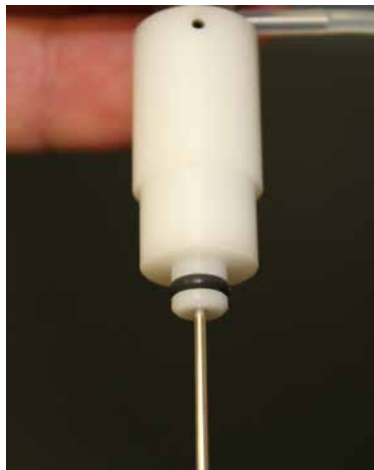

3	Install the new o-ring.
---	-------------------------

## Replacing the vacuum tube

Use this procedure to remove contamination from the washing module vacuum tube.

Step	Action
1	Remove the vacuum tube from the washing module by turning it counter-clockwise.



2	Install the vacuum tube (Part # ASY020555) into the washing module by turning it clockwise until tight.
3	Run the Cell Buffer Rinse (short) procedure to verify proper operation.

## 7.4 Replacing the syringe plunger tip

The plunger tip forms a seal with the syringe glass. Consequently, it spins along with the syringe glass while the metal plunger itself remains stationary. As the plunger drives titrant out of the syringe glass, wear on the plunger tip can occur. Too much wear can manifest itself as poor data. If left unreplaced, the plunger can drive itself through the tip. Best practice is to replace the tip at the first sign of wear (PTFE shavings along plunger shaft, above tip) or about every 300 experiments. Practice this a few times so as to become comfortable with the routine.

To replace the syringe plunger tip, follow the steps described below:

- | Step | Action   |
|------|--|
| 1    | Place the pipette assembly in the (empty) titrant load location. |
| 2    | Loosen and remove the securing nut from bottom of the pipette.   |



- 3 In the MicroCal iTC<sub>200</sub> software, click on the **Instrument Controls** tab and click **1. Remove Old Tip** in the **Maintenance** section.

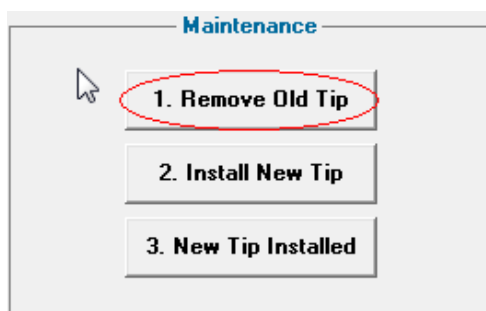

## 7 Maintenance

### 7.4 Replacing the syringe plunger tip

Step	Action
------	--------

- |   |   |
|---|---|
| 4 | The software prompts to remove the old tip. |
|---|---|



- |   |  |
|---|--|
| 5 | Click <b>OK</b> .<br>Without the nut, the syringe moves down with the plunger. |
|---|--|



Step	Action
6	Grab the syringe bore firmly and pull straight down to remove the syringe from the pipette. The soft-grip tweezers can be used to help grip the syringe without damaging it. Set the syringe aside.



7	The tip of the tip puller uses a traction design that grabs the plunger tip and allows movement only in one direction.
---	--



## 7 Maintenance

### 7.4 Replacing the syringe plunger tip

Step	Action
------	--------

- |   |   |
|---|---|
| 8 | Insert the tip puller into the pipette until the tip of the puller grabs the plunger tip. Then gently extract the tip puller (along with the pipette tip) from the pipette. |
|---|---|

**Note:**

*Make sure nothing falls into the cell.*



- |   |   |
|---|---|
| 9 | In the MicroCal iTC <sub>200</sub> software, click on the <b>Instrument Controls</b> tab and click <b>2. Install New Tip</b> in the <b>Maintenance</b> section. |
|---|---|

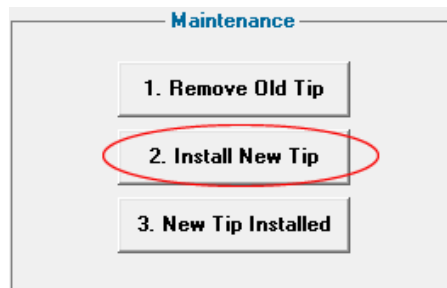

The plunger moves downward and displays the following message:





Step	Action
10	Click <b>OK</b> .
11	Insert a new plunger tip inside the tip pusher tool.
12	The tip pusher tool has a hole on one side. Insert the plunger tip inside that hole with the plunger tip hole facing outward.



## 7 Maintenance

### 7.4 Replacing the syringe plunger tip

Step	Action
13	Insert the tip pusher and new tip into the pipette and press the tip into place. Once the tip slips over the barbed plunger, remove all pressure.

**Note:**

*Do not push too hard. Resistance should be felt initially.*



Step	Action
14	In the MicroCal iTC <sub>200</sub> software, click on the <b>Instrument Controls</b> tab and click <b>3. New Tip Installed</b> in the <b>Maintenance</b> section.

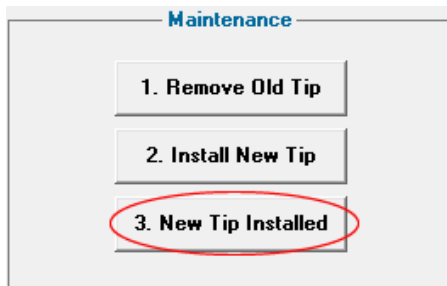

See Section 7.5 *Replacing and cleaning the titration syringe*, on page 268 to reinstall the syringe.

## 7.5 Replacing and cleaning the titration syringe

### Introduction

The syringe must be removed, cleaned and carefully inspected as a part of preventive maintenance. To inspect the upper section of the syringe, it must be removed from the pipette.

Step	Action
------	--------

- |   |   |
|---|---|
| 1 | Check the upper (glass) section of the syringe extra carefully. |
| 2 | Replace the syringe if it shows any sign of damage.             |

A broken syringe will not operate in the wash/load station properly, will likely result in poor experimental results, and could contaminate the cell with broken glass. A dirty syringe is not nearly as common as a dirty cell but can also result in poor data.

Detergent cleaning of the syringe between runs is recommended if performing reverse titrations (protein is loaded into the syringe). If poor data persists after extensive cell cleaning, remove the syringe for cleaning.



#### WARNING

The syringe may be contaminated with hazardous residual compounds. Consult your completed Health and Safety Declarations Form to determine if any biologically or chemically hazardous substances have been used in the instrument. Use the appropriate personal protective equipment (PPE) as specified in the MSDS for those substances.

**Note:** *If the inspection of the syringe shows a break at or near the fill port, inspect the fill port adaptor carefully.*

### Removing the titration syringe

To remove the titration syringe, follow the steps described below:

Step	Action
------	--------

- |   |  |
|---|--|
| 1 | Place the pipette assembly in the (empty) titrant load location. |
|---|--|

Step	Action
2	Loosen and remove the securing nut from bottom of the pipette.



## 7 Maintenance

### 7.5 Replacing and cleaning the titration syringe

- | Step | Action   |
|------|--|
| 3    | In the MicroCal iTC <sub>200</sub> software, click on the <b>Instrument Controls</b> tab and click <b>1. Remove Old Tip</b> in the <b>Maintenance</b> section. |

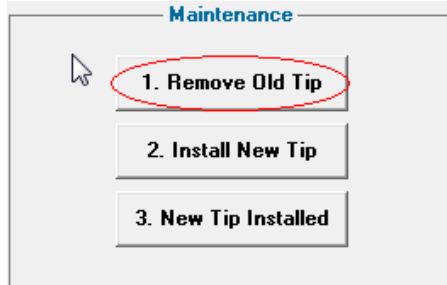

Without the nut, the syringe moves down with the plunger.



Step	Action
------	--------

- 4 Grab the syringe bore firmly and pull straight down to remove the syringe from the pipette. The soft-grip tweezers can be used to help grip the syringe without damaging it. Set the syringe aside.



- 5 Once the syringe has been removed from the pipette, inspect it carefully for cracks, chips and breaks.  
If the syringe shows any signs of damage, it must be replaced.

**Note:**

*If the inspection of the syringe shows a discernible crack or break at or near the fill port adaptor (FPA) input, inspect the fill port adaptor carefully.*

If the syringe will continue to be used, clean the top section carefully with the syringe brush.

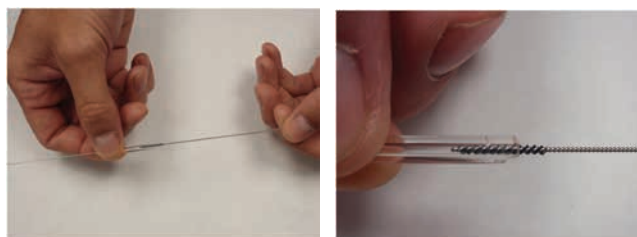

- 6 Slide the syringe brush in gently as far as it will go and then withdraw it. If the syringe is particularly dirty, use Contrad 70 detergent on the brush and repeat as many times as necessary until the syringe is completely clean.

## 7 Maintenance

### 7.5 Replacing and cleaning the titration syringe

Step	Action
------	--------

- |   |   |
|---|---|
| 7 | Once the top section is clean, run the small piece of wire through the channel in the syringe while watching for exiting material at the bottom of the syringe. It may take a few attempts to thread the wire into the channel. |
|---|---|

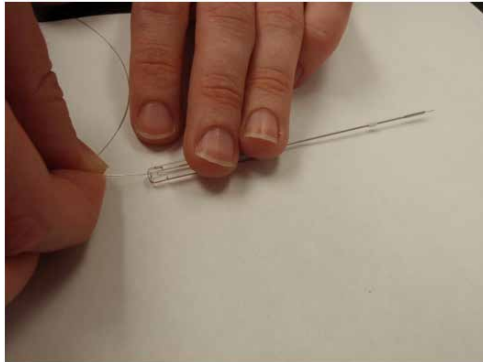

- |   |   |
|---|---|
| 8 | Rinse the syringe well. Replace the syringe if any material remains in the syringe that cannot be removed by this method.   |
| 9 | Once the syringe is clean, carefully inspect the topmost section for evidence of cracks. Cracks tend to originate at the fill port, which is the horizontal hole where the fill port plunger slides into the syringe. Inspect that area carefully while slowly rotating the syringe to look for the cracks. |

If inspection shows that the top section of the syringe has cracks or other damage, or if you are unable to pass the wire through the channel in the syringe, the syringe must be replaced.

Always examine the fill port adaptor closely following the identification of a damaged syringe.

**Note:** *A clogged or partially clogged syringe will result in filling problems that will show up as bad data when tests are conducted.*

## Installing the titration syringe

The top portion of the syringe is keyed to slide into the pipette in only one way. The groove in the glass is keyed to slide into the small stop pin in the syringe holder.

**Tip:** *Syringes designed for MicroCal Auto-iTC<sub>200</sub> may be used in the MicroCal iTC<sub>200</sub>. The alignment pin clearance is absent in the MicroCal iTC<sub>200</sub> syringes, so the opposite is not true.*





To insert a titration syringe, follow the steps described below:

- | Step | Action  |
|------|---|
| 1    | In the MicroCal iTC <sub>200</sub> software, click on the <b>Instrument Controls</b> tab and click <b>3. New Tip Installed</b> in the <b>Maintenance</b> section. |

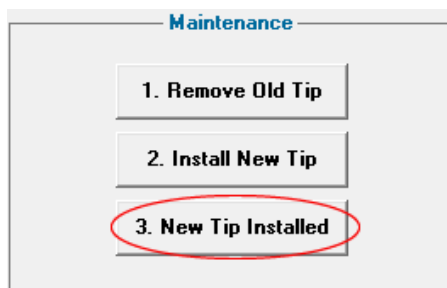

*Result:* The plunger is moved to the topmost position.

## 7 Maintenance

### 7.5 Replacing and cleaning the titration syringe

Step	Action
2	Rotate the opening in the pipette forward and gently push the new syringe up into the pipette. Use the index finger of one hand to keep some pressure on the back side of the pipette to keep it from rotating. Keep the syringe's fill port facing front, aligned to the opening in the pipette, while sliding the syringe up and into the pipette.



Step	Action
3	The syringe usually comes to a stop with about 4 mm of syringe glass exposed below the metal. (If it seats directly then there will be about 2 mm of glass exposed and the pipette and syringe can no longer be moved independently.)



## 7 Maintenance

### 7.5 Replacing and cleaning the titration syringe

Step	Action
4	Hold the pipette with an index finger while rotating the syringe with the other hand. When the fill port in the syringe aligns with the opening in the pipette, slide the syringe up approximately another 2 mm.



**Note:**

*When the syringe is properly seated, the syringe and the syringe holder in the pipette are locked together. The syringe is not properly seated if the syringe can spin without spinning the syringe holder.*

Step	Action
5	Replace and tighten the bottom nut. Be careful not to bend or otherwise damage the paddle when reinstalling the bottom nut. Note that the tightening of the bottom nut onto the syringe affects the ultimate height of the syringe in the pipette. Over or under tightening the nut can cause a vertical misalignment of the connection between the syringe and the fill port plunger. The bottom nut should be snug but easily removed.



# 8 Troubleshooting

## Introduction

This section contains tips and information for troubleshooting MicroCal iTC<sub>200</sub>.

---

## In this chapter

This chapter contains the following sections:

Section	See page
8.1 Peaks too large	279
8.2 Broad peaks	281
8.3 Downward stepping baseline	283
8.4 Upward stepping baseline	284
8.5 Reversed/oscillating peaks	285
8.6 Baseline spikes	286
8.7 Low baseline	288
8.8 Abnormal peaks	290
8.9 Unexpected thermodynamic results	292
8.10 Washing Module	294

---

## 8.1 Peaks too large

### Introduction

Baselines should always be within  $1 \mu\text{cal/s}$  of the user-specified reference power. A normal baseline noise is visible between the tiny water into water injection peaks, if the titration syringe and cannulas are properly cleaned and completely dry so that there is no residual methanol.

The figure below came from an instrument with a broken fill port adaptor (FPA). If methanol is suspected of contaminating experiments, be sure to check the condition of the FPA.

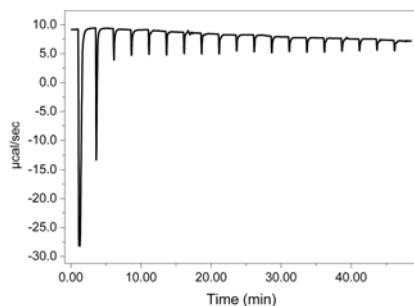

The figure below depicts a binding event before and after dialysis.

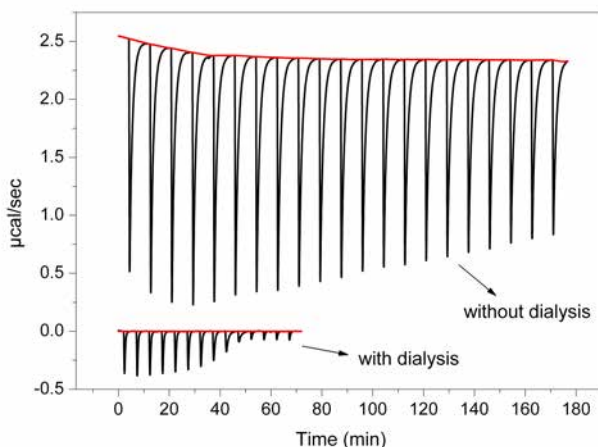

## Problem causes

There are several causes of peaks being too large.

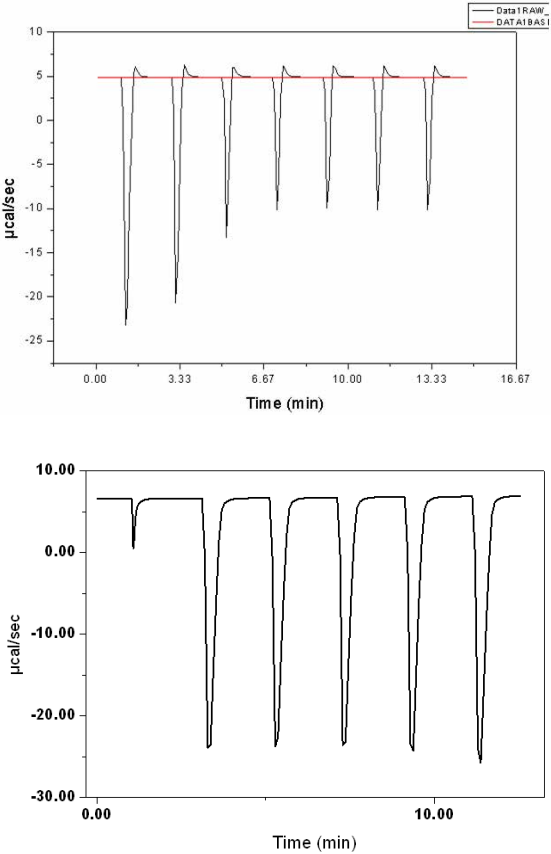
Cause	Corrective action
<p>A buffer mismatch between the titrant and cell material.</p>	<p>Revisit sample preparation in <i>Section 5.1 Preparing the samples</i>, on page 88.</p>
<p>Methanol: All samples have consistently large peaks.</p>  <p>The figure contains two chromatograms. The top graph plots signal in <math>\mu\text{cal/sec}</math> against Time (min) from 0.00 to 16.67. It shows a red horizontal line at approximately 4.5 <math>\mu\text{cal/sec}</math> and a black line with several sharp negative peaks reaching down to -25 <math>\mu\text{cal/sec}</math>. The bottom graph plots signal in <math>\mu\text{cal/sec}</math> against Time (min) from 0.00 to 10.00, showing a black line with sharp negative peaks reaching down to -30.00 <math>\mu\text{cal/sec}</math>.</p>	<p>The peaks will exhibit extreme heat signatures in the presence of any residual methanol. The “bounce” after each injection is typical when the signal goes below 0.</p> <ul style="list-style-type: none"> <li>• Check wash module fittings.</li> <li>• Make sure that the syringe is being adequately dried.</li> </ul>



## 8.2 Broad peaks

### Introduction

To measure the heat accurately, the spacing between injections should be sufficient to allow the signal to return to baseline.

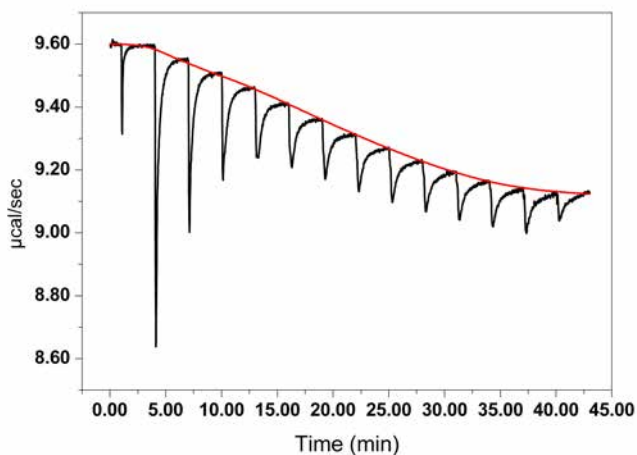

### Problem causes

Cause	Corrective action
Injection spacing is too short	Increase the injection spacing in the ITC Method or change the injection spacing "on-the-fly" (see <i>Section 4.2.5 Advanced Experimental Design tab, on page 65</i> ).
Feedback mode is set to an unexpected value. This directly affects the response time of the instrument. Low feedback (or none) requires larger injection spacing than the high feedback setting.	Check the feedback setting and adjust it, or the injection spacing, accordingly.

## 8 Troubleshooting

### 8.2 Broad peaks

Cause	Corrective action
<p>The kinetics of the system can also affect the time required to return to baseline. If a given system routinely takes a long time, and the injection spacing is set to just return to baseline, on rare occasions the baseline fitting algorithm will not perform well.</p>	<p>Increase injection spacing.</p>

## 8.3 Downward stepping baseline

### Introduction

The baseline might start in the normal range, within 1  $\mu\text{cal/s}$  of the reference power, but after each injection, the baseline steps down. The heat capacitance of the sample cell also decreases with each injection.

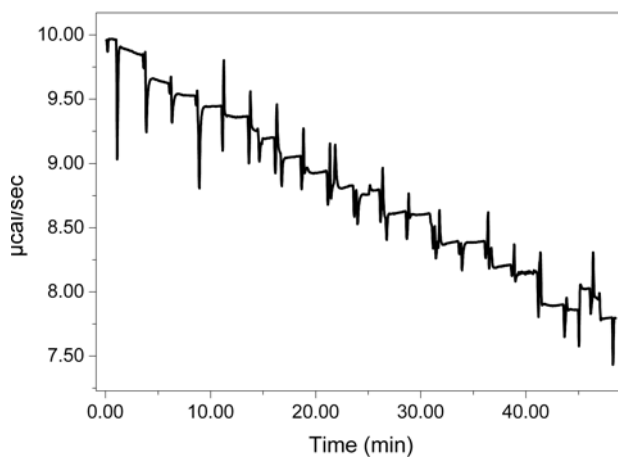

### Problem causes

There are several causes of a downward stepping baseline.

Cause	Corrective action
The titration syringe is empty or underfilled.	The syringe injects air into the cell, which shifts the heat capacity of the sample cell and offsets the baseline.
The small fill port adaptor tip that fits into the fill port in the syringe is damaged.	Please contact Malvern Instruments.

## 8.4 Upward stepping baseline

### Introduction

The upward steps result from the sample cell getting more full with each injection. The heat capacitance of the sample cell also increases with each injection.

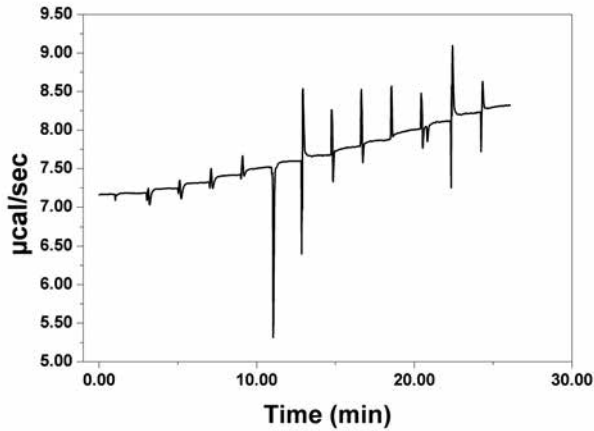

### Problem causes

The causes of an upward stepping baseline are described below.

Cause	Corrective action
The cell is dirty.	Clean the cell.
The sample cell is underfilled.	Make sure the cell was loaded with enough sample (minimum 280 µl).

## 8.5 Reversed/oscillating peaks

### Introduction

Reversed peaks is a rather strange-looking condition in which the baseline starts flat and the peaks initially look normal, but start to shrink quickly midway through the run and then drift in the opposite direction. The baseline may start low, but begins to drift slightly as the peaks reverse their direction.

### Problem causes

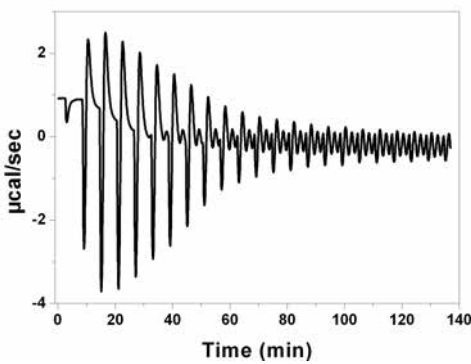
Cause	Corrective action
<p>Reversed/oscillating</p> 	<p>This oscillatory behavior is due to the differential power dropping below 0. Set the reference power higher.</p>

## 8.6 Baseline spikes

### Introduction

If there are spikes in the baseline, the automated baseline fitting may have difficulties.

Two types of bubble spikes are observed:

- Sharp isolated spikes typically occur when the samples are held at a temperature about 15°C lower than the experimental temperature. Greater gas solubility at lower temperatures can cause bubbles to come out of solution during experiments.
  - Prolonged noise spikes are more likely to occur when the experimental temperature is about 15°C above the storage temperature.
- 

### Sharp spikes

The graph below displays sharp isolated baseline spikes.

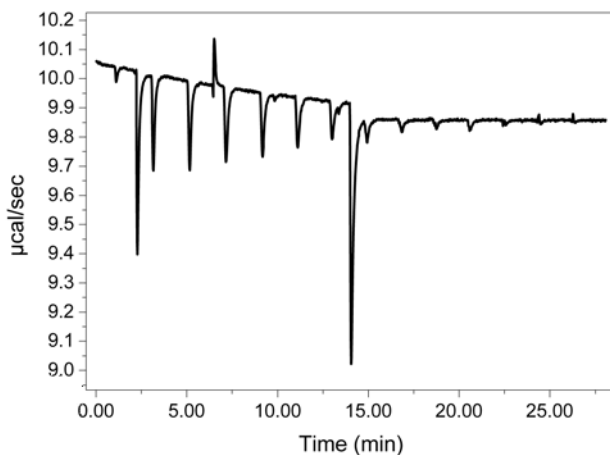

## Prolonged noise spikes

The graph below exhibits prolonged noise baseline spikes (in black), as well as a sharp, isolated spike (in green).

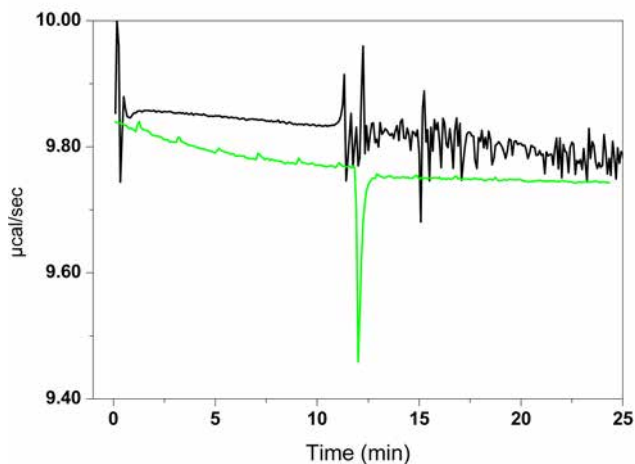

## Problem causes

Cause	Corrective action
Air bubbles are trapped in the cell.	<ul style="list-style-type: none"> <li>• Degas the sample solution properly (see <i>Section 5.1 Preparing the samples, on page 88</i>).</li> <li>• Spikes are convoluted with an injection. Discard that data point and manually fit using Origin.</li> <li>• Spikes are confined to an injection's baseline. Save the data point by removing the spike in Origin.</li> </ul>

## 8.7 Low baseline

### Introduction

If the baseline settles at more than  $1 \mu\text{cal/s}$  below the user-specified reference power, the results may be less than optimal. For example, the reference power was set to 10 in the example illustrated below. The data look fine, aside from the displaced baseline position. However, the stoichiometric result may be slightly affected.

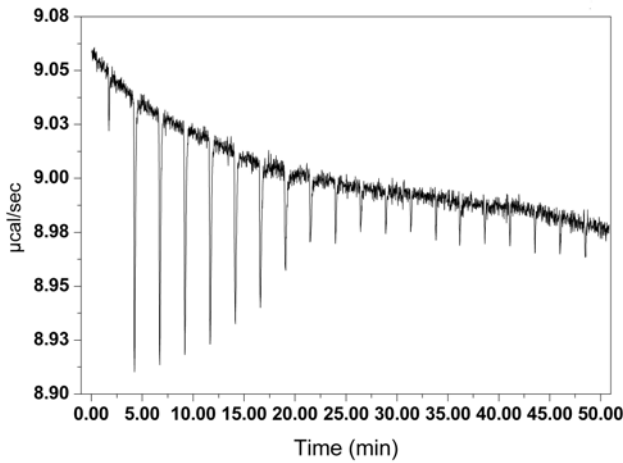

### Problem causes

There are several causes of a low baseline, but they all center around an underfilled cell.

Cause	Corrective action
Dirty cell caused a poor load.	Clean the cell.
Air bubbles are trapped in the cell.	Degas the sample solution properly.
The sample cell is underfilled.	Make sure the cell was loaded with enough sample (minimum $280 \mu\text{l}$ ).



Cause	Corrective action
<p><b>Note:</b> <i>A baseline position larger than the reference power might be due to an underfilled (or evaporated) reference cell.</i></p>	<p>Fill the reference cell (see <i>Section 7.2 Refilling the reference cell, on page 255</i>)</p>

## 8.8 Abnormal peaks

### Introduction

A few examples of abnormal peaks are illustrated below.

---

### Example 1

The repeatable trend displayed below implies that the sample cell needs cleaning.

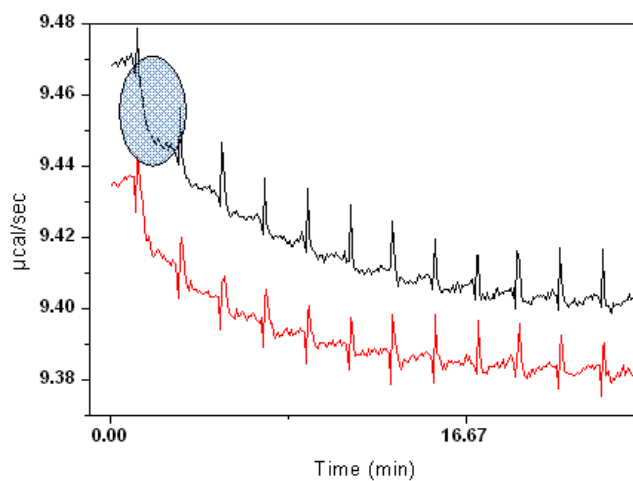

## Example 2

In the example illustrated below, there was not enough time left between injections. Increase the spacing between injection and/or check the feedback settings. See *Section 8.2 Broad peaks*, on page 281 for a similar discussion.

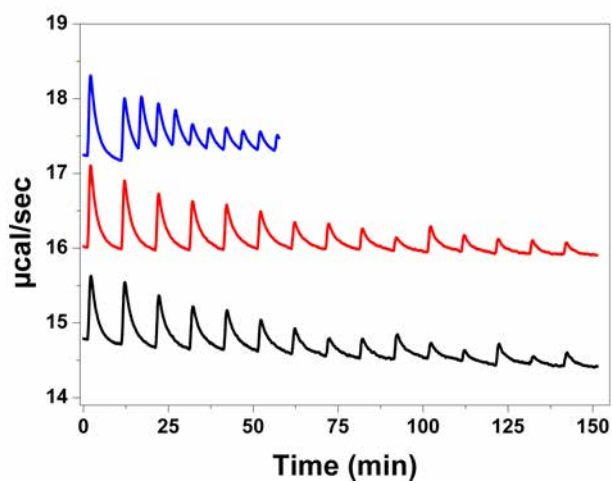

## 8.9 Unexpected thermodynamic results

### Introduction

Often results do not yield a "textbook" sigmoidal binding isotherm. This may be a result of the system itself, or sample preparation, or both. Several scenarios are described below to help diagnose the problem.

### Problem causes

There are several causes of unexpected thermodynamic results. Keep the following scenarios in mind when troubleshooting results:

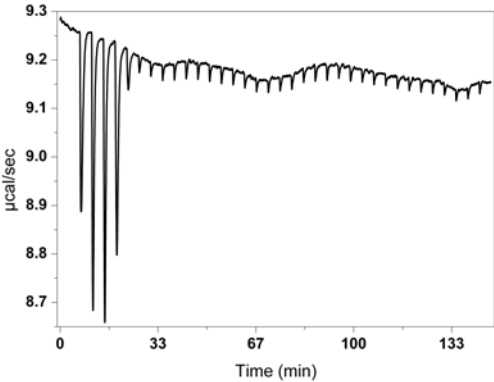
Observed result	Corrective action
Stoichiometry (n) varies with enthalpy ( $\Delta H$ ).	Check that the syringe concentration is correct.
Stoichiometry (n) varies alone.	Check that the cell concentration is correct.
Early saturation.	<ul style="list-style-type: none"> <li>• Increase protein concentration or decrease ligand concentration.</li> <li>• Examine sample preparation (see <i>Section 5.1 Preparing the samples, on page 88</i>).</li> </ul> 
Experimental heats are same as control heats.	Change experimental temperature by at least 10°C and/or increase sample concentration.

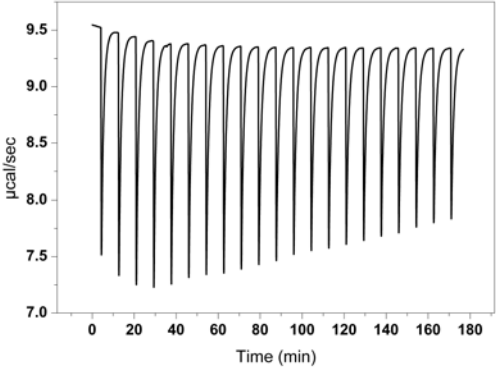
Observed result	Corrective action
No saturation.	<p>Weaker-than-expected binding or buffer mismatch.</p>  <p>The figure is a plot of heat flow in <math>\mu\text{cal/sec}</math> versus time in minutes. The y-axis ranges from 7.0 to 9.5 with major ticks every 0.5 units. The x-axis ranges from 0 to 180 with major ticks every 20 units. The plot shows a series of approximately 18 injection peaks. Each peak is a sharp downward spike from a baseline that is slowly increasing over time. The peaks do not reach a common plateau, indicating that the binding sites are not saturating.</p>

## 8.10 Washing Module

Washing module troubleshooting is described below.

### No flow during washing

Cause	Corrective action
Tubing connection	Make sure that all connections are tight
Clogged pump	Call for Service
Clogged bottle filter	see <i>Replacing bottle filters, on page 258</i>
Vacuum tube not tight	Tighten the vacuum tubing

### Syringe fill failure

Cause	Corrective action
Tubing connection	Make sure that all connections are tight
Clogged syringe paddle	See <i>Section 7.5 Replacing and cleaning the titration syringe, on page 268</i> for instructions on how to clean the titration syringe.
Damaged Filling Port Adapter	Check that the tip is not deformed
Broken glass	<ol style="list-style-type: none"><li>1 Make sure that the syringe glass near the fill port has not been damaged</li><li>2 Call for Service</li></ol>

### Syringe not dry

Cause	Corrective action
Methanol bottle empty	Fill the methanol bottle

### Washing module not recognized by MicroCal iTC<sub>200</sub> during hardware detection

Cause	Corrective action
USB connection problem	Verify that all USB connections are tight at the hub and controller PC

### Washing module pump does not run

Cause	Corrective action
Power connection problem	Verify that the coaxial power connector is securely connected to the rear of the washing module

# 9 Reference information

## Introduction

This chapter provides reference information that may be useful when installing, operating, maintaining and troubleshooting the MicroCal iTC<sub>200</sub> system. It also contains ordering information.

---

## In this chapter

This chapter contains the following sections:

Section	See page
9.1 How to get help	297
9.2 Networking	299
9.3 MicroCal iTC <sub>200</sub> ITC methods	306
9.4 MicroCal iTC <sub>200</sub> specifications	307
9.5 Reagents	309

---



## 9.1 How to get help

### Contact information

Please contact Malvern Instruments for any instrument or data analysis questions or issues you may have.

For contact information for your local office, please visit: [www.malvern.com/contact](http://www.malvern.com/contact) or for MicroCal-specific information, please visit: [www.malvern.com/microcal](http://www.malvern.com/microcal)

### Include data file

When e-mailing for technical assistance, if possible, please attach a recent data file(s) (\*.itc raw ITC data file) that demonstrates the problem. Also, please include all details that may be relevant to the problem. Where the problem or question relates to post run data analysis, it is best to attach the raw data file (\*.itc).

### Problem categories

There are two general categories of troubleshooting for MicroCal iTC<sub>200</sub> and its operation.

Problem category	Description
1 (severe)	The system is not working at all. Problems that prevent the operation of the instrument require immediate consultation with a Malvern Instruments technician. Customers should not attempt to repair the hardware or software unless instructed to do so by a Malvern Instruments service representative.
2 (moderate)	The MicroCal iTC <sub>200</sub> instrument is functioning, but is not operating within its normal performance specifications. Large baseline drifting, non-repeatable control peaks (water/water) and/or an increase in short term noise level are examples of performance problems. These problems may be corrected by the operator in most cases. For these types of performance issues, Malvern Instruments recommends that customers perform a few diagnostic steps prior to requesting service.

### Diagnosing the problem

Perform the following minimum diagnostic steps prior to requesting service:

## 9 Reference information

### 9.1 How to get help

Step	Action
1	Run a thorough cleaning routine.
2	Set up a run of degassed, distilled water being injected into degassed, distilled water.
3	Start the run. If possible, observe the cleaning and loading routines.

If, after completion of the steps listed above, the MicroCal iTC<sub>200</sub> performance is not corrected, please contact the service department for help. The water runs should be provided to the MicroCal service technician for evaluation. Following the evaluation, a representative from the service department will contact you with comments and recommendations.

## 9.2 Networking

**Note:** *If the instrument must be connected to a network, each subcomponent of this iTC<sub>200</sub> software installation must be performed with full ADMINISTRATIVE MicroCal privileges.*

Networking requirements are operating system specific.

### For Windows XP operating systems:

- If the instrument must be connected to a network, each subcomponent of the iTC<sub>200</sub> software installation must be performed with full administrative privileges.
- Once the system is operational, if users without administrative privileges will be operating the system, then the access rights of those users must be modified by the administrator in order to assure a proper operating environment for those users.

### For Windows 7 operating systems:

Verify that the Windows 7-based configuration settings described below have been completed:

- *Section 3.3.1 Modify the Origin 7 configuration for Windows 7, on page 50*
- *Section 3.3.2 Modify the MicroCal iTC<sub>200</sub> software configuration for Windows 7, on page 52*
- *Section 3.3.3 Modify the user account control settings for Windows 7, on page 54*

Once the system is operational, if users without administrative privileges will be operating the system, then the access rights of those users must be modified by the administrator in order to assure a proper operating environment for those users.

## Installing a Windows XP-based system onto a network

Before beginning the installation, make sure you are logged into the PC with full administrative privileges.

If the software will be run by users without administrative privileges, do the following to assure proper operating environment for MicroCal iTC<sub>200</sub> and Origin 7.0 software:

On a system using Windows XP, do the following:

Step	Action
1	Make sure you are logged onto the PC with administrative privileges.
	<p><b>Note:</b></p> <p><i>Please consult the local IT department for instructions regarding the changing of local security settings.</i></p>
2	Go to <b>My Computer</b> and navigate to C:\ITC200.

Step	Action
3	Right-click the folder, C:\ITC200 and select <b>Properties</b> .
4	Click the <b>Security</b> tab.  <b>Note:</b> <i>In Windows XP Home Edition and Windows XP Professional, if working in a workgroup, the Security tab is hidden by default. This behavior occurs because in Windows XP Home Edition and Windows XP Professional, guests are forced to log on to a workgroup. To resolve this, see the Microsoft knowledgebase article #290403: <a href="http://support.microsoft.com/kb/290403/">http://support.microsoft.com/kb/290403/</a>. Article 290403 is also on the installation CD in the <b>Documents</b> folder. Important Resolving this problem requires you to modify the registry. However, serious problems might occur if you modify the registry incorrectly. For added protection, back up the registry before you modify it. Then, you can restore the registry if a problem occurs. For more information about how to back up and restore the registry, see the Microsoft knowledge base article # 322756: <a href="http://support.microsoft.com/kb/322756/">http://support.microsoft.com/kb/322756/</a></i>
5	Specify <b>Full Control</b> for the user or the group, <b>Users</b> .

**Step**      **Action**

- 6      Navigate to `C:\Program Files\OriginLab\Origin7\` and repeat steps 3–5.

Security properties for ITC<sub>200</sub> software:

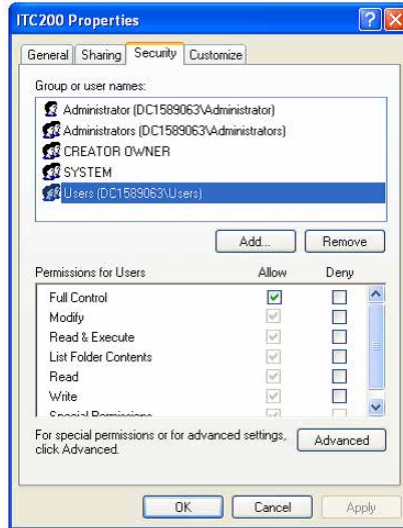

Security properties for Origin software:

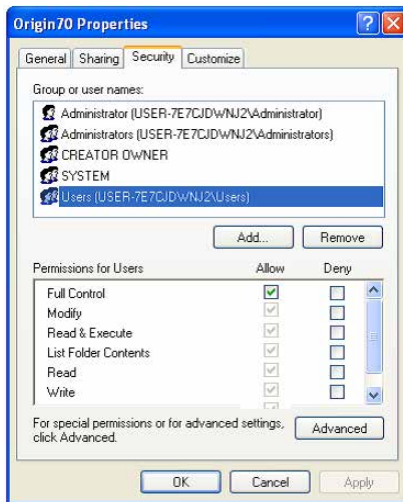

In the images above, each user is a member of the Users group by default. Simply increase the permission level of the group by selecting **Full Control**.

Step	Action
------	--------

7	If InitDT service is installed, you must uninstall it.
---	--

InitDT service is incompatible with users without administrative privileges. Failure to uninstall InitDT service in this case will result in instrument malfunction.

**Note:**

*InitDT Service should not be installed on models 02.10.310 or higher or on an older system that has a newer version of the DT9836 board, firmware, and driver installed. (refer to service records if necessary.)*

To uninstall InitDT service, go to the **Control Panel>Add or Remove Programs**, navigate to InitDTSetup, and click **Remove**.

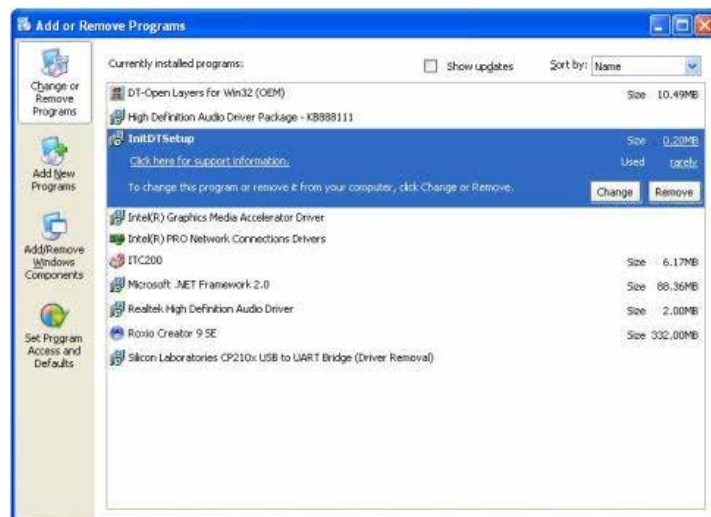

## Installing a Windows 7-based system onto a network

Before beginning the installation, make sure you are logged into the PC with full administrative privileges.

If the software will be run by users without administrative privileges, do the following to assure proper operating environment for MicroCal iTC<sub>200</sub> and Origin 7.0 software:

On a system using Windows 7, do the following:

Step	Action
1	Make sure you are logged onto the PC with administrative privileges.  <b>Note:</b> <i>Please consult the local IT department for instructions regarding the changing of local security settings.</i>
2	Go to <b>My Computer</b> and navigate to C:\ProgramData\MicroCal.
3	Right-click the folder, C:\ProgramData\MicroCal and select <b>Properties</b> .
4	Click the <b>Security</b> tab.
5	Specify <b>Full Control</b> for the user or the group, <b>Users</b> .

**Step**    **Action**

6            Security properties for iTC<sub>200</sub> software:

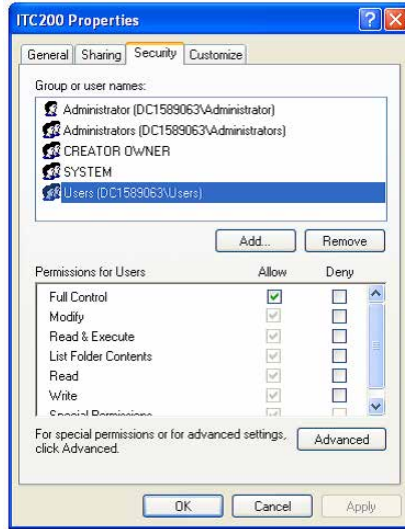

Full permissions for C:\ProgramData\MicroCal for Windows 7-based networking:

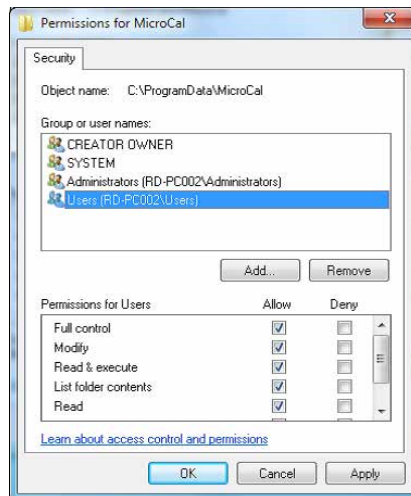

In the images above, each user is a member of the Users group by default. Simply increase the permission level of the group by selecting **Full Control**.



**Step**      **Action**

- 7      If InitDT service is installed, you must uninstall it.  
InitDT service is incompatible with users without administrative privileges. Failure to uninstall InitDT service in this case will result in instrument malfunction.

**Note:**

*InitDT Service should not be installed on models 02.10.310 or higher or on an older system that has a newer version of the DT9836 board, firmware, and driver installed. (refer to service records if necessary.)*

To uninstall InitDT service, go to the **Control Panel>Add or Remove Programs**, navigate to InitDTSetup, and click **Remove**.

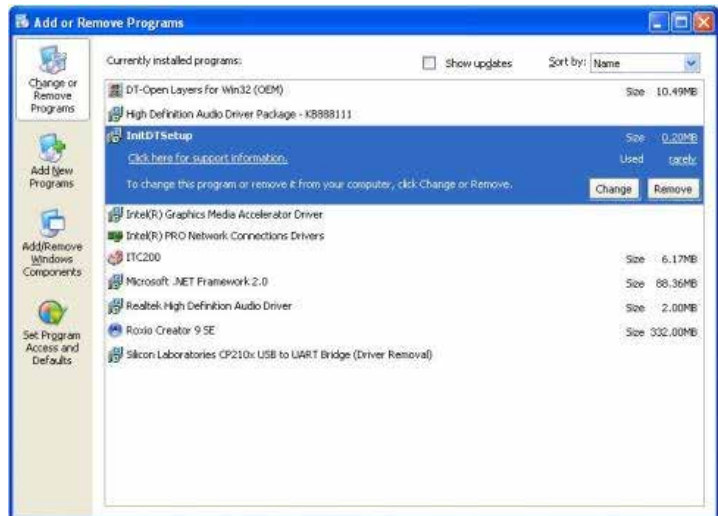

## 9.3 MicroCal iTC<sub>200</sub> ITC methods

The ITC method files have the extension (.inj) and are found in the location (C:\ITC200\Setup).

The standard ITC methods provided with the controller are:

- ***lastrun1.inj*** is a special file created and used by the software, which contains the parameters of the last run.
- ***EDTA.inj*** contains the parameters for the CaCl<sub>2</sub>/EDTA kit provided by Malvern Instruments, and may be used as the basis for sample titration setup files.
- ***NoiseTest.inj*** is a 0 injection run used for standard testing of instrument noise.
- ***WATER.inj*** is a 19 injection run, intended for water-into-water or buffer-into-buffer titrations.

## 9.4 MicroCal iTC<sub>200</sub> specifications

### Performance specifications

Property	Value
Operating Temperature Range	2°C to 80°C
Response Time	10 seconds
Cell Design	200 µl, coin-shaped
Titration Syringe	40 µl
Maximum Usable Volume	38 µl
Stirring Rate	500 to 1500 rpm

### Physical specifications

Property	Value
Cell Material	Hastelloy Alloy C-276
Weight (fully assembled):	9.4 kg
Dimensions: Calorimeter (W x H x D)	21 × 33.7 × 34.9 cm

### Electrical specifications

Electrical specifications are for the calorimeter and Autosampler only. Autosampler specifications, where different, are enclosed in parentheses.

Part	Function
Electrical Ratings:	
Voltage	100 to 240 V grounded
Frequency	50 / 60 Hz
Power	70 W (300 W)
Fuses (2)	4.0 A, 5.0 A, 250 V, Time delay (Fast acting)
Output	Secondary/Data connection only

## 9 Reference information

### 9.4 MicroCal iTC<sub>200</sub> specifications

Part	Function
Protective Earth Terminals	Internal/external marked (Internal marked)
Mode of Operation	Continuous
Classification	Class I

## Site requirements

Part	Function
Benchspace	<ul style="list-style-type: none"><li>• ≥3 ft (92 cm) of lab bench,</li><li>• ≥15 in. (40 cm) in depth,</li><li>• no obstructions for at least 32 in. (80 cm) above bench,</li><li>• rated for at least 250 lbs (115 kg).</li></ul> <p>These include the clearances. Service functions will require an additional 12 in. (31 cm) overhead clearance.</p>
Clearance	<ul style="list-style-type: none"><li>• ≥6 in. (15 cm) behind the Calorimeter,</li><li>• ≥15 in. (40 cm) in front.</li></ul>

## Atmospheric specifications

Part	Function
Operating: Temperature	10°C to 28°C
Humidity	0% to 70% RH, non-condensing
Atmospheric Pressure	700 to 1060 mbar (700 to 1060 hPa)
Storage (no liquid in cells): Temperature	-25°C to 60°C (no liquid in cells)
Humidity	10% to 90%, non-condensing
Atmospheric Pressure	500 to 1060 mbar (500 to 1060 hPa)

## 9.5 Reagents

### Reagent requirements

- Distilled water
- $\geq 99\%$  pure methanol ("HPLC Grade" is recommended)



#### WARNING

Methanol is highly volatile and can be hazardous to humans.

- Storage containers should be kept tightly closed.
- Methanol should always be transferred in a well-ventilated area with no ignition sources. The operator should have protective clothing and gloves.
- Methanol can be absorbed through the skin. Do not allow methanol to be swallowed or to come in contact with skin or eyes. If accidental exposure occurs, flush the affected area with water. If methanol is swallowed, or there is significant skin or eye exposure, seek medical help.

- Detergent: 20% Contrad 70 from Decon Laboratories, Inc., King of Prussia, PA, USA (or 14% Decon 90 from Decon Laboratories Limited, Hove, East Sussex, UK) is the recommended detergent. Contrad 70 and Decon 90 contain dodecylbenzensulfonic acid, potassium hydroxide, sodium citrate and sodium laurel ether sulfate. It is biodegradable and can be rinsed off easily.

# Appendix A Equations used for fitting ITC data

## General considerations

**Note:** *It will be assumed throughout that the macromolecule  $M$  is in the cell at an initial bulk concentration (moles/l) before the first injection, and the ligand  $X$  to be injected is initially at zero concentration in the cell.*

The working volume (grey) of the lollipop-shaped cell is  $V_o$ , the size of the  $i^{th}$  injection is  $\Delta V_i$  and the total liquid, which has been injected at any point during the experiment,  $\Delta V$ , is simply the sum of the individual  $\Delta V_i$  for all injections.

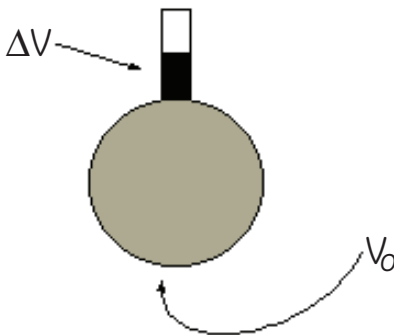

At the beginning of an experiment, both the cell and the long communication tube are filled with macromolecule solution, but it is only that contained within  $V_o$  that is sensed calorimetrically. Because of the total-fill nature of the cell, each injection acts to drive liquid out of the working volume and up into the inactive tube as shown by the darkened portion representing  $\Delta V$ . Thus, the concentration of macromolecule in  $V$  changes a small amount with each injection since the total number of moles of macromolecule initially in  $V$  (i.e., times  $V_o$ ) at the beginning of the experiment is later distributed in a larger volume,  $V_o + \Delta V$ . Since the average bulk concentration of macromolecule in  $\Delta V$  is the mean of the beginning concentration and the present concentration  $M_i$  in the active volume, conservation of mass requires that

**Equation 1:**

$$M_t^o V_o = M_t V_o + \frac{1}{2}(M_t + M_t^o)\Delta V \quad (1)$$

so that

**Equation 2:**

$$M_t = M_t^o \left[ \frac{1 - \frac{\Delta V}{2V_o}}{1 + \frac{\Delta V}{2V_o}} \right] \quad (2)$$

Using similar reasoning, it is easily shown that the actual bulk concentration of ligand in  $V_o$ ,  $X_t$ , is related to the hypothetical bulk concentration (assuming that all of the injected ligand remained in  $V_o$ ) as follows:

**Equation 3:**

$$X_t^o V_o = X_t V_o + \frac{1}{2}X_t \Delta V \quad (3)$$

**Equation 4:**

$$X_t = X_t^o \left[ \frac{1}{1 + \frac{\Delta V}{2V_o}} \right] \quad (4)$$

The above expressions for  $M_t$  and  $X_t$  are used by Origin to correct for displaced volume effects, which occur with each injection.

**Single set of identical sites**

In the following equations,

Parameter	Description
$K$	binding constant
$n$	number of sites
$V_o$	active cell volume
$M_t$	bulk concentration of macromolecule in $V_o$

## A Equations used for fitting ITC data

Parameter	Description
$[M]$	free concentration of macromolecule in $V_o$
$X_t$	bulk concentration of ligand
$[X]$	free concentration of ligand
$\Theta$	fraction of sites occupied by the ligand $X$

### Equation 5:

$$K = \frac{\Theta}{(1 - \Theta)[X]} \quad (5)$$

### Equation 6:

$$X_t = [X] + n\Theta M_t \quad (6)$$

Combining equations (5) and (6) above gives

### Equation 7:

$$\Theta^2 - \Theta \left[ 1 + \frac{X_t}{nM_t} + \frac{1}{nKM_t} + \frac{X_t}{nM_t} \right] = 0 \quad (7)$$

The total heat content  $Q$  of the solution contained in  $V_o$  (determined relative to zero for the unliganded species) at fractional saturation  $\Theta$  is

### Equation 8:

$$Q = n\Theta M_t \Delta H V_o \quad (8)$$

where  $\Delta H$  is the molar heat of ligand binding. Solving the quadratic equation (7) for  $\Theta$  and then substituting this into equation (8) gives

### Equation 9:

$$Q = \frac{nM_t \Delta H V_o}{2} \left[ 1 + \frac{X_t}{nM_t} + \frac{1}{nKM_t} - \sqrt{\left( 1 + \frac{X_t}{nM_t} + \frac{1}{nKM_t} \right)^2 - \frac{4X_t}{nM_t}} \right] \quad (9)$$



The value of  $Q$  above can be calculated (for any designated values of  $n$ ,  $K$ , and  $\Delta H$ ) at the end of the  $i^{\text{th}}$  injection and designated  $Q(i)$ . The parameter of interest for comparison with experiment, however, is the change in heat content from the completion of the  $i^{-1}$  injection to completion of the  $i$  injection. The expression for  $Q$  in equation (9) only applies to the liquid contained in volume  $V_o$ . Therefore, after completing an injection, it is obvious that a correction must be made for displaced volume (i.e.,  $\Delta V_i =$  injection volume) since some of the liquid in  $V_o$  after the  $i^{-1}$  injection will no longer be in  $V_o$  after the  $i^{\text{th}}$  injection, even though it will contribute to the heat effect (assuming the kinetics of reaction and mixing are fast) before it passes out of the working volume  $V_o$ . The liquid in the displaced volume contributes about 50% as much heat effect as an equivalent volume remaining in  $V_o$ . The correct expression for heat released,  $\Delta Q(i)$ , from the  $i^{\text{th}}$  injection is

**Equation 10:**

$$\Delta Q(i) = Q(i) + \frac{dV_i [Q(i) + Q(i-1)]}{2V_o} - Q(i-1) \quad (10)$$

The process of fitting experimental data then involves:

- 1 initial guesses (which most often can be made accurately enough by Origin) of  $n$ ,  $K$ , and  $\Delta H$
- 2 calculation of  $\Delta Q(i)$  for each injection and comparison of these values with the measured heat for the corresponding experimental injection
- 3 improvement in the initial values of  $n$ ,  $K$ , and  $\Delta H$  by standard Marquardt methods
- 4 iteration of the above procedure until no further significant improvement in fit occurs with continued iteration

## Two sets of independent sites

Using the same definition of symbols as above for set 1 and set 2, we have

**Equation 11:**

$$K_1 = \frac{\Theta_1}{(1 - \Theta_1)[X]} \quad (11)$$

$$K_2 = \frac{\Theta_2}{(1 - \Theta_2)[X]}$$

**Equation 12:**

$$X_t = [X] + M_t(n_1\Theta_1 + n_2\Theta_2) \quad (12)$$

Solving equation (11) for  $\Theta_1$  and  $\Theta_2$  and then substituting into equation (12) gives

**Equation 13:**

$$X_t = [X] + \frac{n_1 M_t [X] K_1}{1 + [X] K_1} + \frac{n_2 M_t [X] K_2}{1 + [X] K_2} \quad (13)$$

Clearing equation (13) of fractions and collecting like terms leads to a cubic equation of the form

**Equation 14:**

$$[X^3] + p[X^2] + q[X] + r = 0 \quad (14)$$

where,

$$p = \frac{1}{K_1} + \frac{1}{K_2} + (n_1 + n_2)M_t - X_t$$

$$q = \left(\frac{n_1}{K_2} + \frac{n_2}{K_1}\right)M_t - \left(\frac{1}{K_1} + \frac{1}{K_2}\right)X_t + \frac{1}{K_1 K_2}$$

**Equation 15:**

$$r = \frac{-X_t}{K_1 K_2} \quad (15)$$

Equations 14 and 15 can be solved for  $[X]$  either in closed form or (as done in Origin) numerically by using Newton's Method if parameters  $n_1$ ,  $n_2$ ,  $K_1$ , and  $K_2$  are assigned. Both  $\Theta_1$  and  $\Theta_2$  may then be obtained from equation 11 above.

As discussed earlier in section II, the heat content after any injection  $i$  is equal to

**Equation 16:**

$$Q = M_t V_o (n_1 \Theta_1 \Delta H_1 + n_2 \Theta_2 \Delta H_2) \quad (16)$$

After a similar correction for the displaced volume, the pertinent calculated heat effect for the  $i^{th}$  injection is

**Equation 17:**

$$\Delta Q(i) = Q(i) + \frac{dV_i [Q(i) + Q(i-1)]}{V_o} - Q(i-1) \quad (17)$$

which may be used in the Marquardt algorithm to obtain best values for the six fitting parameters.

---

**Sequential binding sites**

For sequential binding, the binding constants  $K_1, K_2, \dots, K_n$  must be defined relative to the progress of saturation, so that

**Equation 18:**

$$K_1 = \frac{[MX]}{[M][X]} \quad (18)$$

$$K_2 = \frac{[MX_2]}{[MX][X]}$$

$$K_3 = \frac{[MX_3]}{[MX_2][X]}$$

In the sequential model, there is no distinction as to which sites are saturated, but only as to the total number of sites that are saturated. If the sites are identical, then there is a statistical degeneracy associated with the sequential saturation since the first ligand to bind has more empty sites of the same kind to choose from than does the second ligand, etc. For identical interacting sites then, we can distinguish between the phenomenological binding constants  $K_i$  (defined by equation (18)) and the intrinsic binding constants  $K_i^\circ$  where the effect of degeneracies has been removed. The relationship between the two binding constants is given by:

**Equation 19:**

$$K_i = \frac{n-i+1}{i} K_i^\circ \quad (19)$$

All calculations given below, as well as parameters reported from curve-fitting, are in terms of  $K_i$  values but the operator may convert to  $K_i^\circ$  values, if desired, using equation (19). Since concentrations of all liganded species  $[ML_i]$  can be easily expressed in terms of the concentration of the non-liganded species,  $[M]$ , then the fraction of total macro-molecule having  $i$  bound ligands,  $F_i$ , is simply

**Equation 20:**

$$\begin{aligned}
 F_o &= \frac{1}{P} \\
 F_1 &= \frac{K_1[X]}{P} \\
 F_2 &= \frac{K_1K_2[X]^2}{P} \\
 F_n &= \frac{K_1K_2\dots K_n[X]^n}{P}
 \end{aligned}
 \tag{20}$$

where

**Equation 21:**

$$P = 1 + K_1[X] + K_1K_2[X]^2 + \dots + K_1K_2\dots K_n[X]^n
 \tag{21}$$

$$X_i = [X] + M_i \sum_{i=1}^n iF_i$$

Once  $n$  and values of fitting parameters  $K_1$  through  $K_n$  are assigned, then equations (20) - (21) may be solved for  $[X]$  by numerical methods (the Bisection method is used). After  $[X]$  is known, all  $F_i$  may be calculated from equation (20) and the heat content after the  $i^{th}$  injection is determined from

**Equation 22:**

$$Q = M_iV_o[F_1\Delta H_1 + F_2[\Delta H_1 + \Delta H_2] + \dots + F_n[\Delta H_1 + \Delta H_2 + \Delta H_3 + \dots + \Delta H_n]]
 \tag{22}$$

and, as before,

**Equation 23:**

$$\Delta Q(i) = Q(i) + \frac{dV_i Q(i) + Q(i-1)}{V_o} - Q(i-1)
 \tag{23}$$

which then leads into the Marquardt minimization routine.

---

## Enzyme/substrate/inhibitor assay

Assaying enzymes, inhibitors or substrates by calorimetric activity has the major advantage that it works well for any enzyme/substrate/inhibitor system with no prior chemical modification of any participants in the reaction. The rate  $R_t$  of the substrate decomposition reaction is directly proportional to the power output in the calorimeter cell, that is

### Equation 24:

$$R_t = \frac{P}{\Delta H V_o} \quad (24)$$

where,

Parameter	Description
$P$	power generated by the reaction
$\Delta H$	heat of decomposition of the substrate
$V_o$	cell volume

The units of  $R_t$  will be moles//sec if  $P$  is expressed in  $\mu\text{cal}/\text{sec}$ ,  $\Delta H$  in  $\mu\text{cal}$  per mole of substrate, and  $V_o$  in liters, for example.

If Michaelis-Menten kinetics are assumed then the experimental values for the rate  $R_t$  can be expressed as

### Equation 25

$$R_t = \frac{k_{cat}[E]_{tot}[S]_t}{[S]_t + K_M(1 + \frac{[I]}{K_I})} \quad (25)$$

where,

Parameter	Description
$k_{cat}$	catalytic rate constant for substrate decomposition
$K_M$	Michaelis constant
$[E]_{tot}$	total enzyme concentration
$[S]_t$	instantaneous concentration of substrate
$[I]$	concentration of competitive inhibitor

Parameter	Description
$K_I$	inhibition constant

The equation as written is valid both in the absence or presence of a  $[I]$  and  $K_I$ .

The use of equation (25) assumes no effects from product inhibition. This assumption has been discussed by Todd and Gomez (Todd, M. J. and Gomez, J. Enzyme kinetics determined using calorimetry: A general assay for enzyme activity? *Anal. Biochem.* **296**, 179-187 (2001)). and found to be quantitative in many cases. In those cases where product inhibition is significant, then equation (25) can only be used to express initial rates of reaction prior to accumulation of product.

Todd and Gomez discussed in some detail the two methods by which assays can be carried out in a titration calorimeter, and these are summarized below.

### Method 1: Single injection

Using this approach, the reaction is initiated by the injecting enzyme solution from the syringe into the sample cell containing substrate solution, or vice versa. If desired, a competitive inhibitor may also be included in one solution or the other. The reaction is allowed to go to completion in the calorimeter cell, and the power  $P$  is recorded as a function of time  $t$ .

Integration of the excess power  $P$  associated with the reaction enables  $\Delta H$  to be determined, i.e.,

### Equation 26

$$\Delta H = \frac{\int_0^{\infty} P dt}{[S]_{t=0} V^0} \quad (26)$$

where  $[S]_{t=0}$  is the starting substrate concentration. Knowing  $\Delta H$ , the substrate concentration can be determined as a function of time from the equation:

### Equation 27

$$[S]_t = [S]_{t=0} - \frac{\int_0^t P dt}{\Delta H V^0} \quad (27)$$

After obtaining the time-dependent rate from equation (24), these data can be equated to the Michaelis expression in equation (25) so that the final equation can be fit by non-linear least squares. In the absence of inhibitor,  $k_{cat}$  and  $K_M$  are used as variable parameters during iterative fitting. In the presence of inhibitor  $I$ , it is best to enter previously determined values of  $k_{cat}$  and  $K_M$  and use  $K_I$  as the only variable fitting parameter.

### Method 2: Multiple injections

In this method, multiple injections of substrate solution from the syringe are made into the reaction cell containing enzyme solution (with or without inhibitor). After each injection, a sufficient time is allowed for the instrument to equilibrate at the new power level resulting from the increased substrate concentration. Measurements are carried out quickly enough, however, so that little hydrolysis of substrate takes place relative to the total substrate contained in the cell. That is,  $[S]_t$  is calculated directly from the total added substrate assuming no significant hydrolysis.

Equations (24)-(25) are still valid for Method 2, except that  $R_t$  and  $[S]_t$  now correspond to discrete values of the rate and substrate concentration after each injection, rather than time-dependent values. To determine  $\Delta H$  from equation (26), it is necessary to carry out another single-injection experiment where hydrolysis is allowed to go to completion. Having done this, then discrete values of  $R_t$  at different  $[S]_t$  are calculated, so that equation (25) can then be fit to obtain best values of  $k_{cat}$  and  $K_M$  (in the absence of inhibitor). In the presence of a competitive inhibitor, data are also fit to equation (25) but using  $k_{cat}$  and  $K_M$  as fixed (results obtained from previous experiment with no inhibitor present) and treating  $K_I$  as the only fitting parameter.

### Dimer dissociation model

A protein molecule  $P$ , may associate at high concentrations to form a dimer. The dilution of this concentrated protein solution by injection into the calorimeter cell containing buffer can then result in some heat effects from dissociation



$$K = \frac{(P)^2}{(P_2)}$$

where,

Parameter	Description
$(P)$	concentration of monomer
$(P_2)$	concentration of dimer
$\Delta H_{disc}$	heat of dissociation of the dimer

## A Equations used for fitting ITC data

It is assumed in this model that the stoichiometry is well-defined, i.e., no aggregates with stoichiometry higher than 2 are present. By measuring heats for a series of injections it is then possible, using curve-fitting, to determine the dissociation constant  $K$ , and heat of dissociation.

The equivalent monomer concentration after the  $i^{th}$  injection,  $C_i$ , is the sum of the actual monomer concentration  $(P)_i$  plus two times the aggregate concentration  $(P_2)_i$ . Using the expression for the dimer dissociation constant to obtain  $(P)_i$  in terms of  $(P_2)_i$  leads to the equation

### Equation 28

$$C(i) = K^{\frac{1}{2}}(P_2)_i^{\frac{1}{2}} + 2(P_2)_i \quad (28)$$

A similar expression applies to the solution in the syringe of fixed concentration  $C_{syr}$

### Equation 29

$$C_{syr} = K^{\frac{1}{2}}(P_2)_{syr}^{\frac{1}{2}} + 2(P_2)_{syr} \quad (29)$$

Since  $C_{syr}$  is known and  $C_i$  can be determined from  $C_{syr}$  knowing injection volumes, then  $(P_2)_{syr}$  and  $(P_2)_i$  can be determined from equations (28)-(29) if  $K$  is assigned.

The heat released  $q_i$  when the  $i^{th}$  injection of volume  $dV_i$  is made into a fixed-volume ( $V_o$ ) cell will be

### Equation 30

$$q_i = \Delta H_{disc}(P_2)_{syr}dV_i - \Delta H_{disc}[(P_2)_i - (P_2)_{i-1}][V_o + \frac{dV_i}{2}] \quad (30)$$

The first term in equation (30) is the heat content of the aggregate contained in the injection volume prior to injection while the second term is the net heat content due to

the difference in aggregate present in the cell before and after the injection. The  $[V_o + \frac{dV_i}{2}]$  factor in the final term is an effective volume which takes into account the displacement which occurs in a total-fill cell (see *General considerations, on page 310*).

Assuming experimental parameters  $V_o$ ,  $dV_i$ , and  $C_{syr}$  are known, equations (28)-(30) are simultaneous equations, which can be solved for  $q_i$  whenever values are assigned to  $K$  and  $\Delta H_{disc}$ . Only the latter two parameters are varied during iterative fitting.



## Competitive binding model

Using conventional ITC methods, binding constants from  $10^3 \text{ M}^{-1}$  to  $10^8 \text{ M}^{-1}$  can be measured most accurately. When binding constants significantly exceed  $10^8 \text{ M}^{-1}$ , instrument sensitivity becomes challenged as concentrations are lowered to the point where quantitative measurements of the binding constant would be possible. On the other hand, binding constants substantially in excess of  $10^8 \text{ M}^{-1}$  can be measured quantitatively if such strong-binding ligands are studied in competition with a second ligand, which binds competitively but more weakly to the same binding site.

Competitive binding studies are carried out using the strong-binding ligand A as the injectant, with the solution in the cell containing the second competitive ligand B as well as the binding protein P (or other target molecule). This system has two equilibria, which are displaced with each injection, that is

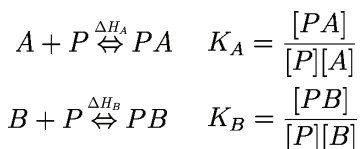

The value of  $K_B$  and  $\Delta H_B$  for the competing ligand are first measured in a conventional ITC experiment, and these parameter values are entered as known parameters when determining  $K_A$  from results of the competition experiment. For the competition experiment, the total concentration of competing ligand,  $[B]_{tot}$ , should be selected such that

$$\frac{K_A}{K_B[B]_{tot}} \cong 10^5 - 10^8 \text{ M}^{-1}$$

where " $K_A$ " is the estimated value of  $K_A$ .

The detailed equations used in the fitting model for competitive binding are found in a paper by Sigurskjold (Sigurskjold, B. W. Exact analysis of competition ligand binding by displacement isothermal titration calorimetry. *Analytical Biochemistry* **277**, 260-266 (2000)).

Sigurskjold BW.

Anal Biochem. 2000 Jan 15;277(2):260-6.

PMID: 10625516 [PubMed - indexed for MEDLINE]

Related citations

## Single injection method

### Creating new worksheet

The raw data (after time constant correction, Fourier filtering, baseline subtraction, and eliminating inappropriate data) are used to form a new worksheet, which is modeled after the existing worksheet used with multi-injection binding data.

### Input parameters

In addition to the raw data parameters ( $\Delta P$  ( $\mu\text{cal}/\text{sec}$ ) from the Y axis and time  $t$  (sec) from the X axis of the corrected raw data, the known parameters are the injection rate  $R$  (ml/sec, stored in header), total delivery volume  $V_{inj}$  ( $\mu\text{l}$ , stored in header), active cell volume  $V_{cell}$  (ml), the initial macromole concentration in the cell  $M_o$  (mM) before any dilution, the dilution factor  $dM$  for the macromolecule solution resulting from Autosampler loading, the initial ligand concentration in the syringe  $X_o$  before any dilution, the dilution factor  $dX$  for the ligand concentration resulting from loading. The approximate values are 0.95 for  $dM$  and 0.91 for  $dX$ , and the values are independent of the instrument used in the experiment.

### Point numbering

In the existing Origin worksheet for multiple injections, the rows are numbered 1,2,3, .... according to the injection number. In the worksheet for single injection experiments, the numbering corresponds to the data point number. The data points will be spaced at one for each filter period (2 s).

### DH and time $t$ columns

The DH column corresponds to the column of the same name in the existing Origin ITC worksheet while the time  $t$  column is one, which does not exist in the existing worksheet and must be added. The DH and time  $t$  columns should be filled with the data points from the above data set (after TC correction, FT smoothing, control subtraction, and data trimming). DH is the y axis value  $\Delta P$  ( $\mu\text{cal}/\text{sec}$ ) and time  $t$  (sec) is the corresponding x axis value.

### INJV column

All entries into this column should be identical and equal to the injection rate  $R$  ( $\mu\text{l}/\text{sec}$ ) times the filter time (2 s).

### $X_t$ column

$$X_t = \left( \frac{X_o d_x R t}{1000 V_{cell}} \right) \left( 1 - \frac{R t}{2000 V_{cell}} \right)$$

**M<sub>t</sub> column**

$$M_t = M^o d_M \left( \frac{1 - \frac{rt}{2000V_{cell}}}{1 + \frac{rt}{2000V_{cell}}} \right)$$

**XM<sub>t</sub> column**

$$XM_t = \frac{X_t}{M_t}$$

**Note:** Indexing for  $X_t$ ,  $M_t$ , and INJV refer to values before the  $i^{th}$  injection, while DH,  $XM_t$ , NDH refer to indexing after the  $i^{th}$  injection (the new column time  $t$  is also indexed after the  $i^{th}$  injection).

---

# Index

## A

- Abnormal peaks, 290
- Adjusting baseline, 136
- Adjusting integration range, 136
- Advanced curve fitting, 181
- Analyzing multiple runs, 143
- Associated documentation, 12

## B

- Baseline
  - adjustment, 136
  - downward stepping, 283
  - low baseline, 288
  - spikes, 286
  - upward stepping, 284
- Basic ITC data analysis, 121
- Bottle preparation
  - MicroCal iTC<sub>200</sub>, 27
- Broad peaks, 281

## C

- Chi-square ( $\chi^2$ ), 248
- Cleaning the cell, 254
- Control software
  - MicroCal iTC<sub>200</sub>, 58
  - Origin real time data, 84

## D

- Data analysis
  - adjusting baseline, 136
  - adjusting integration range, 136
  - advanced curve fitting, 181
  - analyzing multiple runs, 143
  - basic ITC data analysis, 121
  - basic ITC data fitting, 125
  - Chi-square ( $\chi^2$ ), 248
  - inserting Origin graphs into Microsoft Word, 251
  - ITC data handling, 161
  - line types for fit curves, 248
  - modifying templates, 172
  - subtracting reference, 152
  - using Origin, 118

- view mode in Origin, 249
- Documentation
  - associated, 12
  - downloadable, 12
  - user, 12
- Downloadable content, 12
- Downward stepping baseline, 283

## E

- Equations used for fitting ITC data
  - competitive binding, 321
  - dimer dissociation, 319
  - enzyme/substrate/inhibitor assay, 317
  - general considerations, 310
  - sequential binding sites, 315
  - single injection method, 322
  - single set of sites, 311
  - two sets of sites, 313

## F

- Fluid connections
  - MicroCal iTC<sub>200</sub>, 23

## H

- Hardware connections
  - MicroCal iTC<sub>200</sub>, 30
- How to get help, 297

## I

- Inserting Origin graphs into Microsoft Word, 251
- Isothermal titration calorimeter (ITC)
  - data analysis, 121
  - data fitting, 125
  - data handling, 161
  - main components, 15
  - overview, 14
- iTC<sub>200</sub> ITC methods, 306
- ITC data handling, 161

**L**

Low baseline, 288

**M**

Main components of  
ITC, 15

MicroCal iTC<sub>200</sub>, 19

Maintenance

cleaning the cell, 254

cleaning titration syringe, 268

reference cell refill, 255

replacing syringe plunger tip, 261

replacing titration syringe, 268

Methanol Hazard, 309

MicroCal iTC<sub>200</sub>

cleaning the cell, 254

cleaning titration syringe, 268

reference cell refill, 255

replacing syringe plunger tip, 261

replacing titration syringe, 268

software description, 58

software installation, 35

system description, 18

system specifications, 307

MicroCal iTC<sub>200</sub>

Bottle preparation, 27

Fluid connections, 23

Hardware connections, 30

main components, 19

set up, 22

Modifying templates, 172

**N**

Networking, 299

Installing Windows 7, 302

Installing Windows XP, 299

Windows 7, 299

Windows XP, 299

Notes and tips, 9

**O**

Origin

adjusting baseline, 136

adjusting integration

range, 136

advanced curve fitting, 181

analyzing multiple runs, 143

Chi-square ( $\chi^2$ ), 248

data analysis, 118

inserting graphs into Microsoft Word, 251

ITC data analysis, 121

ITC data fitting, 125

ITC data handling, 161

line types for fit curves, 248

modifying templates, 172

real time data display, 84

software installation, 35

subtracting reference, 152

view mode, 249

**P**

Peaks

abnormal, 290

broad, 281

reversed, 285

too large, 279

Peaks too large, 279

Performing a run

sample loading, 111

sample preparation, 88

Washing the cell and syringe, 103

Prerequisites, 8

**R**

Reagents, 309

Reference cell refill, 255

Regulatory information, 11

Replacing syringe plunger

tip, 261

Replacing the titration syringe

inserting, 272

removing, 268

Reversed peaks, 285

**S**

Setting up MicroCal iTC<sub>200</sub>, 22

Software

complete installation, 41

data analysis using Origin, 118

installation, 35

- iTC<sub>200</sub> configuration, 52
  - MicroCal iTC<sub>200</sub>, 58
  - networking, 299
  - updating, 36
  - user account settings, 54
- Spikes
- baseline, 286
  - prolonged noise spikes, 287
  - sharp spikes, 286
- Subtracting reference, 152
- System specifications
- atmospheric, 308
  - electrical, 307
  - performance, 307
  - physical, 307
  - site requirements, 308
- T**
- Troubleshooting
- abnormal peaks, 290
  - baseline spikes, 286
  - broad peaks, 281
  - downward stepping baseline, 283
  - low baseline, 288
  - peaks too large, 279
  - reversed peaks, 285
  - unexpected thermodynamic results, 292
  - upward stepping baseline, 284
- Typographical conventions, 10
- U**
- Unexpected thermodynamic results, 292
- Upward stepping baseline, 284
- User documentation, 12
- W**
- Washing the cell and syringe, 103
- Windows 7
- iTC<sub>200</sub> configuration, 52
  - networking, 299
  - network installation, 302
  - Origin 7 configuration, 50
  - user account settings, 54
- Windows XP
- networking, 299
  - network installation, 299



**Malvern Instruments Limited**

Groewood Road, Malvern  
Worcestershire, WR14 1XZ, UK

Tel +44 1684 892456

Fax +44 1684 892789

[www.malvern.com](http://www.malvern.com)

MAN0560